

This article presents an overview of design requirements of pharmaceutical pure steam generation and distribution systems with particular emphasis on recommended terminology (clean vs. pure steam) and feed water quality requirements.

## Design of Pure Steam Generation and Distribution Systems

by Hugh Hodkinson

### What is Pure Steam?

**P**ure steam is a clean utility used in the pharmaceutical industry with two primary uses:

- sterilization of product contacting components
- humidification of cleanroom and isolator air supplies

Since the above two categories are both critical to the production of pharmaceutical products, the design of pure steam generation and distribution systems is a very detailed process, which must include a wide range of considerations to ensure the steam generated is suitable for product contact and that the distribution system maintains this quality.

Pure steam has traditionally been defined as having Water For Injection (WFI) quality condensate. While this is still the case for the European Pharmacopoeia (EP), the United States Pharmacopoeia (USP) has more recently defined pure steam specifically. However, this definition of pure steam lists the quality requirements of its condensate, which actually ties in with USP WFI requirements. Furthermore, if the pure steam is to be supplied to sterilizers downstream, it should meet the quality requirements defined in European Norm (EN) 285 and Health Technical Memorandum (HTM) 2010.<sup>1, 2</sup> (Note: these are European and UK standards, but are generally used internationally.) These requirements are summarized in Table A.

The characteristics in Table A are listed because it is important that steam sterilization

takes place with saturated steam. The most effective method of heat transfer from steam is due to condensation. Therefore, the lower the dryness level, the less steam is available to condense. On the other hand, superheated steam will have to cool sufficiently prior to it condensing and non-condensable gases will never condense. All three of these are factors which reduce the efficiency of the heat transfer process.

Note that while, as stated above, pure steam is most commonly used for air humidification in pharmaceutical facilities, the ISPE Baseline<sup>®</sup> Pharmaceutical Engineering Guide on Water and Steam Systems<sup>3</sup> states “Pure steam is commonly utilized in the industry for humidification of “cleanroom” process areas due to possible exposure to the drug product. However, production areas where exposure to the drug product is of less concern commonly utilize chemical free steam for humidification.”

### Pure Steam vs. Clean Steam

There is a lot of debate throughout the industry as to which term is more appropriate: “clean steam” or “pure steam.” In many circles, both terms are acceptable and are often used interchangeably. However, it is the strong recommendation of this author to use the term pure steam for the following reasons:

- Some parties (especially equipment suppliers) use the term “pure steam” to refer to a unit that produces steam, which is suitable for pharmaceutical product contact applications (e.g., for Sterilize In Place processes), but use the term “clean steam” to refer to units which produce steam that is suitable for use in hospitals and similar environments.

This situation became problematic when a contractor ordered a Clean

*Continued on page 10.*

Reprinted from  
**PHARMACEUTICAL  
ENGINEERING**<sup>®</sup>  
The Official Magazine of ISPE  
July/August 2009,  
Vol. 29 No.4  
©Copyright ISPE 2009  
www.ISPE.org

Table A. EN 285 and HTM 2010 Steam Quality Requirements.

Characteristic	Requirement
Dryness	0.9 (0.95 for metal loads)
Superheat	< 25°C
Non Condensables	< 3.5%

High performance teams make the difference.



# Commissioning Agents, Inc.

Our teams are recognized industry leaders in developing better methods to meet your business and regulatory demands. When schedule is your problem, we are your solution.

## Major services include:

- Commissioning planning, equipment start-up, troubleshooting, field execution, verification and qualification (IQ, OQ, PQ)
- Quality Risk Management (QRM) Implementation and Risk Based Qualification Programs
- Validation – Process, Cleaning, Sterilization, Computer
- Process Improvement Services: Process Analytical Technology (PAT), technology transfer, process improvement studies
- Technical services including design reviews, SOP development, and training
- Maintenance program development and implementation
- cGMP Compliance Services – audits, regulatory reviews, improvement projects, submission assistance, and comparability protocols

**Achieve world class manufacturing.**

Call Robert E. Chew, P.E., President  
Robert.Chew@CAgents.com  
+1.317.710.1530

CommissioningAgents.com



*An Employee-Owned Company*

Steam Generator for a pharmaceutical facility, which was actually not suitable for pharmaceutical steam production and it had to subsequently be replaced.

- The ASME Bioprocessing Equipment (BPE) 2007 Guide<sup>4</sup> defines clean steam as “steam free from boiler additives that may be purified, filtered, or separated. Usually used for incidental heating in pharmaceutical applications.” The same guideline defines pure steam as “steam that is produced by a steam generator, which when condensed, meets requirements for Water For Injection (WFI).”
- Many equipment suppliers use the term “pure steam” or “pyrogen-free pure steam” exclusively throughout their documentation. If a pharmaceutical facility refers to “clean steam” throughout all of their documentation and drawings, but “pure steam” is referred to throughout all of the generation skid documentation and drawings, it creates an undesirable disparity.
- The quality of the feed water is in no way related to whether the steam produced is called “clean steam” or “pure steam” so the name used should never be based on the feed water quality.
- Although there are variations throughout the relevant guidance documents, it is common for pure steam to be defined as higher quality than clean steam or at least the same quality. Using the term “pure steam” is unlikely to cause any confusion, but the term “clean steam” is a lot more ambiguous due to different definitions throughout the industry.

## Feed Water Quality for Pure Steam Generators

This is another controversial item in the pharmaceutical industry. There is widespread debate over the quality of the feed water required by a Pure Steam Generator (PSG). The most common feed water used by PSGs is USP and EP Purified Water. The reason that purified water is normally used is because it is available in and distributed through most pharmaceutical facilities. In fact, purified water is a much higher quality than is typically required by a PSG; therefore, it is a needlessly expensive water supply if there is a lower quality supply available which still meets the PSG feed water requirements. There also are parties who advocate using Water For Injection (WFI) to feed a PSG. However, this does not make sense since the most common method of producing WFI is from a WFI Still, which operates on the same principles as a PSG. Therefore, the WFI produced is condensed steam so the feed would have been distilled twice. It should be noted that USP states that the feed water supplied to the PSG must be in accordance with feed water required for a WFI Still or Purified Water Skid. According to USP, for a WFI Still: “The minimum quality of source or feed water for the generation of Water for Injection is Drinking Water as defined by the US EPA, EU, Japan, or the WHO.” However, in practice, many PSGs require a higher standard of feed water than that.

The recommendation of this author is to contact the supplier (or potential suppliers) of the PSG to confirm the acceptable feed water quality. Then a decision must be made

Characteristic	Requirement
pH @ 2 °C	6.5 - 8.5
Conductivity @ 20°C	< 10 µS/cm
Dissolved Solids	< 5 mg/L
Chlorides	< 50 ppb
Free Chlorine	< 50 ppb
Ammonia	< 50 ppb
Total hardness	< 2 ppm
Silica as SiO <sub>2</sub>	< 1 ppm
Endotoxins	< 250 EU/ml

Table B. Recommended feed-water quality for pure steam generators.

as to which water supply in the facility would give the most cost effective feed water. To take a hypothetical example: If there was a de-ionized water loop, a Purified Water loop, and a WFI loop, where all three met the minimum feed water quality requirements, the de-ionized loop would generally be the most economic to extend to supply the PSG. Additionally, producing one liter of de-ionized water as feed is substantially less expensive than producing one liter of WFI. However, it must be stressed that before this decision can be made, the water quality must be confirmed as acceptable for the PSG.

The water quality characteristics listed in Table B can be used as a guideline for the quality of water typically required for supply to a PSG. This has been collated based on feedback from several leading PSG suppliers to the pharmaceutical industry. Note that this is purely a guideline and that the final decision for feed water quality must be made in accordance with the recommendations of the PSG supplier.

### Notes:

1. Pure steam generators will typically give a 3 to 4 log reduction in Endotoxin Level (which will be stated in the upcoming revision to ISPE Baseline<sup>®</sup> Guide: Water and Steam Systems<sup>3</sup>) which is why this is a requirement for feed water quality. One manufacturer confirmed that they achieve a minimum 3 log reduction in endotoxin levels through their PSGs.
2. Non-condensable levels in the feed water will ideally be less than 3.5% v/v, but if this requirement is not met, the PSG can be fitted with a degasser.

## Specification of a Pure Steam Generator

The key activities of a Pure Steam Generator are to evaporate the feed water, remove non-condensable gases from the system, and remove entrained droplets from the steam, while keeping the steam saturated. Removal of non-condensable gases is necessary because there is a non-condensables limit specified in HTM 2010. Removal of entrained droplets is necessary because dryness is another key quality criterion, but also because these droplets will carry over contamination from the feed water. Saturation is important for effective steam sterilization because most of the energy transferred is from latent heat of condensation.

*Continued on page 12.*



# ELETTACQUA

*pure water technologies*

SINCE 1966

## PHARMACEUTICAL WATER SYSTEMS



MULTIPLE EFFECTS DISTILLATION UNIT

DESIGN AND CONSTRUCTION OF PURIFIED WATER PACKAGES ◊ DOUBLE PASS REVERSE OSMOSIS ◊ R.O. + ELECTRODEIONIZATION HOT WATER SANITIZABLE ◊ ULTRAFILTRATION ◊ MULTIPLE - EFFECT DISTILLATION UNITS ◊ PURE STEAM GENERATORS ◊ STORAGE AND DISTRIBUTION LOOP ◊ COMPLETE TURN KEY PROJECTS ◊ VALIDATIONS IQ, OQ

[www.elettracqua.com](http://www.elettracqua.com)



Common methods of reducing entrained droplets include using demister plates in the main evaporator, designing the evaporator column to be long and wide enough that the steam upflow is low enough that droplets fall back into the boiling feed water, and/or using a cyclone effect so that centrifugal force drives entrained droplets against the evaporator wall (baffles can be used to augment this process).

It is good practice to degas the pure steam produced. If there is a feed water tank on the skid, it is common to heat the feed water and recirculate it so that it sprays back into the feed water tank, enabling non-condensable gases to be released through a stack vent on the tank. If there is no feed water tank, some suppliers can feed a degassing vent directly to the evaporator column. These can operate by means of a falling film on the infeed line to the PSG, where the hot feed water releases non-condensable gases which rise up through a degassing vent. The advantage of fitting this directly to the evaporator is a smaller overall footprint for the PSG, but the vent stack is generally more difficult to remove than from the feed water tank.

Prior to ordering a PSG, it is wise to meet with one or more leading PSG suppliers to discuss the details and exact requirements of your application. Some key items that should be considered for the PSG specification are summarized below. Note that the below list is aimed at design items which are specific to PSGs and is not intended to be an all encompassing list covering items common to specifying any piece of sanitary equipment, such as documentation requirements, testing requirements, safety requirements, construction requirements, etc. Key items to consider when specifying a PSG are:

- The quality of the feed water proposed for the PSG.
- Ensure the PSG outlet is fitted with EN 285/HTM 2010 test points, as well as a test point for taking pure steam condensate samples. If the pure steam does not meet these quality requirements at the facility user points, the first check that should be performed is that the PSG is producing sufficiently high quality steam.
- Ensure the PSG is fitted with a degasser. This gives confidence that non-condensable requirements will be met in the system.
- State the feed water minimum supply pressure. PSGs require a feed water tank and booster pump if the feed water pressure is not a sufficient quantity greater than the pure steam generation pressure – commonly 1 bar (14.5 psi), but this varies between suppliers.
- It is recommended that inlet feed water is used to condense pure steam for inline conductivity monitoring and offline analysis. Otherwise, a separate cooling water supply is required to the PSG skid.
- Effluent from the PSG is going to be hot, and if it is not cooled, a plume of steam will be generated at the waste connection from the skid. So it is recommended to include a blow down vessel in the skid where the effluent is cooled by process water or similar. Also note that the vent from this blow down vessel will typically be exhausting hot water vapor so it is normal to pipe this vent outside the building.
- The flowrate and pressure required at the PSG outlet (based on the requirements of the distribution system users).
- Passivated 316L stainless steel is the recommended material of construction as pure steam is a very corrosive substance. Non-metallic piping materials of PVDF and PTFE could be used if rated for the pressure and temperature. Schedule 80 would be preferable.
- A surface finish of  $Ra < 0.5 \mu\text{m}$  (20 microinch) is recommended for pure steam contacting parts.
- Hygienic connections to be used throughout. High pressure clamps which require a tool to remove are recommended over clamps which can be removed merely by hand.
- Any interaction with the upstream feed water distribution system should be specified, such as feed water request signals sent from the PSG control system and feed water available signals returned to the PSG control system.
- A small stream should be taken off the pure steam outlet, condensed and monitored continuously for conductivity. Note that the ISPE Baseline® Guide<sup>3</sup> states that temperature compensated conductivity sensors cannot be used for critical quality assurance testing of purified water, highly purified water, WFI, and pure steam condensate.
- It is common to record the PSG pure steam condensate conductivity and temperature for a facility's batch records. Since most PSGs are Programmable Logic Controller (PLC) based and do not have permanent data storage, it is recommended that this data is stored either by connecting the PLC to a Supervisory Control and Data Acquisition (SCADA) system or alternatively that the conductivity and temperature signals are routed in parallel to a data logging system. In the case of the latter, it is recommended that a signal is also sent from the PSG PLC to confirm that good quality steam is being produced. Otherwise, it will not be clear from the data logged when the PSG is running properly and when it is in alarm or shut down.
- One item that must be considered when designing a pure steam system is whether and how the feed water system is sanitized. If the feed water is normally cold, but is sanitized by heating the feed water distribution, this can generally be catered for in the PSG design if the vendor is informed up front. However, if a different method of feed water sanitization is used (e.g., chemical sanitization), then it could be necessary to stop feeding the PSG for the duration of sanitization. If there is no feed to the PSG for a sufficient period, it will have to shut down. This would obviously have a drastic effect if the facility air handling units depend on the PSG for pure steam. Note that feed water sanitization depends on the design of the feed water system and is not a requirement of the PSG.
- It is typical for the pure steam distribution system header to be a purely mechanical system. That is, the distribution does not have its own control system. The key parameter that must be controlled in the distribution header is the pressure, which is set in the PSG control system.
- The most common temperature used for sterilization processes is 121°C. 134°C is used for some processes, but this is much less common. These temperatures correspond to steam supply pressures of ~1.1 barg (16.0 psig) and ~2.0 barg (29.0 psig)

*Continued on page 14.*



# In safe hands

Containment Solutions for the Pharmaceutical & Biotech Industries

- Barrier Isolation Systems
- Downflow Containment Booths
- High Containment Screens
- Pack Off and Process Equipment
- Kilo Labs & Glassware Enclosures



For further information please contact us on

North America

502 968 2065

Rest of the World

+44 (0) 1204 571131

[info@howorthgroup.com](mailto:info@howorthgroup.com)

[www.howorthgroup.com](http://www.howorthgroup.com)

respectively. To allow for pressure losses in the distribution system and to buffer the distribution system, it is common to run distribution headers at pressures in the range of 2.5 – 3.0 barg (36.3 psig – 43.5 psig). However, it is important to check the pressure required by each of the downstream users before deciding on the pressure required in the header and corresponding pressure setpoint at the PSG outlet.

## Design of a Pure Steam Distribution System

The design of a pure steam distribution system is more complex than might first appear. The following design guidelines assume that the pure steam generator has been correctly specified and will produce pure steam of a quality that meets USP and EN 285 requirements (as well as meeting EP WFI quality limits for Pure Steam condensate).

Once the PSG has been correctly specified, designed, and installed, it is critical that the distribution system delivers pure steam of a sufficient quality to the facility user points. A poorly designed distribution system can reduce the quality of the steam so that it does not meet the regulations pertaining to pure steam.

### Header Design

Headers must be designed so that they minimize condensate formation and any condensate which is formed is routed out of the distribution system, maintaining a dry steam supply to each user point. To this end, the following design features are recommended:

- Piping runs slope to at least 1%
- Steam traps are recommended:
  - at the end of each header or branch
  - every 30m (~100 ft) on any straight run
  - at each user point or sample cooler
  - where the line transitions from horizontal to vertical (at the bottom of the vertical riser)
  - at thermal expansion loops
  - anywhere condensate could build up and would not otherwise be removed (i.e., there should be no dead legs where condensate can build up)
- Thermostatic steam traps to be used throughout. These are the most common sanitary traps for pure steam distribution systems and have the ability to remove air from the system. Float traps and thermodynamic traps are not free draining and do not release air from the system so they are not recommended.
- Never group steam traps. This means that multiple users are not run to a single trap (this often leads to preferential draining for one piece of equipment, because different pieces of equipment will release condensate at different temperatures and pressures). It also means that the discharge lines from traps must not be connected. Each of these should go to drain through a separate air gap since linking these lines can hinder the release of condensate through one or more of the traps.
- Trap legs for the collection of condensate from the steam distribution system should be of equal size to the distribu-

tion line for sizes up to 4 inch (100 mm) and one or two sizes smaller for lines of 6 inch (150 mm) or larger.

- 30 cm (~1 ft) of uninsulated piping above each steam trap. Thermostatic traps release condensate which is a few degrees colder than the steam saturation temperature would be at the operating pressure. Therefore, the condensate must be allowed to cool so that it is released through the trap.
- Full bore ball valves used throughout, but diaphragm valves are advisable at the sterile boundary of an aseptic system, e.g., the last valve on a line for SIP of a vessel would be a diaphragm valve, but the preceding valves would be ball valves. Diaphragm valves used in a pure steam system require far more maintenance than ball valves.
- Sanitary pressure regulators are to be used where required. Sanitary pressure regulators typically have a bottom mounted inlet and side mounted outlet so that any condensate built up in the regulator flows back through the regulator inlet.
- No direct connections to unhygienic systems. Air gaps to be used at all drain points.
- Hygienic connections used throughout. High pressure clamps which require a tool to remove are recommended over clamps which can be removed merely by hand.
- Passivated 316L is the recommended material of construction as pure steam is low in ions and is a very corrosive substance.
- User point take offs are piped off the top of headers to minimize entrained condensate.
- Headers and take offs are typically sized to give a steam velocity in the range of 20 to 30 m/s (~65 to 100 ft/s) to minimize entrained condensate in the pure steam flows. Note lower velocities also are acceptable.
- Sample points to be easily accessible.
- It is often stated that pure steam distribution systems are self sterilizing and the benefits of polished tubing is questioned. However, it is very common throughout the industry (and recommended by this author) to polish distribution systems to finishes of  $R_a < 0.5 \mu\text{m}$  (20 microinch) or less (depending on the site standard) and is recommended. Sometimes for smaller components such as steam traps, this requirement cannot be met and can be relaxed to  $R_a < 0.8 \mu\text{m}$  (32 microinch).
- Air breaks to be at least twice the size of the relevant pipe diameter.
- Eccentric reducers used for any horizontal reductions in pipe diameter.

A typical autoclave user point is shown in Figure 1. Note that this includes HTM 2010 test points and a pressure gauge as well as local condensate sampling. Not all of these features are required at every user point, as described in the sampling section below. Also note that 50 mm (2") air breaks are used in this example. This is a common length, but air breaks should always be at least twice the pipe diameter used in the given application.

### Sampling

It is recommended to take samples to prove compliance with the following:

*Continued on page 16.*

# Intelligen Suite

The Market-Leading Engineering Suite for Modeling, Evaluation, Scheduling, and Debottlenecking of Single & Multi-Product Facilities

## SuperPro

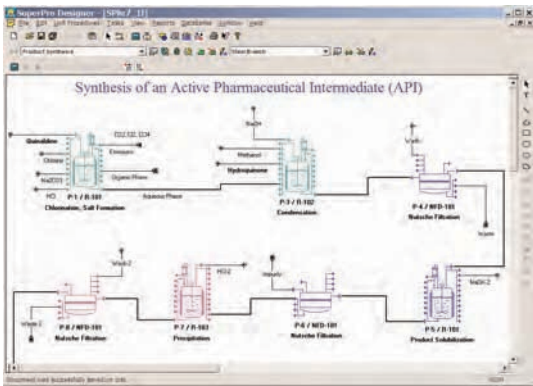

## SchedulePro

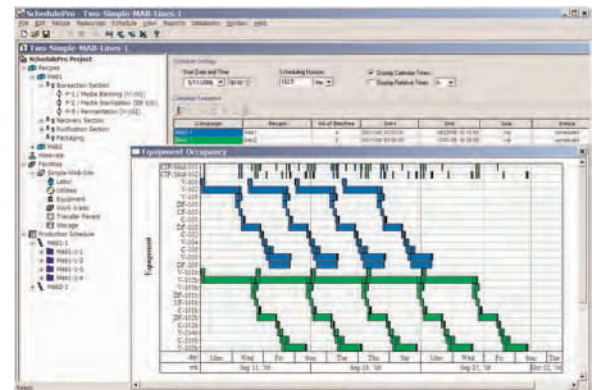

Use SuperPro Designer to model, evaluate, and debottleneck batch and continuous processes

Switch to SchedulePro to schedule, model, and debottleneck multi-product facilities



Tracking of equipment occupancy in multi-product facilities

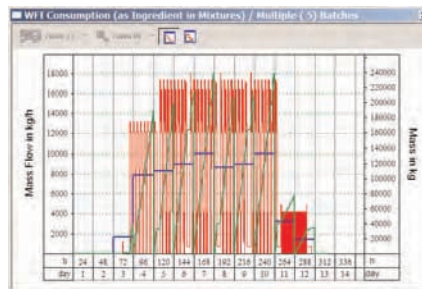

Tracking demand for resources (e.g., labor, materials, utilities, etc.)

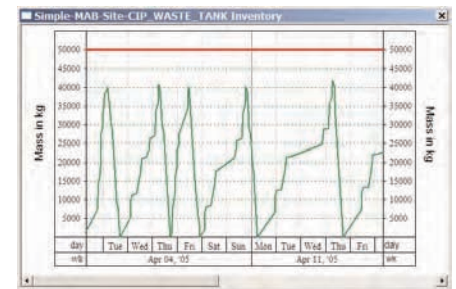

Inventory tracking for raw materials, intermediates, products, and wastes

**SuperPro Designer** is a comprehensive process simulator that facilitates modeling, cost analysis, debottlenecking, cycle time reduction, and environmental impact assessment of biochemical, specialty chemical, pharmaceutical (bulk & fine), food, consumer product, mineral processing, water purification, wastewater treatment, and related processes. Its development was initiated at the Massachusetts Institute of Technology (MIT). SuperPro is already in use at more than 400 companies and 500 universities around the world (including 18 of the top 20 pharmaceutical companies and 9 of the top 10 biopharmaceutical companies).

**SchedulePro** is a versatile finite capacity scheduling tool that generates feasible production schedules for multi-product facilities that do not violate constraints related to the limited availability of facilities, equipment, resources and work areas. It can be used in conjunction with SuperPro (by importing its recipes) or independently (by creating recipes directly in SchedulePro). Any industry that manufactures multiple products by sharing production lines and resources can benefit from the use of SchedulePro. Engineering companies use it as a modeling tool to size utilities for batch plants, identify equipment requirements, reduce cycle times, and debottleneck facilities.

**Visit our website to download detailed product literature and functional evaluation versions of our tools**

**INTELLIGEN, INC. • 2326 Morse Avenue • Scotch Plains, NJ 07076 • USA**

**Tel: (908) 654-0088 • Fax: (908) 654-3866**

**Email: [info@intelligen.com](mailto:info@intelligen.com) • Website: [www.intelligen.com](http://www.intelligen.com)**

**Intelligen also has offices in Europe and representatives in countries around the world**



# Pure Steam Generation

- a. Pure steam condensate complies with USP and/or EP (as relevant)
- b. Pure steam quality complies with HTM 2010/EN 285 dryness, superheat, and non-condensable requirements as described in the introduction to this article

With respect to a. above: Sample coolers are recommended at the following locations:

- At the end of each header
- At each critical user take off, i.e., where pure steam is used on product contacting surfaces such as for equipment SIP or for autoclaves. However, for non-product contacting users such as steam used for humidification,

it is generally acceptable to sample at the end of the relevant header.

It is advisable to fit a hygienic needle valve immediately upstream of the sample cooler so as to control the sample flowrate. It also is recommended to normally fit a steam trap at the outlet of the sample cooler so that it is continuously self sterilizing, but to have a spool piece which can be used to replace the steam trap during sampling (obviously after the system has been isolated and allowed to depressurize and cool sufficiently).

With respect to b. above: HTM 2010/EN 285 test points are recommended at the following locations, at a minimum:

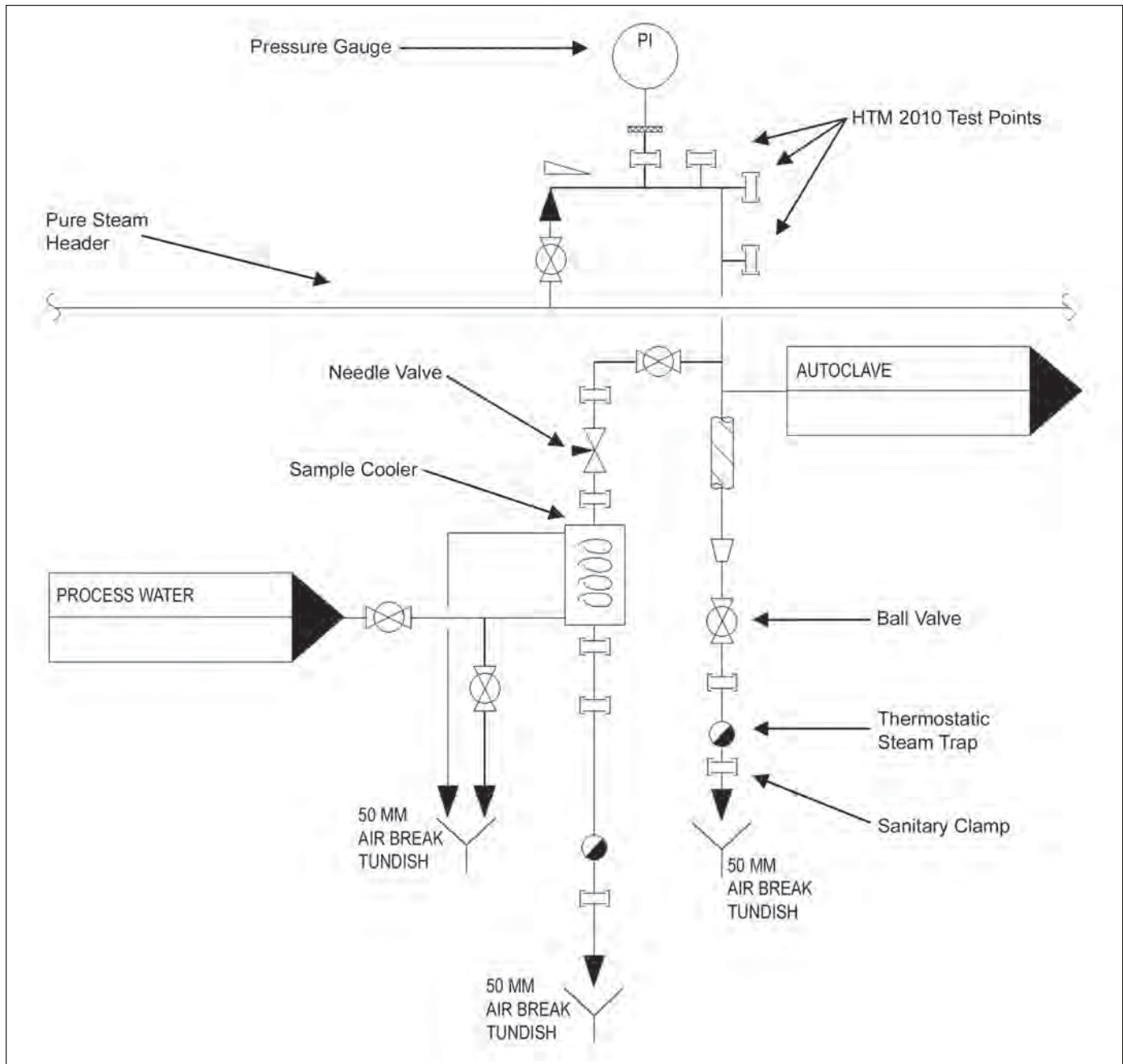
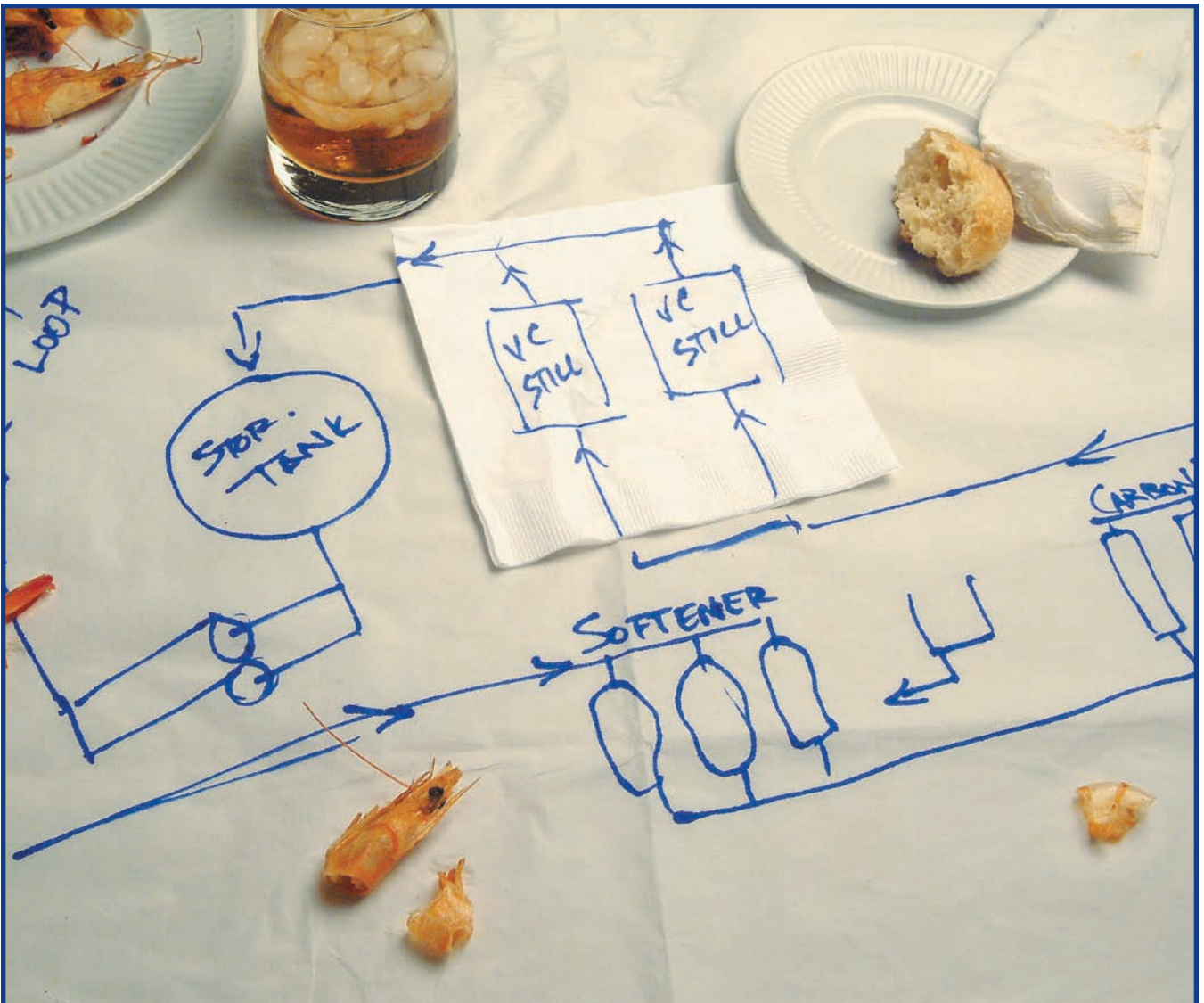

Figure 1. Typical pure steam supply configuration for an autoclave.

*Concludes on page 18.*



**VAPOR COMPRESSION IS JUST THE BEGINNING OF WHAT WE DO.**

**Innovative Solutions For Purified And WFI-Grade Water And Pure Steam.**

It was a big idea that simply got bigger. Today, MECO has grown to provide expert guidance and customized solutions for every phase of water and Pure Steam generation. Whether you need a particular product, a specialized service or an entire water plant designed and built from scratch, MECO delivers. To see for yourself, visit [mecobiopharm.com](http://mecobiopharm.com) or call 1-800-421-1798.

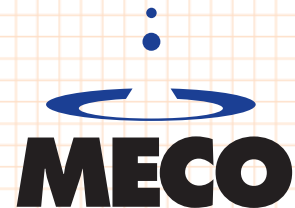

PEOPLE

PRODUCTS

SERVICE

US \_ UK \_ Singapore \_ UAE \_ 800-421-1798 \_ [mecobiopharm.com](http://mecobiopharm.com)  
12505 Reed Road, Suite 100, Sugar Land, TX 77478

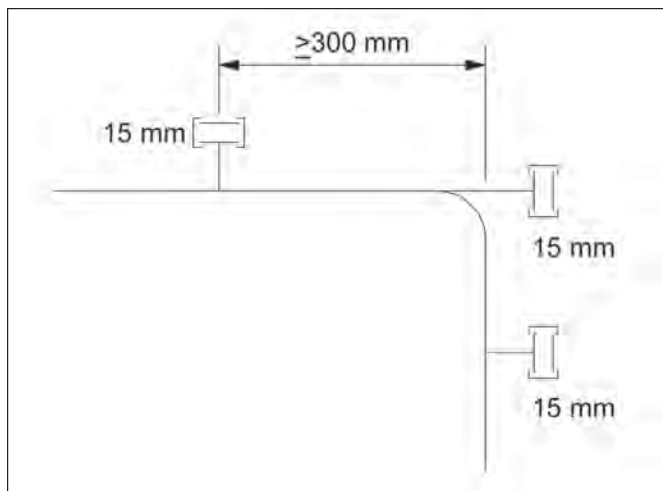

Figure 2. Typical HTM 2010 sampling arrangement.

- At each autoclave (as stipulated in the above standards)
- At each lyophilizer (not specified in the above standards, but good practice)
- At the PSG outlet. Normally, in the scope of the PSG supplier.

Three ½" hygienic clamp connections are required for these sample points. It is recommended to have an isolation valve immediately upstream and a pressure gauge to confirm that the line has been depressurized before clamp blind caps are removed to connect sampling equipment. It cannot be stressed enough that these sample points must be accessible. They are often installed as an afterthought and can then be extremely difficult to connect with the relevant sampling equipment. During the initial piping layout design, it must be anticipated to locate these sample points as close to the autoclave (or other equipment) as possible, but certainly within 2 or 3 meters.

These HTM 2010/EN 285 test points are used to take samples manually. Non-condensables are measured by condensing a quantity of steam and then measuring the volume of this which is water and the volume which is gas. Superheat is measured by routing steam through an expansion tube and checking that there is not an excessive temperature difference between that temperature and the main header temperature. Dryness is measured by condensing steam from the header. A typical HTM 2010 test connection is shown in Figure 2.

Note that the dryness HTM 2010 test in particular is very sensitive to entrained moisture, and if there are flaws in the design or installation of the pure steam distribution system, this is the test that is most likely to fail. Even if an upstream pipe has been stepped on during construction and bent (even if it is almost imperceptible to the naked eye) so that there is slight pooling of condensate in the line, this amount of condensate can be enough to make the system fail its dryness test.

## Air Venting

There are sources which recommend installing a high point trap for venting air out of the pure steam system. However,

this is not recommended for a continuously running pure steam system. While it is possible that a high point trap, such as this, will accelerate the de-aeration of the system, this is not a worthwhile gain for a system which will only be shut down and started up once or twice a year. It must be noted that once hot, air is heavier than steam and that thermostatic traps operate based on temperature. In other words, the low point steam traps will pass air until the system is de-aerated. These types of high point air vents can make sense in plant steam systems which use thermodynamic or float traps which are based on velocity and density respectively (i.e., will not pass air), but do not make sense for a distribution system which uses thermostatic traps throughout.

Furthermore, the ideal location of the high point venting trap is frequently in a very inaccessible location at the top of the building, often at the top of a pipe rack. Over time, these traps can begin to leak. If the trap begins to leak, it will have to be removed for maintenance. Since these are generally difficult to access, they are often permanently removed after they have leaked a few times.

## Conclusion

The above article is intended as a guideline to some of the key issues to consider when designing a pure steam generation and distribution system. In particular, it aims to discuss many of the contentious issues which come up repeatedly in the design of pure steam systems. However, it is recommended to seek the advice of a professional designer when designing or modifying such systems.

## References

1. EN 285:2006 Sterilization. Steam Sterilizers. Large Sterilizers.
2. Health Technical Memorandum (HTM) 2010 Crown Copyright 1994.
3. ISPE Baseline® *Pharmaceutical Engineering Guide, Volume 4 - Water and Steam Systems*, International Society for Pharmaceutical Engineering (ISPE), First Edition, January 2001, <http://www.ispe.org>.
4. ASME BPE 2007 Bioprocessing Equipment.
5. United States Pharmacopoeia 32-NF27, 1 November 2009.

## About the Author



**Hugh Hodkinson** is a Lead Process Engineer for DPS Engineering. Educated at University College Dublin, he holds a BE in chemical engineering. He has been with the company since 1999 and has led aseptic design projects in Ireland, the UK, and the Netherlands. His experience includes a variety of facilities for vaccine production, cell culture production,

downstream processing, and fill finish products. He can be contacted by telephone: +353-86-8185589 or by email: [hugh.hodkinson@dpseng.com](mailto:hugh.hodkinson@dpseng.com).

DPS Engineering, Landscape House, Baldonnell Business Park, Baldonnell, Co. Dublin, Republic of Ireland. 

# New ISPE Online Learning Programs



## Three new categories

of programs are now available as part of ISPE's expanding Online Learning library. Available for download anytime, these programs provide cost-effective learning solutions, especially for professionals experiencing travel and budget restrictions.

### 2009 Washington Conference Series

---

Video recordings of ISPE education sessions are available for those who missed an event, or those who want to experience it again. The 2009 Washington Conference Series features topics such as global supply chain integrity, validation and quality by design, and discussions with numerous global regulators — including those from the U.S. Food and Drug Administration.

### **Certified Pharmaceutical Industry Professional™ (CPIP™) Online Courses**

---

Self-directed courses providing a broad range of learning opportunities for career growth and professional development. They target two groups: those interested in general pharmaceutical industry knowledge on topics ranging from drug product development to manufacturing, and those seeking industry-wide recognition for accumulated experience by obtaining the CPIP credential.

### **Good Manufacturing Practice (GMP) Online Courses**

---

A series of interactive pre-recorded courses reviewing the pre-approval and post-approval USFDA GMP inspection approach for quality, facilities/equipment, laboratory, materials, packaging/labeling, and production systems.

Visit [www.ISPE.org/onlinelearning](http://www.ISPE.org/onlinelearning) to learn more, and to download and search the new ISPE Online Learning Catalog.



This article presents the advantages and disadvantages of distillation-based and membrane-based methods for producing WFI, outlines international WFI regulatory requirements, discusses historical market penetration and performance of distillation and membrane-based WFI systems, and includes a membrane case study.

## Methods of Producing Water for Injection

by Henry Brush and Gary Zoccolante

### Introduction

**W**ater For Injection (WFI) international pharmacopoeial standards have been brought closer through harmonization efforts, but significant differences still exist. The USP WFI monograph allows production by “distillation or a purification process proven to be equal to or superior to distillation.” USP language is the least restrictive in terms of acceptable processes among the major pharmacopoeial groups. The Japanese Pharmacopoeia (JP) allows distillation or Reverse Osmosis (RO) followed by UltraFiltration (UF). Distillation is the only WFI method of production that is approved by the European Pharmacopoeia (EP).

Historically, distillation has been the preferred method for producing WFI in the biopharmaceutical industry, and today, most pharmaceutical WFI is produced by distillation. Regulatory requirements have helped significantly in the domination of WFI production by distillation, but distillation also has

been successful in attainment of the water quality specifications. Yet, most other high-purity industries use reverse osmosis, deionization, and ultrafiltration, not distillation, to produce WFI equivalent or higher quality water. ASTM Type A laboratory water limits for total bacterial count and endotoxin are respectively ten and eight times lower than WFI. ASTM Type 1.2 water for microelectronics has similar microbial restrictions with total organic carbon and conductivity limits well below WFI. Those applications are routinely satisfied with membrane-based systems producing water at ambient temperature. However, those industries do not have regulated process limitations.

This article will discuss the advantages and disadvantages of distillation-based and membrane-based methods for producing WFI; outline international WFI regulatory requirements; and discuss historical market penetration and performance of distillation and membrane-based WFI systems. Also included is a membrane case history from US biopharmaceutical company Alkermes, Inc.

Table A. WFI Requirements for USP, EP, JP.

	USP	EP	JP
Method of WFI Production	Distillation or purification process proven to be equal to or superior to distillation	Distillation only	Distillation or RO/UF
Conductivity, $\mu\text{S}/\text{cm}$ @ 25 °C or equiv. @ other temps.	1.3	1.3	1.3
TOC, ppb	< 500	< 500	< 500
Endotoxin	0.25 EU/mL	0.25 EU/mL	0.25 IU/mL
Bacteria, cfu/100 mL	10	10	10
Nitrates, ppm	N/A	0.2	N/A
Ammonium, mg/L	N/A	N/A	0.05

### Distillation-Based WFI Systems

To meet USP requirements, WFI must be produced by “distillation or a purification process proven to be equal to or superior to distillation.” Additionally, the water must pass conductivity and Total Organic Carbon (TOC) tests, and the bacteria endotoxin level must be below 0.25 endotoxin units per milliliter (EU/mL). The microbial level must not be above 10 Colony-Forming Units (CFU) per 100 mL. Distillation is effective at quantitative reduction of most water contaminants and can produce water with low conductivity,

*Continued on page 22.*

Reprinted from  
**PHARMACEUTICAL  
 ENGINEERING®**  
 The Official Magazine of ISPE  
 July/August 2009,  
 Vol. 29 No. 4  
 ©Copyright ISPE 2009  
 www.ISPE.org

A photograph of an iceberg floating in the ocean. The tip of the iceberg is visible above the water surface, while the vast majority of the iceberg is submerged below the surface, illustrating the concept of 'the tip of the iceberg'. The water is a deep blue, and the sky is a clear, light blue.

# How can I find real depth in cost-effective water solutions?

## With Siemens, cost-effective solutions are just the tip of the iceberg.

Siemens Water Technologies provides the largest portfolio of innovative solutions that get below the surface of all your plant's needs. Our reduction, reclaim and reuse approach helps your plant's water and energy conservation efforts, drastically reducing costs and waste production while meeting ever-increasing regulations. And with the most validated and non-validated pharmaceutical installations around the globe, experienced service teams, and fully functional factory acceptance tests (FAT), product safety and reliability are ensured, and profitability is maximized. Count on Siemens to provide more than just the tip of the iceberg. For more information, call 800.875.7873 ext. 5000 or visit [www.siemens.com/iceberg](http://www.siemens.com/iceberg)

Answers for industry.

**SIEMENS**

low TOC, low microbial levels, and low endotoxin levels.

Almost all pharmaceutical distillation-based systems implement either multiple effect or vapor compression stills. Both still types employ various techniques for recovery of latent and sensible heat to minimize energy consumption. Both technologies produce WFI quality water when properly implemented and operated. Each still type has advantages and disadvantages and each has significant successful operational history.

While stills are reliable, they are not perfect, and can produce pyrogenic product water when operated incorrectly, when they fail mechanically or when the feed water contains contaminant levels beyond the still reduction capability. If fed with high endotoxin feed water from the raw supply or pretreatment equipment, in cases where there is no membrane-based system pre-treating the still, the product water from the still may fail the endotoxin test. Many successful distillation systems exist with no membrane pretreatment, but several other systems have required retrofit of Reverse Osmosis (RO) or UltraFiltration (UF) pretreatment after periodic product water endotoxin failures due to high still feed endotoxin levels.

The FDA Guide for Inspections of High-Purity Water Systems recognizes the still pretreatment design question regarding potential use of a membrane process. Section V of the Guide states, "Many of the still fabricators will only guarantee a 2.5-log to 3-log reduction in the endotoxin content. Therefore, it is not surprising that in systems where the feed water occasionally spikes to 250 EU/mL, unacceptable levels of endotoxins may occasionally appear in the distillate (WFI). For example, three new stills, including two multi-effect, were recently found to be periodically yielding WFI with levels greater than 0.25 EU/mL."

The FDA Guide further states, "Pre-treatment systems for the stills included only deionization systems with no RO, ultrafiltration, or distillation. Unless a firm has a satisfactory pre-treatment system, it would be extremely difficult for them to demonstrate that the system is validated."

The decision to implement or not implement reverse osmosis in still pretreatment is generally more relevant to vapor compression stills than multiple effect stills. Vapor compression stills operate at a lower temperature than Multiple-Effect (ME) stills and are less susceptible to chloride stress corrosion and scale; therefore, reverse osmosis is not always necessary for scale and corrosion prevention. Multiple effect stills generally require feed water with low levels of chloride, silica, and total solids, and are almost always pretreated with reverse osmosis and/or an ion exchange process. Since reverse osmosis is present in almost all ME still feed systems, the feed endotoxin levels are quite low.

## **Vapor Compression Distillation**

Vapor compression distillation systems generally implement scale control, dechlorination, and in some cases, reduction of ionized solids and/or endotoxin. A vapor compression distillation system often consists of softening, heat exchanger, hot-water-sanitizable activated carbon, prefilter, optional hot-

water-sanitizable RO, and finally, a vapor compression still. The key design consideration is inclusion or exclusion of RO.

RO is excluded when ionized solids and endotoxin reduction is not deemed necessary for reliable, consistent attainment of WFI quality parameters. RO is implemented when the user believes that reduction of endotoxin and ionized solids in the still feed assures that WFI quality is consistently attained, maintenance is minimized, and hot blowdown is minimized. Many systems of both types are in operation. If only endotoxin reduction is desired in the still pretreatment system, UF may be substituted for RO.

In addition to meeting all pharmacopoeial requirements, vapor compression distillation offers the following advantages:

- generally reliable operation
- typically more energy efficient than multiple-effect distillation
- can be operated on softened/dechlorinated feed
- may not require a complex system design
- relatively low maintenance

Potential disadvantages of vapor compression stills include:

- may be more labor intensive than multiple-effect distillation with compressor and associated drive gear
- may have higher life cycle cost than membrane based systems

## **Multiple-Effect Distillation**

A Multiple-Effect Distillation (MED) system often consists of a multi-media filter, softening, break tank, heat exchanger, hot-water-sanitizable activated carbon, prefilter, optional pH adjustment, 254-nanometer ultraviolet (UV) light, hot-water-sanitizable RO, continuous electrodeionization (CEDI), followed by the multiple-effect distillation unit. The pretreatment system is generally comprehensive because the high operating temperature makes MED stills susceptible to chloride stress corrosion and scale. The pretreatment system typically minimizes chloride, silica, and total dissolved solids levels. Membrane based pretreatment typically reduces endotoxin to very low levels, such that the still endotoxin challenge is negligible.

- In addition to meeting all pharmacopoeial requirements, multi-effect distillation has the advantage of few moving parts and this can minimize maintenance requirements.

Potential disadvantages include:

- generally requires high-quality feed water: less than 0.5 ppm chloride; less than 1.0 ppm silica; less than 5.0 µS/cm conductivity
- typically higher energy costs than vapor compression distillation
- typically higher cooling water requirements than vapor compression

*“Most alternative designs to distillation have used one or two passes of RO, often with an ion exchange process and in virtually all cases, final polishing with UF or RO. The system designs over decades have been driven by practicality and regulation.”*

- may have higher life cycle costs than membrane-based system

### What Other Treatment Methods Work?

A number of separation methods, such as RO and UF, can remove endotoxin. Oxidation with ozone also removes endotoxin. Heat, distillation, UF, RO, filtration, ozone, UV, and chemical methods can all achieve low microbial levels in the product water. Other market applications, such as microelectronics and select laboratory water types have water quality specifications far tighter than WFI including extremely low endotoxin limits. Almost all of these systems utilize membrane technologies for primary treatment. Membrane systems may offer lower operating economics as no water evaporation occurs. Systems either operate at ambient temperature normally or are heated to high temperature without evaporation and condensation. The content of stainless steel is often less with membrane systems compared to distillation.

### Membrane-Based WFI Systems

Most alternative designs to distillation have used one or two passes of RO, often with an ion exchange process and in virtually all cases, final polishing with UF or RO. The system designs over decades have been driven by practicality and regulation. The first alternative to distillation allowed by USP decades ago was RO. RO technology was generally not up to the task of consistent WFI performance and the technology did not flourish. Hot water sanitizable membranes did not exist and chemical sanitization was often inconsistent, allowing periodic microbial excursions beyond WFI specification. Some validated systems existed, but placements were few.

The presence of membrane systems was enhanced when the Japanese Pharmacopoeia allowed RO followed by UF as an alternative to distillation. Hot water sanitizable and continuous hot ultrafiltration elements were available and contributed to successful operation. Ultrafiltration had a lengthy, successful history in pharmaceutical manufacturing and was accepted. This technology change led to implementation of more systems that produced “WFI quality” water where pharmacopoeial WFI compliance was not required.

The change by USP to open WFI production to “distillation or a purification process proven to be equal to or superior to distillation” has helped to increase interest in membrane based WFI systems.

EP has created a monograph for Highly Purified Water with no process limitations and water quality specifications identical to WFI. This has helped to increase membrane system placement for production of “WFI quality” water.

Two-Pass RO (TPRO), also known as product staged RO, was one of the earliest WFI membrane configurations. TPRO

systems were more popular prior to the presence of conductivity and TOC tests. At that time, the USP WFI monograph only allowed distillation or RO for process and it was accepted that the still or RO would be the terminal process. The FDA had noted in “The FDA Guide for Inspections of High-Purity Water Systems” that if RO was used for WFI, two stages should be used to assure attainment of the quality specifications. TPRO can typically meet all of the required water quality parameters, but consistent attainment of Stage 1 conductivity can be an issue with some feed waters. TPRO systems often consist of a multi-media filter, softening, break tank, heat exchanger, hot-water-sanitizable activated carbon, prefilter, optional pH adjustment, 254-nm UV, and two stages of hot-water-sanitizable reverse osmosis.

The implementation of a WFI conductivity test requirement and the liberalization of the USP WFI allowable processes increased use of systems implementing reverse osmosis, ion exchange processes, and ultrafiltration or a final stage of RO. The logic of this type of system configuration is that the combination of reverse osmosis and ion exchange easily meet the conductivity and TOC specifications while the final ultrafilter or RO stage assures compliance with the endotoxin and microbial requirements. Systems of this type have had a lengthy history in production of “WFI quality water” prior to acceptance as a method to produce WFI to pharmacopoeial standards. The basic system capability for production of water with low contaminant levels has been long proven in other markets, such as microelectronics, for decades.

Most membrane based systems have several components that are either intermittently hot water sanitized or maintained continuously at a self sanitizing high temperature. Some systems have a final membrane stage that operates at the same elevated temperature as the storage and distribution system. Several systems of this type have been in operation for more than 10 years with water quality performance equivalent to distillation based systems.

A typical membrane based WFI system includes dechlorination, softening, a hot-water-sanitizable RO device followed by a hot water sanitized CEDI device. A continuous hot-water UF device polishes the water prior to storage and use as WFI if the water will be stored hot. A hot water sanitized UF or RO serves as the final stage if the product water will be stored at ambient temperature. Advantages of using RO/RO or RO/UF to produce WFI are as follows:

- may be the lowest life cycle cost alternative
- typically low energy requirements
- typically very low conductivity, TOC, endotoxin, and microbial levels
- generally reliable operation

*Continued on page 24.*



- can be intermittently or continuously hot sanitized
- there is some history in the U.S. Pharmacopeia and Japanese Pharmacopoeia of using RO and UF for WFI

The most significant disadvantage is that EP does not allow a WFI production method other than distillation and therefore, WFI membrane use is limited to non-EP applications. The history of membrane based WFI system usage is significantly less than with distillation, and this has negatively affected confidence in membrane systems among some pharmaceutical companies. Additionally, the RO system requires periodic cleaning, the membranes must be replaced at some point, and membranes can fail just as any technology has failure mechanisms.

Capital and operating cost comparison for distillation and membrane based systems is a key element of system choice when regulatory requirements do not dictate distillation only. This article does not provide costs for several key reasons. Equipment specifications for materials of construction, instrumentation, control, and other major cost factors impact capital costs significantly and capital costs are meaningless without detailed specifications. Operating costs are directly impacted by utility costs for water, wastewater, power, steam, chilled water, and others and vary tremendously site to site. These costs are best based upon actual conditions case to case for accurate analysis. The significant possibility of lower life cycle economics for membrane based systems is based upon the relative absence of distillation based systems in non-regulated high purity applications.

## Why Has Membrane-Based WFI Production Failed to Flourish?

With all the potential advantages of using membrane-based technologies for producing WFI, why has it not caught on in the industry? For one reason, when RO was first approved for use in WFI production, the technology was not completely “ready” for this application. Hot-water-sanitizable RO did not exist, and chemical sanitization is not as effective as heat. Full-fit RO membrane elements were not available and neither was continuous hot operation. Early failures discouraged use, and while endotoxin control was not a problem, microbial control was. Ultrafiltration technology, while “ready,” did not have USP or EP approval.

Membrane technology has a significant successful history in production of WFI in Japan and in the US, but membrane system implementation is limited to facilities or applications where the EP requirements are not a factor. Since a significant percentage of pharmaceutical manufacturers produce for the European market, the EP distillation requirement stifles membrane implementation.

## Conclusions

Most WFI systems are distillation based. Distillation has a lengthy successful history in WFI production. Most other high purity systems in other markets use membrane processes rather than distillation, but no regulatory requirements exist. Water quality specifications for use such as microelectronics

manufacturing often greatly exceed WFI quality requirements.

USP and JP allow membrane based designs as well as distillation. The EP requirement for distillation eliminates any choice of alternate technologies for companies wanting to comply with EP. Therefore, membrane based systems are only employed where EP compliance is not required or where “WFI quality” water is desired, such as for meeting the requirements of EP Highly Purified Water, preparation of intermediates, or other uses.

Although some successful membrane-based systems have been in operation for several years, the historical database is not nearly as large as for distillation. Membrane-based systems are beginning to be placed and are considered more frequently because membrane-based systems may offer lifecycle cost advantages in reduced capital or operating costs. The choice is one of many risk-based decisions in the pharmaceutical industry. Users need to consider product, market, capital cost, utility costs, commissioning/qualification, maintenance, and risk to make an informed decision.

## Case Study for WFI Production: Alkermes, Inc.

The following case study is for a membrane-based WFI system in a US facility. A case study for distillation is not presented because distillation is well established. The distillation operating history is generally good and advantages and disadvantages are well understood.

### Background

Alkermes pulmonary drug delivery platform technology enables delivery of both small molecules and complex macromolecules to the lungs. This system can provide efficient dry-powder delivery of small molecule, peptide, and protein containing drug particles to either the deep lung or the upper respiratory tract, based on the product needs. Alkermes designed and built a manufacturing facility to support production of late stage clinical supplies as well as commercial production of its pulmonary drug delivery products. The manufacturing operations at the site include spray drying to produce the bulk dry powder, capsule filling, packaging, CIP systems for cleaning, and a clean steam system. The purified water system was designed to support the formulation activities associated with production of the bulk powder in the spray drying operation, the CIP system for cleaning process equipment, and as feed water to the clean steam system.

### Introduction

Dry powder inhalation products are typically not produced under aseptic manufacturing conditions. Based on this, the initial project requirements specified USP Purified Water as the appropriate grade of water for the manufacturing site. This decision was revisited after detailed engineering had been completed on the project. The review team identified a potential for tightening of microbial specifications in the final drug product, particularly for products that might be used in patients with compromised immune systems. Based on this

assessment, it was decided that the microbial specifications of the water should be tightened to support the current as well as any future drug product microbial and endotoxin requirements.

The water system had already been ordered and was in fabrication when the system requirements were changed. The Alkermes engineering team met with the system supplier to identify solutions that could meet the revised water system requirements, while minimizing the impact on the cost and schedule of the project. Several options were discussed, including the option of the reverse osmosis and continuous electrodeionization (CEDI) systems that were already specified as being able to meet the new requirements, and installation of a still to produce WFI grade water. The team identified the addition of an ultrafiltration step as the best way to meet the tightened water specifications, while minimizing the cost and schedule impact to the project. The system supplier was willing to guarantee that with the addition of an ultrafiltration step, the water generation system would be able to meet USP Water for Injection specifications with regard to microbial and endotoxin requirements.

The ultrafilter unit operation is relatively small physically and had a minimal impact on the layout of the generation and distribution system. This minimized any costs associated with piping layout changes. It also minimized the schedule impact because it did not require significant re-piping to accommodate the ultrafilter unit into the layout. The ultrafilter

unit and hardware also had short lead times, which further minimized the impact to the overall project schedule. In addition, the capital cost of the ultrafilter system was relatively small. This minimized the impact to the project cost.

### **System Description and Discussion**

The Alkermes water system is designated as an EP Highly Purified Water (HPW) System. The system consists of a generation system that is supplied with city water and produces up to 8 gpm of highly purified product water that meets USP, WFI test specifications. The product water is supplied from the HPW generation system to the top of a 3,000 gallon hot storage tank that is maintained at 80°C. The hot water storage loop is continuously circulated by pumping water from the bottom of the storage tank, through a heat exchanger, and back into the top of the storage tank. If the storage tank is full, the product water is circulated back to the HPW generation system as feed water.

The HPW distribution loop is self contained and normally maintained at room temperature or 24°C. The HPW distribution loop and hot storage loop are connected so that when water is drawn from the distribution loop, hot water is supplied from the storage loop to the distribution loop. A heat exchanger in the HPW distribution loop cools the water prior to feeding the water out into the plant and to the use points. Every 24 hours the cooling heat exchanger is turned off and the HPW loop is heated to 80°C and held

*Continued on page 26.*

GE Water & Process Technologies  
Analytical Instruments

## Proven performance. Proven results.

### The wise choice for TOC when every dollar counts

For decades, major global pharmaceutical manufacturers have trusted **Sievers Total Organic Carbon (TOC) Analyzers** from GE Analytical Instruments to deliver cost savings, accurate results, and productivity enhancements. With today's tight budgets, minimizing risk and maximizing return on investment is critical. Sievers TOC Analyzer customers regularly report significant savings, including:

- An 82% reduction in TOC laboratory samples for USP water testing
- More than \$500,000 in cost savings from switching to on-line TOC analysis
- IOPQ execution in less than five days
- 92% cost savings in cleaning verification costs by moving to at-line analysis

Find out how we can help you improve your bottom line. Visit [www.geinstruments.com](http://www.geinstruments.com) or contact us at [geai@ge.com](mailto:geai@ge.com) or 800-255-6964.



Sievers TOC Analyzers — the safe, proven choice for accurate, reliable TOC testing

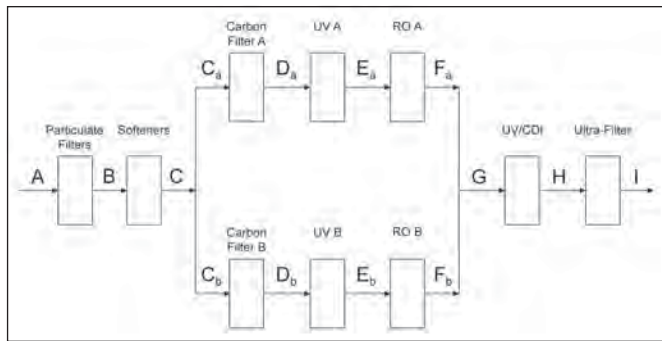

Figure 1. Process flow diagram for the HPW generation system.

at temperature for 60 minutes. The system design is based on the “Hot Storage – Self Contained Distribution” design that is described in the ISPE Baseline® Guide on Water and Steam Systems.

The overall water system includes several unit operations to meet the required product specifications. City water from the Massachusetts Water Resource Authority system is filtered using a multi-media filtering system to remove coarse particulates. The first unit operation in the HPW generation system is the particulate filter system. The particulate filters are nominal 5.0 µm cartridge filters designed to remove large particulates from the incoming feed water. The particulate filter system includes two banks of five cartridge filters, each of which can be operated in parallel with either one or two units in operation.

The next stage in the HPW generation system is a duplex water softening system. The water softening system is an ion exchange process that is designed to remove divalent and trivalent ions from the incoming city water and replace them with a monovalent sodium ion. The softening process prevents scale in the reverse osmosis unit downstream.

Two activated carbon filter skids in parallel are located downstream of the water softeners. The carbon filters are designed to remove chlorine from the feed water. Chlorine is added by municipal authorities to the city water as a microbial control agent. Chlorine can oxidize the reverse osmosis membranes and negatively impact system performance. In addition, it is recognized that the carbon beds can serve as an environment

for microbiological growth once the chlorine is removed. The heat sanitization cycles for the carbon filters are designed to control the bioburden levels in the carbon filters.

Ultraviolet (UV) lamp units are installed downstream of the carbon filters for inhibiting microbial growth after the chlorine has been removed by the carbon beds and prior to feeding the RO membranes with the in process water. The intensity of the UV lamps is monitored and documented in rounds sheets during routine operations of the system.

The next stage in the HPW generation system is the reverse osmosis process, which is part of the final treatment system. The system includes single pass RO membranes. The RO process is a pressure driven process with a semi-permeable membrane designed to remove minerals, organics, particulates, microbiological material, and endotoxin. The RO membranes reject a significant portion of the feed stream, while allowing a portion of the purified water stream to pass through the membrane. The daily performance of the RO membrane is monitored by measuring the percent rejection of conductive elements in the feed water to the reverse osmosis unit.

The CEDI unit is located downstream of the RO membranes and removes ionized species from water using electrically active media and electrical potential to effect ion transfer. The CEDI system is a continuous process in that the ions are continuously removed and the ion exchange resins are regenerated continuously. In addition, there is a UV unit as part of the CEDI skid. As discussed above, the UV unit is designed to limit microbial growth.

The last unit operation in the final treatment portion of the HPW generation system is the ultrafiltration system. The ultrafilter (UF) includes a 0.05 µm single pass filter and is designed to provide the final step in meeting the WFI specifications. Figure 1 includes a process flow diagram indicating the different unit operation steps in the HPW generation system.

Heat is used to sanitize both the HPW generation system and the HPW distribution system. The carbon filter, reverse osmosis skid, and associated piping are sanitized weekly using 80°C water. The entire generation system, including the carbon filter, RO skid, CEDI system, ultrafilter, and associated piping

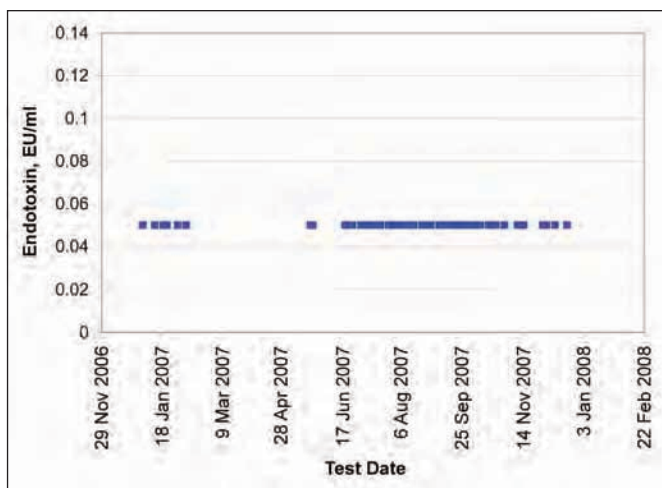

Figure 2. HPW generation system outlet.

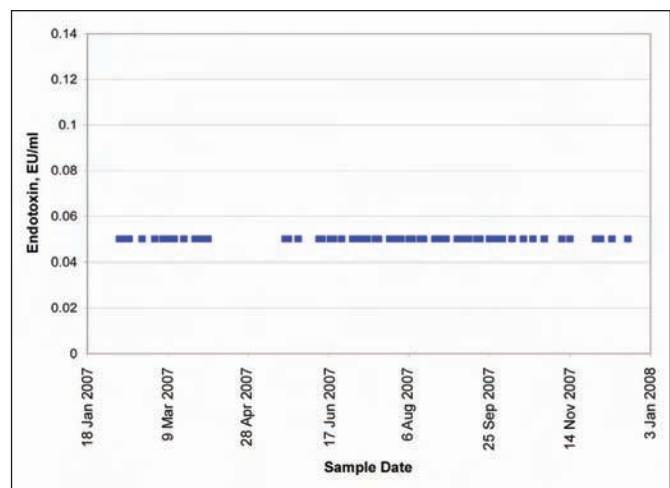

Figure 3. Formulation tank supply valve.

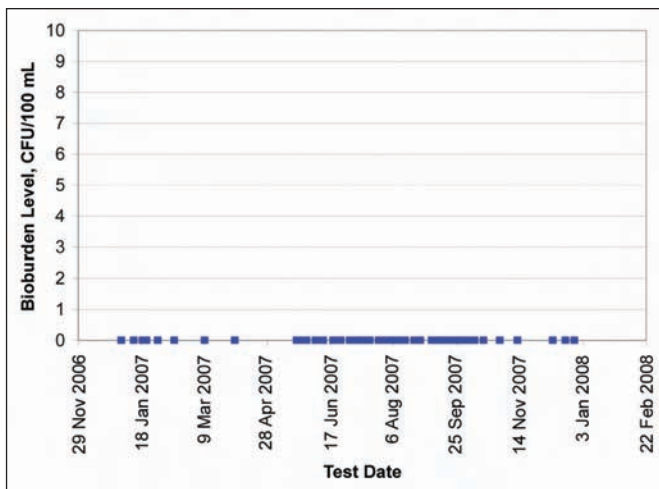

Figure 4. HPW generation system outlet.

is heat sanitized monthly. The distribution system is sanitized nightly by heating the entire distribution loop to 80°C.

The HPW generation and storage and distribution system was routinely monitored with a combination of inline and offline testing to confirm that the system was performing as expected. Critical performance attributes were identified for the unit operations within the generation system, along with appropriate test methods and acceptance criteria. The performance attributes were routinely monitored to confirm that the system was performing as expected. This includes, for example, routinely monitoring the free chlorine and bioburden levels after the carbon filter. In addition, the storage and distribution system was monitored at various points throughout the system. This included a rotating schedule of sampling various use points and testing for bioburden, endotoxin, conductivity, TOC, heavy metals, and nitrates. Appropriate specifications were established for the use point monitoring that included alert and action levels for the various attributes. Data and acceptance criteria are presented below.

### Data Discussion

As discussed above, the HPW was used for cleaning operations, clean steam feed water, and for formulation activities in producing dry powders used for inhalation therapies. Alkermes identified test attributes and specifications along with acceptance criteria that were appropriate for the intended use of the water. The specifications met the standards outlined for WFI compendial grade water.

The HPW storage and distribution system was sampled and tested on a routine basis to monitor the quality of the water. The schedule included sampling and testing of water from various points in the HPW storage and distribution system. Data is presented below from the January through December 2007 period that demonstrates the overall performance of the system. The data includes test points from the outlet of the generation system before the product water enters the storage and distribution system as well as at use points within the storage and distribution system.

Endotoxin test data is presented from two different sample points in the HPW system. Figure 2 includes data from the

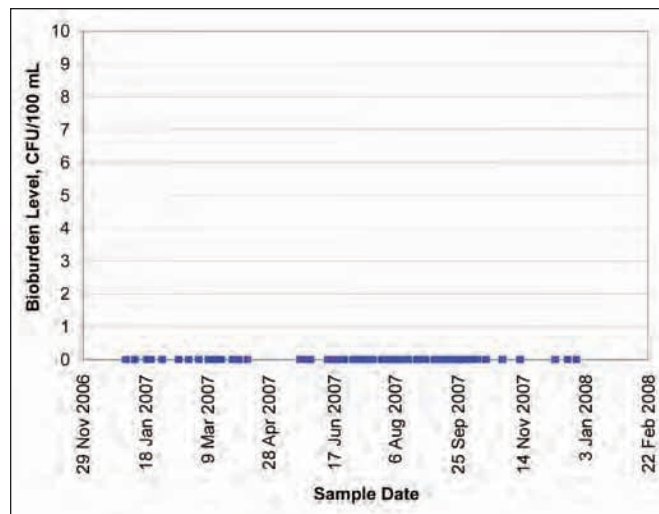

Figure 5. Formulation tank supply port.

generation system outlet. Figure 3 illustrates data from a charge port on the distribution system which is used to fill a formulation tank. In both cases, all samples were found to be below the detection limit of 0.05 EU/mL, which satisfies the alert limit of Not More Than (NMT) 0.13 EU/mL.

Total aerobic bioburden test data is presented from two different locations in the HPW system for the period January through December of 2007. Figure 4 includes data from the outlet of the HPW generation system. Figure 5 includes

*Concludes on page 28.*



**Murray Company**  
MECHANICAL CONTRACTORS

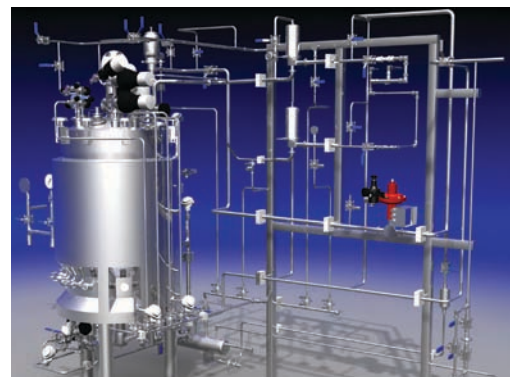

### A Proven High Purity Piping Contractor

Murray Company has built its reputation in the industry with our strong commitment to installing high purity piping and fabrication, as well as providing proven standard operating procedures tailored to FDA protocol with in-house Level 2 trained inspectors. We take pride in offering a turnover package that has been repeatedly praised by our clients for the ability to help expedite system validation. We ensure the quality of every project from start to completion.

2919 E. Victoria Street, Rancho Dominguez, CA 90221  
P 310.637.1500 • F 310.604.0359  
www.murraycompany.com

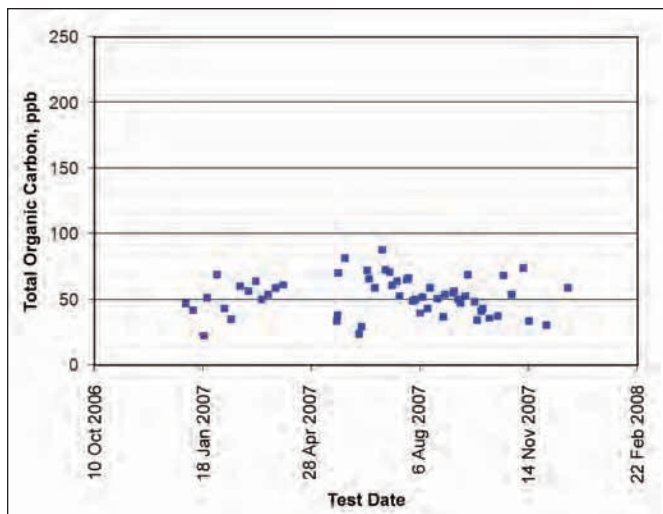

Figure 6. Formulation tank supply port.

data from a charge port on the distribution system, which is used to supply a formulation tank. In both cases, all test data from the ports were non-detectable for bioburden or below the alert limit of NMT 1 CFU/100 mL.

Total Organic Carbon (TOC) data is presented for the formulation tank charge port, which is located on the HPW distribution system. The data is plotted in Figure 6. The acceptance criteria include an alert limit of NMT 250 ppb. All values tested during the January to December 2007 period were below the alert limit of 250 ppb.

## Conclusions

This case study presented data demonstrating that WFI can be produced using a membrane-based water purification system. Monitoring data from a calendar year are presented for several critical performance attributes of the HPW generation and distribution system. All of the critical performance attributes met the standards outlined for WFI compendial grade water.

A membrane-based water purification system was chosen to minimize cost and schedule impact when the design basis was changed during the construction phase of Alkermes' manufacturing site. The addition of an ultrafiltration unit operation, which is compact in size, minimized the impact on the design and layout of the overall water system. The ultrafilter had a relatively short lead time and the capital cost was low. In addition, the operating cost of the ultrafiltration unit is significantly lower than the operating cost of a still, minimizing the impact on operating costs.

## About the Authors



**Henry Brush** is the Director of Manufacturing and Process Development at Alkermes, where he has developed the manufacturing process technology for the pulmonary drug delivery platform. This includes leadership roles in the scale-up of the manufacturing process to a high volume commercial operation, clinical

production operations, manufacturing plant design and commissioning, and manufacturing technical support. Prior to Alkermes, Brush has developed manufacturing technology at Acusphere, PerSeptive Biosystems, and Polaroid. Brush is currently a member of ISPE and has served on the Board of Directors for the ISPE Boston Chapter. He received his BS in materials science and engineering from MIT, and his MS in chemical engineering from Northeastern University. He can be contacted by email: [brush@alum.mit.edu](mailto:brush@alum.mit.edu).

Alkermes Inc., 88 Sidney St., Cambridge, Massachusetts, 02139-4137.



**Gary Zoccolante** is Pharmaceutical Technical Manager at Siemens Water Technologies. He has more than 30 years of experience in the design, operation, and trouble-shooting of pharmaceutical water systems, and has been involved in the development of equipment for pretreatment, reverse osmosis, deionization, ultrafiltration, and distillation. Zoccolante

was a task team member of the original ISPE Baseline® Water and Steam Systems Guide and is part of the task team currently updating the guide. He has been part of the Guide Presentation Team on several occasions. He was involved in face-to-face meetings with the FDA to help resolve many of the Guide principles. He is a member of the ISPE Critical Utilities Community of Practice Steering Committee. He worked on the development of the ISPE Good Practice Guide: Commissioning and Qualification of Pharmaceutical Water and Steam Systems. He has been selected to deliver the first public presentation of the Guide. Zoccolante developed the four day ISPE Pharmaceutical Water course and has presented the course to hundreds of pharmaceutical industry personnel, including the FDA. He is a frequent lecturer for many pharmaceutical groups and has chaired many courses. He has presented for ISPE, Interphex, American Institute of Chemical Engineers, American Society of Mechanical Engineers, Institute for International Research, Center for Professional Advancement, PDA, Pharmtec, Barnett International and many others. He has conducted several in-house courses on pharmaceutical water production and regulatory requirements for pharmaceutical companies. He has authored and co-authored many papers on pharmaceutical water production and system operation and maintenance. He holds several patents for pharmaceutical water processes. He has previous experience as manager of engineering and manager of application engineering. He holds a BS in mechanical engineering from Northeastern University. He can be contacted by email: [gary.zoccolante@siemens.com](mailto:gary.zoccolante@siemens.com).

Siemens Water Technologies Corp., 10 Technology Dr., Lowell, Massachusetts 01851-2728. 

INTERPHEX



# INTERPHEX™

## Conference & Exhibition

*Connecting Life Science Professionals Globally*

- *World Class Exhibitors & Attendees*
- *Comprehensive Education Programs*
- *Face-to-Face & Online Networking*

**NEW YORK**  
[www.interphex.com](http://www.interphex.com)  
 April 20-22, 2010  
 Jacob K. Javits Center  
 New York, New York

**PUERTO RICO**  
[www.interphexpuertorico.com](http://www.interphexpuertorico.com)  
 March 4-5, 2010  
 Puerto Rico Convention Center  
 San Juan, Puerto Rico

**CANADA**  
[www.interphexcanada.com](http://www.interphexcanada.com)  
 September 16-17, 2009  
 Metro Toronto Convention Center  
 Toronto, Ontario



**INTERPHEX365™**  
 Connecting Life Sciences Professionals Globally  
[www.interphex365.com](http://www.interphex365.com)

- Industry News
- Global Supplier Directory
- Meetings & Events
- Education & Training
- Community
- Careers

*Year Round Industry Access*  
[www.INTERPHEX.com](http://www.INTERPHEX.com)



Sponsored By:



**ISPE**  
 ENGINEERING  
 PHARMACEUTICAL  
 INNOVATION

Media Sponsors:



**PHARMACEUTICAL  
 ENGINEERING**



**Pharmaceutical  
 Processing**



**Pharmaceutical  
 Technology**

This article describes Amplified Media Circulation (AMC), which is an alternative option to the use of intrinsic sterilizer fans.

## Amplified Media Circulation – A New Way for Enhancing Sterilization Cycles

by David A. Karle, Gerald McDonnell, and Teppo Nurminen

### Introduction

Any mechanical moving part in a clean environment can present unique challenges to a manufacturing facility. For example, in the terminal sterilization of fluids, the associated sterilizer moving parts can include conveyors (for loading/unloading of the chamber) and impellers (or fans) within the sterilization chamber for heating/cooling purposes. Sterilizer fans are widely used to optimize the steam sterilization of loads (e.g., for providing laminar steam and air flow for good temperature distribution or for enabling enhanced cooling times), but are a particular problem as they are enclosed within the chamber of steam sterilizers. In addition to the requirement for emission-free operation for the fans, the hot, moist, pressurized conditions associated with steam sterilization result in an extra stress on these mechanical devices to include the bearings, shafts, and in the routine maintenance (e.g., lubrication) of such components. Further, chamber penetrations associated with fans require extra design requirements and utility supply, e.g., ultra pure water or distillate

for sealing purposes in powering the fans. Even with magnetic coupling technology, problems with particulate emissions, lubricant contamination, and bearing endurance can be a concern with traditional fan designs. In this article, an alternative option to the use of intrinsic sterilizer fans is presented, which is referred to as Amplified Media Circulation (AMC).

### Alternative Method and Design

Recently, a new method for enhancing air, steam, liquid, and/or gas movement in sterilization processes has been developed. The movement of air or other process fluids within a chamber, such as steam, can be amplified by methods other than mechanical agitation (the use of fans). An example is using the “venturi” effect. The venturi effect is actually a rather old concept, named after the Italian physicist Giovanni Battista Venturi (1746-1822). It is based on the premise that a high-speed liquid or gas generates a local vacuum through the kinetic energy of the flowing molecules. Although this might not be obvious, this phenomenon is used in many common devices, such as car carburetors, gas stoves,

Figure 1. Principle of venturi effect.

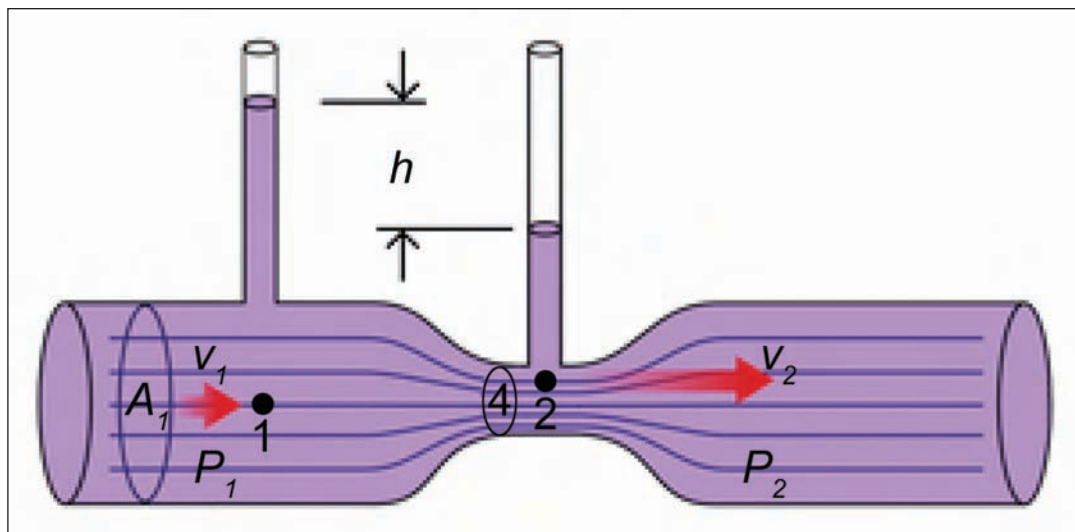

Continued on page 32.

Reprinted from  
**PHARMACEUTICAL  
 ENGINEERING®**  
 The Official Magazine of ISPE  
 July/August 2009,  
 Vol. 29 No.4  
 ©Copyright ISPE 2009  
 www.ISPE.org

# Pharmaceutical Processing Systems

GEA Pharma Systems supplies the world's pharmaceutical companies with state-of-the-art solutions for the processing of active pharmaceuticals, ranging from the processing of API (Active Pharmaceutical Ingredient) to the production of solid dosage forms and sterile liquids finishing.

The GEA Pharma Systems portfolio of leading industry brands includes:

- Aeromatic– Fielder and Collette granulation/drying systems
- Buck contained materials handling systems
- Courtoy advanced tablet presses
- Niro spray drying technology
- Lyophil freeze drying systems including automatic loading and unloading

The combination of these strong brands with a deep commitment to research and development has resulted in GEA Pharma Systems establishing a leading global market position.



Engineering Excellence.

## GEA Pharma Systems

9165 Rumsey Road • Columbia, MD 21045  
Tel 410 997 7010 • Fax 410 997 5021  
E-mail [info@niroinc.com](mailto:info@niroinc.com) • Website [www.niroinc.com](http://www.niroinc.com)



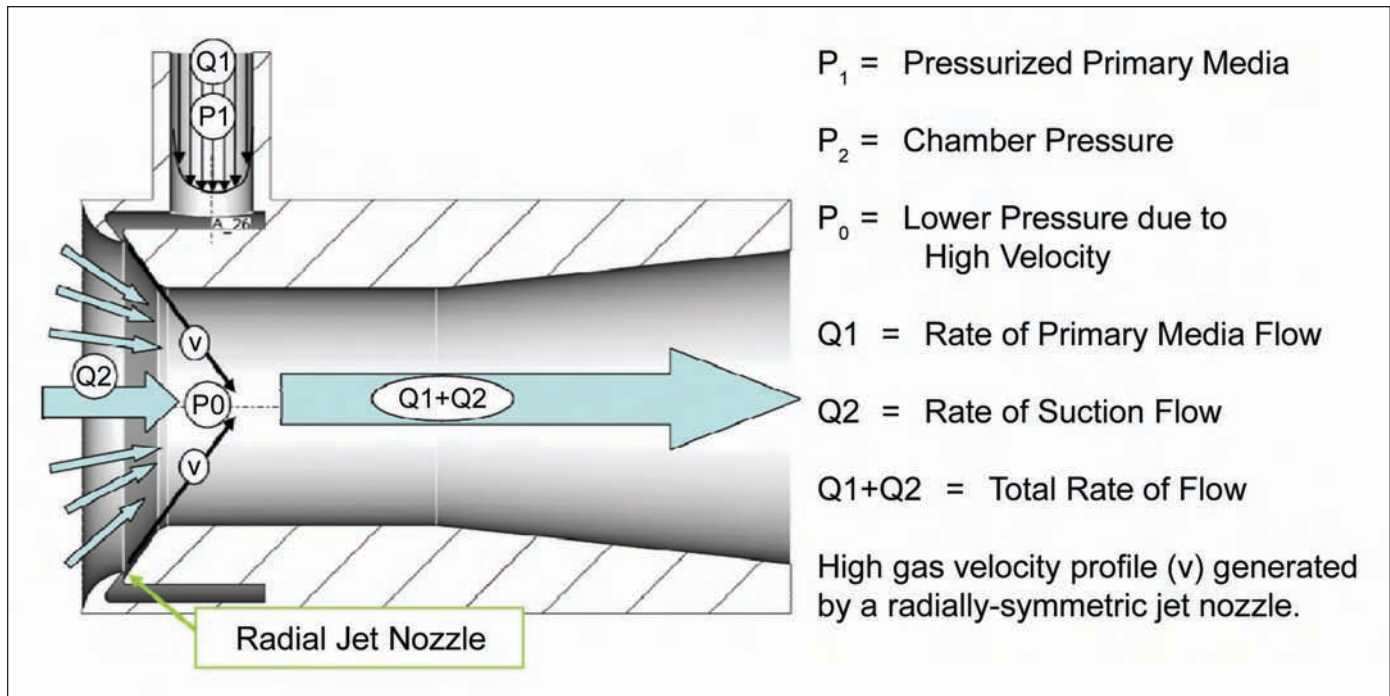

Figure 2. Principle of the AMC ejector.

or paint atomizers. In Figure 1, the venturi effect manifests itself as the hydrostatic pressure difference (h) between high and low velocity areas of the demonstration device.

For specific application to enhanced sterilization cycles, AMC differs from the traditional venturi pipe system due to the configuration of the associated flow channels. Whereas in a basic venturi design the primary flow in the main channel induces a negative pressure component into the side channel(s); in the case of AMC for sterilizer applications, the channel arrangement is the opposite. Primary media (like air) is injected into a narrow side channel, from which it flows into the main channel through a radially-symmetric capillary gap at the inlet end of the channel. The concave shape of the final section of the side channel redirects the flow, making it enter the main channel in a skewed angle, pointing toward the other end (outlet end) of the channel - *Figure 2*. The subsequent angled flow generates a local vacuum into the main channel. This vacuum draws air (or other fluid) into the inlet end of the main channel, and as a result, the combined main flow (priming air and venturi-induced main flow) is typically about 20 to 30 times higher in volume flow rate than the primary flow was. In this way, the higher pressure in the compressed air supply is converted into higher, "amplified" flow rates in the main channel.

The primary air needed for powering the AMC device(s) can be taken from any source; for example, a typical steam sterilizer air supply. The air quality requirements are the same as for any air-powered process component, being dry, oil-free, and passed through a 0.22 micron filter to ensure its sterility. This arrangement is practically no different than any other terminal steam-air-mix sterilizing process or any associated liquid process for that matter since all of these require air to provide and maintain over-pressure. For example, in the sterilization of closed liquids, a pressure higher than saturated

steam pressure is routinely applied in order to maintain product integrity. Producing compressed air is relatively inexpensive, especially when compared to the requirements for producing distillate or similar quality water for fan installations. In sterilizer applications, the AMC devices' primary air consumption is typically from 22 to 72 m<sup>3</sup>/h at 4 bar working pressure (equaling 13-32 cfm at 58 psig), depending on the sterilizer size. These values are essentially equivalent to the typical air pressure required for an associated sterilization process, i.e., any process designed for processing liquid loads. The difference is that with AMC, the peak consumption is sustained throughout the cooling stage and the air compressor should be able to support this level of air consumption on a continuous basis. Essentially, this can be achieved when planning the utilities for process support to verify that the compressor capacity for generating required amounts of pressurized air exists. In a medium or large plant, these rates would not be considered unusual or high, and in most cases, an existing compressor would already possess the additional capacity required. As energy consumption is always a consideration, it is important that the additional electrical energy consumed by air compressor is below that of the energy consumed by most conventional fan motors; this is despite the fact that the AMC approach does not require the pure water supply for sealing the required penetration. Typically, the cost of the electrical energy consumed is estimated to be around one dollar (\$0.33 - \$1.13 or 0.25 - 0.85 € depending on the chamber size) for each cooling hour.

Utilization of AMC devices is not limited to process air. Steam also can be injected into the chamber through such devices, which also may be considered as "ejectors," which can result in enhanced temperature distribution and shortened heating up times. Steam itself can be efficient in its own

right, but nevertheless a definite improvement in heating up times can be witnessed when the steam flow was amplified by directing it through AMC devices. Also, the higher the steam velocities, the more dynamic and effective the penetration into the load items can be. As stated in a steam sterilizer validation guide, "determining which load items are the most difficult to sterilize and which location(s) within the items presents the worst-case conditions can be a daunting task."<sup>2</sup> Steam penetration speed during standard operating conditions can be calculated. Calculations are based on simple diffusion and convective flow,<sup>3</sup> but dynamic disturbances improve the penetration further by agitating the atmosphere mechanically. Consequently, in order to achieve an optimal performance, arrangements can be made for toggling the utility supplies automatically between ejector/no ejector inlets based on the process phase. Figure 3 illustrates a typical ejector pair installation in the ceiling of the sterilizer chamber.

### Practical Applications

An example of the practical use of the AMC principle has been shown for the rapid cooling of liquid loads. Figure 4 presents a typical liquid load with sealed bottles. A traditional, indirect (jacket) cooling of such load can take many hours. Enhanced with fans or other mechanical devices, the cooling stage can routinely be shortened by 50 to 60%. The AMC system meets or even exceeds the performance of currently used mechanical convection systems (fans), but does not possess any of their



Figure 3. Ejector installation in the sterilizer ceiling.

associated disadvantages. Figure 5 presents tests results with unaided natural cooling, indirect jacket cooling, fan-enhanced cooling, and cooling assisted with AMC.

Ejector design and function can be maximized for optimal performance and programmed permanently for that application. An added advantage is that the ejectors do not require maintenance, periodical checks, safety precautions, special cleaning, spare parts, or adjustments during the lifetime of the sterilizer. Importantly, they do not contain moving parts nor require lubrication. The entire ejector assembly to include both the external and internal surfaces, such as the capillary gap, is fully within the steam contact area. Consequently, the ejector(s) are sterilized each and every sterilization cycle, as

*Continued on page 34.*

**ARE YOU RELYING ON  
SAFETY PRODUCTS  
THAT "SHOULD" WORK?**



**FIKE IS COMMITTED TO RELIABLE SAFETY SOLUTIONS THROUGH RESEARCH, NEW TECHNOLOGIES, AND EXTENSIVE TESTING.**

- Comprehensive selection of ASME, CE and 3-A rupture/bursting discs
- High performance explosion vents, specifically designed for sanitary applications
- Complete line of products for CIP/SIP applications
- Dedicated team of combustion engineers and pressure relief experts

**DON'T LEAVE THE SAFETY OF YOUR BUSINESS TO ANYTHING LESS THAN THE MOST RELIABLE, PROVEN PRODUCTS.**



VENTING



SUPPRESSION



RUPTURE DISCS



TESTING

**PROVEN PERFORMANCE, QUALITY  
AND RELIABILITY FOR OVER 60 YEARS**

**Fike®**

1-866-758-6004

WWW.FIKE.COM



Figure 4. Typical liquid load configuration.

with the chamber and associated piping. Actually, the sterilizing steam enters the pressure vessel through the ejector(s), meaning that they are intrinsically the hottest spot in the chamber and therefore, inevitably become sterile. Contrary to this design, traditional impellers with water sealing may become a focus area in the sterility qualification as cold spots within the chamber. FDA guidelines suggest that special attention should be given to the sterilization of those locations slowest to heat.<sup>1</sup> The sealing water flowing through the shaft penetration, although not intended for cooling, may induce colder spots into that particular area.

Another advantage of AMC is that it occupies minimal space within the chamber. Whereas a fan assembly can be rather bulky and require auxiliary stainless steel constructions around it, the AMC ejectors are stand-alone devices extruding only a couple of inches from the chamber ceiling. Further, the ejectors do not require any associated electric motors on the top of the sterilizer, thus minimizing the height and installation size of the unit. The noise levels of the entire sterilizer,

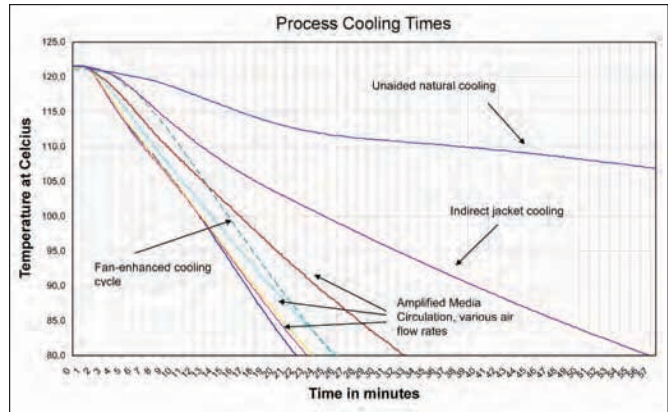

Figure 5. Comparison of various cooling methods.

including AMC devices have been independently verified not to exceed the OSHA or other safe criteria for operation.

Traditional terminal sterilization applications with fans have attempted to maximize laminar flow to optimize their use. This approach most often requires guides or baffles, thus restricting and redirecting the air flow and consuming chamber space. With AMC, the penetration is based on high air velocities which create the necessary turbulence within the chamber. During the cooling phase of a steam sterilization cycle, for instance, this turbulence prohibits stratification without the need for particularly guided flow patterns. Smooth and efficient cooling has been proven for representative full loads. Figure 6 illustrates the flow patterns during the cooling

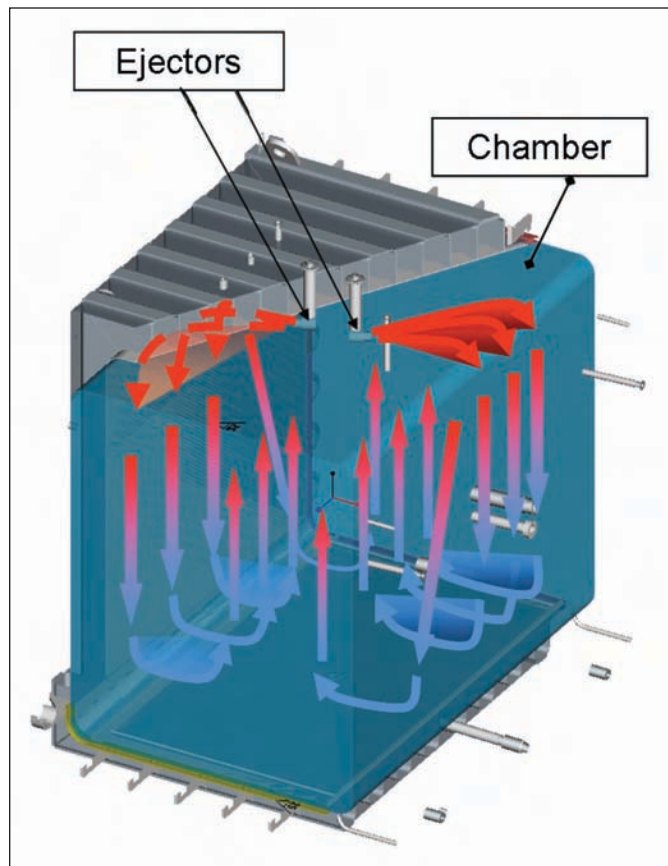

Figure 6. AMC flow patterns during cooling stage.

Date/Time	Temperature Probe Readings													
08-March-2007 09:06:00	121,20	121,10	121,10	121,20	121,10	121,20	121,20	120,90	121,20	121,10	121,10	121,10	121,10	121,50
08-March-2007 09:06:30	121,20	121,10	121,10	121,20	121,10	121,20	121,20	120,80	121,20	121,10	121,10	121,20	121,20	121,50
08-March-2007 09:07:00	121,20	121,10	121,10	121,20	121,10	121,20	121,20	120,80	121,20	121,10	121,10	121,20	121,20	121,50
08-March-2007 09:07:30	121,10	121,10	121,10	121,20	121,10	121,20	121,20	120,80	121,20	121,10	121,20	121,20	121,20	121,50
08-March-2007 09:08:00	121,20	121,10	121,10	121,20	121,20	121,20	121,20	120,90	121,20	121,10	121,20	121,20	121,20	121,50
08-March-2007 09:08:30	121,10	121,10	121,10	121,20	121,10	121,20	121,20	120,80	121,20	121,10	121,10	121,20	121,20	121,50

Figure 7. Typical temperature distributions with a full liquid load.

stage. Forced convection is induced by conveying the hot air rising through the load to the cold walls.

On the other hand, for some other stages of typical sterilization cycles (e.g., during the steam sterilization or holding phase) turbulent conditions should be avoided. The value of a pressure difference-driven device, such as AMC, is that when the pressure difference diminishes, the amplifying effect decreases in parallel. In this way, the flow rates come intrinsically down when the highest (or desired) pressures are approached. Subsequently, during the sterilization phase, the counter pressure in the chamber is at its highest, and the ejector flow rates are at their lowest and the delicate temperature balance can easily be maintained through this critical stage. Also, in the absence of shaft penetrations or cooling water for the shaft seal, cold spots or undesired convection of heat from the vessel are easier to avoid. Consequently typical, verified maximum distribution with a full load has been confirmed to be in the  $\pm 0.35^{\circ}\text{C}$  range (Figure 7) including the probe in the drain line. In an empty chamber, the distribution is normally within  $\pm 0.15^{\circ}\text{C}$  - Figure 8.

The same automatic adaptation applies to other phases of a typical sterilization cycle. During the post-sterilization cooling stage, higher flow rates are again desired (to enhance the forced convection and the heat transfer from the load), and the rates can be artificially boosted by allowing some air to escape from the vessel in a controlled manner. Mechanical agitators, such as fans, are typically running at the same speed throughout the cycle, and even though speed variation solutions that involve frequency drives can be implemented, the flow rates still do not adapt automatically to the process conditions as observed with the AMC devices. During the cooling phase, air is also exhausted from the vessel. The ASME pressure vessel codes state that the exhaust from the vessel must be piped to a safe place. Usually, the air exhaust from the chamber can be connected to the same pipeline, often leading to the outside of the building. If the safety device pipeline for some reason does not exist, the air could be vented directly into the room. In this case, the air flow rates must be taken

into account when designing the room ventilation. Often, the pressure differentials between various rooms are controlled accurately, and in cases like this, the air exhaust may not be allowed directly into the room, but must be piped either to the safety relief device line or to the drain line. In the latter case, the air exhaust should be segregated from the room with a water lock (siphon) to prevent the flow from disturbing the pressure differentials between controlled or clean rooms.

*Concludes on page 36.*





**Plascore Pharma™**

## Cleanroom Solutions

### Wall Systems and Walkable Ceilings

- Modular pharmaceutical wall and ceiling solutions.
- Demountable walls in progressive and nonprogressive options.
- Fully integrated doors and windows.
- Standard and custom finish options including painted, UPVC and stainless steel.

**Pharmaceutical  
Biotechnology  
Medical Research  
Life Sciences**





**PLASCORE®**

**Plascore, Inc.** 615 N. Fairview St., Zeeland, MI 49464  
 (800) 630-9257 sales@plascore.com www.plascore.com

Date/Time	Temperature Probe Readings												
13-May-2007 07:08:30	121,30	121,20	121,30	121,40	121,30	121,30	121,30	121,30	121,30	121,40	121,40	121,40	121,30
13-May-2007 07:09:00	121,30	121,20	121,20	121,30	121,30	121,30	121,30	121,30	121,30	121,40	121,30	121,40	121,30
13-May-2007 07:09:30	121,20	121,20	121,20	121,30	121,20	121,30	121,30	121,30	121,30	121,30	121,30	121,30	121,30
13-May-2007 07:10:00	121,30	121,20	121,20	121,30	121,20	121,30	121,30	121,30	121,30	121,30	121,30	121,30	121,30
13-May-2007 07:10:30	121,20	121,20	121,20	121,30	121,20	121,20	121,30	121,30	121,30	121,30	121,30	121,30	121,30

Figure 8. Typical temperature distributions with an empty chamber.

## Summary

Mechanical fans have been the traditional method for forced convection within steam sterilizer chambers. More modern alternatives to conventional fan, such as the AMC devices described in this article, can provide the same if not more efficient operation, but with less space within the chamber, with no moving parts to fail, requiring fewer utilities to operate and being virtually maintenance free. These advantages also can be provided to low temperature sterilization and other applications with similar technology.

## References

1. U.S. Department of Health and Human Services, Food and Drug Administration, Guidance for Industry: Sterile Drug Products Produced by Aseptic Processing – Current Good Manufacturing Practice, Rockville, Maryland, 2004.
2. Lewis, R.G., “Practical Guide to Autoclave Validation,” *Pharmaceutical Engineering*, July/August 2002, Vol. 22, No. 4, <http://www.ispe.org/pe>.
3. Nordhauser, F.M. and Olson, W.P., **Sterilization of Drugs and Devices**, Interpharm Press Inc., 1998, pp. 65-71.
4. Morrissey, R.F. and Phillips, G.B., **A Practical Guide for Manufacturers and Users of Health Care Products, Sterilization Technology**, 1993.

## About the Authors



**David A. Karle** is a Senior Product/Marketing Manager for Steris Corporation. He also is responsible for managing a team of professionals who work with pharmaceutical companies to develop sterilization cycles for their products. Karle started his career with AMSCO in 1974 as a senior research scientist.

He maintained that position for 11 years before joining the marketing group as a product manager for healthcare steam sterilizers. Since 1985, Karle has held various positions in product and marketing management of consumables and capital equipment in both healthcare and in the pharmaceutical businesses at AMSCO, which in 1996

became Steris Corporation. He can be contacted by telephone: +1-814-870-8578 or by email: [Dave\\_Karle@steris.com](mailto:Dave_Karle@steris.com).

Steris Corporation, 2424 W. 23rd St., Erie, Pennsylvania 16506 USA.



**Dr. Gerald McDonnell** has a BSc. (Hons.) in medical laboratory sciences from the University of Ulster and a PhD in microbial genetics from Trinity College Dublin. He is currently Vice President of Technical Affairs and Research for Steris Corporation, based at their European headquarters in Basingstoke, UK. McDonnell is widely published in the decontamination and sterilization area. His research interests include infection prevention, decontamination microbiology, emerging pathogens, and the mode of action/resistance to biocides. McDonnell is a member of the American Society of Microbiology, Society for Applied Microbiology, Hospital Infection Society, Council of Healthcare Advisors, European Biological Safety Association, PDA, and ISPE. He can be contacted by telephone: +44-1256-866560 or by email: [Gerry\\_McDonnell@steris.com](mailto:Gerry_McDonnell@steris.com).

Steris Limited, Steris House, Jays Close, Viables, Basingstoke, Hampshire RG22 4AX, United Kingdom.



**Teppo Nurminen** has a Master of Science (Eng) in applied electronics and control techniques from the Helsinki University of Technology. He has held various managerial positions at Steris Finn-Aqua since 1994, and he is currently a Manager for Research and Development at the Tuusula facility, Finland. Prior to Finn-Aqua, he worked as an engineering consultant. He is the inventor or co-inventor in numerous international patents related to pharmaceutical water treatment, steam sterilization, and biohazardous effluent decontamination. He can be contacted by telephone: +358-9-2585227 or by email: [Teppo\\_Nurminen@steris.com](mailto:Teppo_Nurminen@steris.com).

Steris Finn-Aqua, Teollisuustie 2, 04300 Tuusula, Finland. 

[www.ISPE.org/strasbourgconference](http://www.ISPE.org/strasbourgconference)



## Managing Knowledge through Science and Risk Assessment

**28 September - 1 October 2009**

Palais de Congrès  
Strasbourg, France

### Seminars:

- Commissioning & Qualification: Practical Applications of Science and Risk-based Approaches to Validation
- Disposables and Containment Technology in Biomanufacturing: Managing Risk, Reducing Cost
- *GAMP*<sup>®</sup>5 Operational Aspects
- Barrier Isolation Forum, Innovation Updates and New Case Studies

- Investigational Medicinal Product (IP) Innovation in a Regulated Environment
- PQLI<sup>®</sup>: Global Realisation and Implementation of the ICH Quality Vision

### Training Courses:

- Basic Principles of Computerised System Compliance (*GAMP* 5)
- Cleaning Validation Principles

ISPE Strasbourg Conference Exhibition is  
sponsored by:  **INTERPHEX**2009<sup>™</sup>  
Conference & Exhibition

ENGINEERING PHARMACEUTICAL INNOVATION



Sponsorship and Table Top Exhibit Opportunities Available

This article presents a case study on the area of utilities and facilities maintenance outsourcing within the pharmaceutical industry. This approach shows how the future for outsourcing is moving toward full ownership of utilities and facilities systems through long-term fixed contracts which have shown clear benefits for both parties involved.

## Maintenance and Facilities Outsourcing Excellence – An Industry Case Study

by Padraig Liggan

### Introduction

According to Jones,<sup>1</sup> it was found that in the early 1990s, as little as five percent of world class manufacturing organizations outsourced maintenance and facilities services. Within 10 years, by the end of the 1990s, this figure had risen to around 30%, particularly in the area of utility systems operations and maintenance. The outsourcing of maintenance at this time had started to reveal itself as a relatively new trend. Currently, in 2009, the number of world class manufacturing organizations who are outsourcing utilities and facilities operation and maintenance is estimated to be in excess of 40% and still growing.

The main reasons for outsourcing utilities and facilities maintenance are to allow the manufacturing company to focus on its core

activities of developing and producing product. Outsourcing the maintenance function can reduce costs by eliminating direct company headcount; enabling management to enforce change quickly, drive continuous improvement, and improve service levels. This is possible because the outsourcing company then becomes the ‘customer’ of this activity and is in a better position to demand the most for their money from subject experts.

The outsourcing of utility services within the pharmaceutical industry will in most cases include clean utility systems such as high purity water and steam systems (purified water, water for injection, clean steam) and cleanroom Heating Ventilation and Air Conditioning (HVAC). Facilities services will typically include building fabric maintenance, cleaning, and general building services administration. For the main-

Figure 1. The Wyeth Biopharma Campus at Grange Castle.



Reprinted from  
**PHARMACEUTICAL  
ENGINEERING®**  
The Official Magazine of ISPE

July/August 2009,  
Vol. 29 No. 4

©Copyright ISPE 2009  
www.ISPE.org

Continued on page 40.

# Solutions

## ANSWERS FOR ALL YOUR PROCESSING NEEDS

### In the Exhibit Hall:

- **Over 300 Exhibitors** - Leading manufacturers of process equipment, systems and technology for fluids, solids, and plant services.
- **NEW Technology Workshops** - An interactive opportunity to discuss specific solutions with participating exhibitors.

### In the Classroom:

- **NEW AIChE Day** - One-day Conference developed by AIChE addresses proven solutions to adapt to your projects.
- **Chemical Engineering Magazine Educational Conference** - Two-day program presenting practical seminars for more efficient process operations.
- **Nano & Green Technology Symposium** - Two-day Symposium and Workshop on the opportunities that currently exist to incorporate nanotechnology into your operations - developed by iRAP.

### OnLine:

- **NEW Matching Service** connects you with the exhibitors that have the right products and solutions you need.

**More to see, do and learn at the  
process industries #1 event.**

Free Show Registration and Information:

[www.chemshow.com](http://www.chemshow.com)



*The New*  
**CHEMSHOW**  
Processing Solutions  
for a Changing Marketplace

**November 17-19, 2009 | Javits Convention Center • New York City**

Produced and managed by:

INTERNATIONAL EXPOSITION CO.

Telephone: 203-221-9232 • E-mail: [info@chemshow.com](mailto:info@chemshow.com)

Endorsing Associations:

AIChE

FCI  
Fluid Controls Institute, Inc.

FLUID SEALING  
ASSOCIATION FSA

ICAc

VMA



tenance outsource provider, customer satisfaction is a primary area of focus, which is a motivation for the expert service provider to deliver a best in class, value for money service, not necessarily felt as deeply as in-house staff. Outsourcing partners are generally non-unionized and so the risks of strike or halts to manufacturing as a result are extremely low.

By setting out clear objectives and outsourcing to an experienced company, great results can be achieved. Outsourcing should not be mistaken with relinquishing of overall responsibilities. For example, in the pharmaceutical industry, legal aspects such as regulatory compliance for drug manufacturing must be maintained and closely monitored and the outsourcing company must provide safe systems of work. Outsourcing of utilities (particularly clean utilities) and facilities should be a risk-based approach where over time, the contract company becomes more empowered through satisfaction by the client company that high quality services can be consistently delivered. The company also should employ people to monitor performance of the outsourced contract and to develop service level agreements. All the major manufacturing companies in Ireland have adopted various degrees of maintenance and facilities outsourcing as part of their business strategy. This has paved the way for a new emerging industrial services business sector in Ireland: outsourcing services, such as facilities, maintenance, and security. Competition in these areas is healthy, which of course encourages the industry-wide provision of better value for money. This is allowing Irish companies to build expertise in these areas by being able to support large multinational companies who wish to set up in Ireland. This ability of these service companies can be a positive factor in the decision-making process of a company potentially choosing Ireland as a location.

## Building Outsourcing Excellence

In 2001, it was announced that pharmaceutical giant Wyeth was to invest €1.8 billion (\$1.8 billion) in a state of the art biopharmaceutical plant at Grange Castle, West Dublin. Later that year, the construction of one the world's largest biopharmaceutical plants began at Grange Castle - *Figure 1*.

In 2002, maintenance outsourcing began with the externalization of the utilities and facilities maintenance organization in order to operate plant utilities and to setup maintenance programs for the site. Although we don't often see plants of this size being constructed, this is the best time to form an alliance partnership with the maintenance outsourcing company, working together from the start, regardless of plant size.

Since 2002 to the present, Wyeth and its outsourcing strategies have evolved to form one of the best examples of outsourcing excellence in Ireland today. There are a number of key areas that have contributed to this success.

## Utilities and Facilities Outsourcing: A Self-Managed Service

Wyeth expects and encourages the outsourcing companies to have a high degree of ownership when it comes to operating and maintaining utility/facilities systems. In each manufacturing area, the contract is overseen by one Wyeth cost center owner

who monitors contract performance and contract spend. This structure is beneficial to Wyeth and they don't need to get involved in the day to day running of the plant. Through the cost center owner, Wyeth management has a good visibility of the performance of the contract and the areas that may need to be addressed. Performance is measured through areas, such as availability, planned work vs. actual, safety and regulatory requirements. For clean utility systems (which are qualified systems and feed manufacturing areas directly), high level compliance is ensured through Wyeth subject matter experts and the Quality Assurance group in each area. Wyeth has overall responsibility for the safety of their products and this structure needs to exist. Figure 2 details the type of organizational structure that has been set up for the outsourcing of utility systems in manufacturing areas.

The outsourced teams interact with local quality groups and manufacturing area owners on a daily basis as would occur in any pharmaceutical organization. Overall, the contract is overseen by a client operations manager along with client quality support. One of the key advantages of this structure is that the outsourced company can be measured directly against the equipment/system uptime that is being provided; this is because they own every activity within the maintenance organization. In some outsourcing situations, only certain tasks are contracted (also known in industry as "body shopping"). In this scenario, it can be difficult for the company to achieve full accountability from the contractor for systems performance. Where the outsourced company has a high degree of ownership of systems, continuous improvement is a natural evolution, and this should be supported and encouraged by the client company.

A service level agreement sets out clear expectations and tasks to be performed by the outsourcing partner. The manufacturing companies' measurement of the contract is important; company's can't manage what they don't measure, and this is where Key Performance Indicators (KPIs) have a part to play. The KPIs can be structured in terms of plant availability, scheduled work completion, and safety and compliance with specific targets, among others. Penalty clauses can be employed for performance targets that are not met, this approach creates a mutual gain "win-win" (i.e., both share the risks and rewards) environment in which all parties see the benefit of high performance.

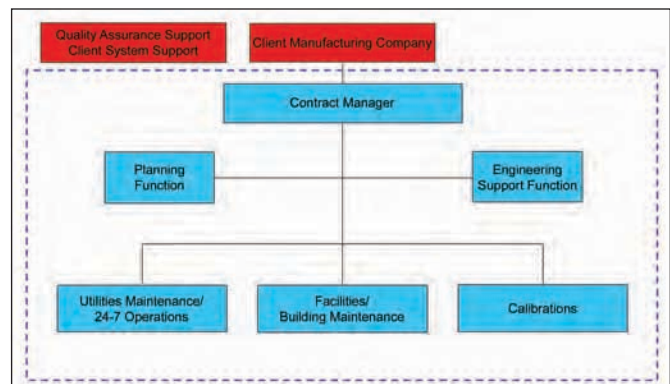

Figure 2. Typical outsourcing organization chart for utilities/facilities.

Within the outsourcing structure, the internal site training systems should be adopted by the contract company for areas such as procedural, GMP, and safety compliance. There should be an expectation that the outsourced company will continually develop their own employees by providing additional technical/equipment specific training.

By creating the outsourced maintenance function as a separate entity, it means that whatever is happening in production, good or bad, the utilities and facilities equipment/systems performance is not compromised. In cases where the maintenance function is in-house, the company departments have tendencies to abandon the maintenance function temporarily in order to sort out problems in production, which can potentially lead to system performance and regulatory compliance suffering due to lack of focus.

### An 'Alliance Partner' not 'Contractor'

Utilities and facilities outsourcing plays an important role in the day-to-day operation of the Wyeth plant in Grange Castle and for this reason, high recognition is given to the outsourced company by providing them with internal facilities such as training, computer network access, and opportunities to become involved in site business initiatives. Instead of being "housed away in the back-yard," the outsourced company operates alongside Wyeth on a daily basis.

The term "contractor" is very rarely used, rather an "Alliance Partner" with Wyeth. In many plants, the outsourced

company is often referred to as "those maintenance people" and this stigma creates an "us versus them" relationship, which can inhibit improvement, hinder trust, and have a negative effect on overall plant performance.

All of the above approaches by Wyeth create a true partnership between the client and the outsourced partner, and the relationship is based on mutual trust and mutual gains.

### Building for the Future

At present in Irish industry, companies are in the process of negotiating long-term contracts with utilities and facilities service companies who take over full ownership of the plant. This type of approach can provide for a "Black Box" service, which further enables the client company to reduce overall costs and focus on their core business. This sort of contract arrangement is set to become the future for outsourcing of utilities and facilities.

Again this is a win-win situation for both parties; on one hand, the manufacturing company has an ability to set long term fixed budget costs for each year in return for the supply of utilities and facilities services. For the outsourced company, an operational profit is made over the term of the contract, and investment can be made for the long term development of its people without the fear of losing them through loss of short term contracts. Typical KPI measurements are as follows:

*Concludes on page 42.*

## Push a button and walk away



## Automate your TOC analysis



Be Right™

## Anatel PAT700: The first TOC analyzer for on-line release

- Simplify validation and reduce operator intervention with OASIS™ Onboard Automated Standards Introduction System
- Provide peace of mind, superior reliability and uptime with UV Detect™ and advanced diagnostics
- PAT design for compliance in the most demanding regulatory environments

**Call or email to schedule your demonstration:**

HACH COMPANY World Headquarters  
Toll Free: 800-866-7889  
Fax: 970-461-3914  
Email: [orders@hach.com](mailto:orders@hach.com)  
[www.hach.com](http://www.hach.com)

- Utility Systems Plant availability (expectations >99.5%)
- Quality Compliance (CAPA Investigations timely closure, maintenance scheduled Vs complete)
- Safety (number of incidents, no lost time injury)
- Innovations/plant efficiencies/energy savings (bonus payment provisions in place)
- Facilities response times and timely closure of logged items

With a strong outsourcing partnership in place, it is estimated that the pharmaceutical company can expect to make savings in excess 20% in comparison with the alternative internal structure. With a long term fixed price contract, it is within the outsourced company's own initiative to continuously improve in order to gain a higher profit margin on best efficiency and performance of high availability utilities being sold back to the client.

## Design, Finance, Operate, and Maintain

During the construction of a new plant, another popular option is to completely outsource the plant core utilities. Some outsourcing companies can design, build, finance, and operate and maintain the central utilities plant, which can include steam, electricity, air, water, etc. With this arrangement the client company can focus on getting its manufacturing facilities up and running and be supplied with plant utilities which can be purchased at unit cost. At an operating level, the outsource partner, in close cooperation with the client, can offer ongoing savings and efficiencies in the area of energy use and consumption.

This package often includes a Combined Heat and Power (CHP) plant, also known as co-generation CHP, which is the simultaneous generation of usable heat and power (electricity) in a single process.

An overview of a CHP plant is shown in Figure 3; CHP plants are over twice as efficient as a traditional power plant. The CHP plants are built on the factory premises, electricity is sold back to both the factory and the national grid, and heat generated by the plant is then re-used in the factory.

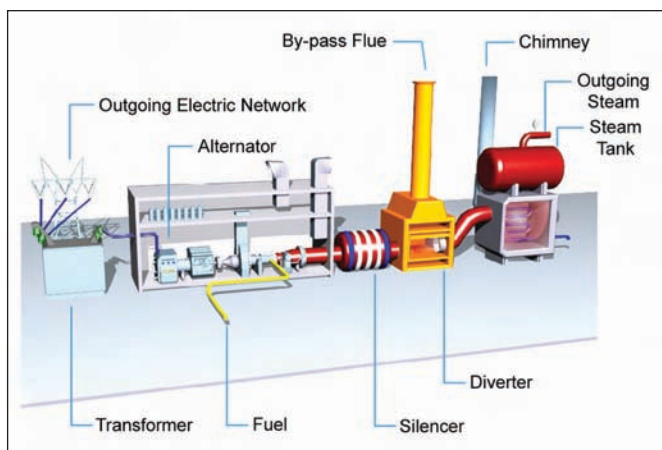

Figure 3. CHP power generation.

In 2009, a CHP is set to be constructed at the Wyeth Grange Castle plant. This project is an example of the design, build, finance, and operate/maintain model mentioned above.

## Summary and Conclusion

Following research and from the author's own experience, the area of maintenance outsourcing has been identified as a major part of modern industry. As discussed earlier, the main driver for manufacturing companies to outsource maintenance is to reduce costs and to enable them to focus on the core activity of making product, while gaining best service performance. However, this is only the baseline of possibilities – so much more can be achieved by approaching outsourcing correctly, leading to a high degree of ownership by the outsourcing partner, continuous improvement, and a win-win culture which promotes open/honest communication. The future for outsourcing is moving toward full ownership of utility systems through long-term fixed contracts that have shown clear benefits for both parties involved.

## References

1. Jones, K.E., "10 Key Indicators of Maintenance Performance," *Information Service Centre for Energy Industry*, 1999.
2. Welch, S., "A Plan for Maintenance Success," *Advanced Technology Services*, 2002.
3. Martin, H.H., "Contracting out Maintenance and a Plan for Future Research," *Journal of Quality in Maintenance Engineering*, 1997, Vol. 3, No. 2, pp. 1355 -2511.
4. Durand, A., "The Benefits of Outsourcing Maintenance," *Caribbean Business (Industrial Maintenance Supplement)*, 2003.
5. Ireland, B., "Outsourcing Options," *Electrical Contractors & Maintenance (EC&M) Magazine*, 2006.
6. Liggan, P., "The Research and Implementation of Maintenance Excellence on Clean Utility Systems in the Pharmaceutical Industry," Dublin Institute of Technology, 2008.
7. <http://www.dalkia.ie> – Combined Heat and Power Plants.

## About the Author



**Pdraig Liggan, MEng, BSc (H)**, has worked in maintenance engineering within the pharmaceutical and dairy industries for the past decade. He is currently employed with the energy and facilities management engineering company, Dalkia Ireland Ltd., where since 2003, he has been heavily involved in setting up start-up maintenance programs

at the new Wyeth, Grange Castle plant. The Wyeth plant at Grange Castle is currently one of the largest integrated Biopharmaceutical campus' in the world and is still undergoing further expansion. He can be contacted by telephone: +353-1-4648959 or by email: [ligganp@wyeth.com](mailto:ligganp@wyeth.com).

Dalkia Ireland Ltd., 145 Lakeview Drive, Airside Business Park, Swords, Co. Dublin, Eire, Ireland. 



# 2010 Facility of the Year Awards

 **Bristol-Myers Squibb**  
was a winner from  
the New Jersey Chapter.

  
was a winner from Germany.

**Genentech**  
was a winner from the Greater  
Los Angeles Chapter.

  
was a winner from China.

Will the next Facility of the Year  
Award Winner come from your  
chapter or region?

The Facility of the Year Awards program celebrates state-of-the-art pharmaceutical manufacturing projects utilizing innovative technologies to improve the quality of projects and to reduce the cost of producing high-quality medicines. Companies from 21 countries have submitted and won...the next award-winning company could be a part of your local community.

Submit an entry to the 2010 Facility of the Year Awards program and your firm may win the coveted Facility of the Year Award! Don't let your company pass up this outstanding opportunity to showcase its new or renovated facility. The program and each of the Facility of the Year Award winners will receive high-profile attention and media coverage from ISPE, INTERPHEX™, and *Pharmaceutical Processing* magazine.

**Deadline for Submissions: 2 November 2009**

For additional information about the Awards and submission procedures, visit  
[www.facilityoftheyear.org](http://www.facilityoftheyear.org).



ENGINEERING  
PHARMACEUTICAL  
INNOVATION



[www.facilityoftheyear.org](http://www.facilityoftheyear.org)

A veteran quality executive, Sharon Bleach discusses her philosophy on quality, her experience as previous chair of ISPE's International Leadership Forum, and insight into AstraZeneca's strategic approach to significant changes in the industry.

# PHARMACEUTICAL ENGINEERING Interviews

## Sharon Bleach, Vice President, Global Quality, Operations, AstraZeneca

by Rochelle Runas, ISPE Technical Writer



**Sharon Bleach** followed her degree in biophysics from Sussex University with a role in research at the Max Planck Institute in Berlin, then West Germany.

On her return to the UK, Bleach joined Wellcome's biotechnology R&D organization at Beckenham and then moved into developing deep cell culture plants in the UK, Spain, Canada, Japan, and the US. During this time, she also studied and earned her MBA from Warwick University.

Moving from R&D to Quality, Bleach led activities in a number of project and line management roles across both biotechnology and small molecule areas.

After the GlaxoWellcome merger, Bleach held quality roles covering UK and European sites. Following the merger of GlaxoWellcome and SmithKline Beecham, she became Head of Quality for European sites in eight countries, later moving on to quality associated with new product introduction in Europe, US, and Puerto Rico.

Before joining AstraZeneca in July 2008, she completed 28 years with GSK as Head of Quality Strategy, introducing a revised Quality Management System, leading Quality Training and Development and involvement in External Relations.

Bleach believes that quality is about keeping things simple, getting them right the first time, and working with motivated people who do the right things.

**Q** What are your primary responsibilities in your current position as VP, Global Quality, Operations, AstraZeneca?

**A** As a member of the leadership team for Operations, which is the manufacturing and supply operation, I am responsible for the strategy and delivery of quality activities across Operations. I have the additional role of overseeing all GxP activities throughout AstraZeneca.

**Q** What experiences and training best prepared you for your current position?

**A** Life itself! I've been very fortunate and had many different roles in my career so I have a broad experience base. I've done both site-based and corporate roles, as well as having R&D and quality experience. I've also been extremely fortunate in working with many different nationalities and cultures through the course of my career. That has provided a tremendous learning experience and opportunity to understand different things about the different cultures and countries, which is very useful in a leadership role such as this.

**Q** What are the major challenges faced by a senior quality executive in a pharmaceutical organization?

**A** I guess there's always the "not enough time in the day," which is probably typical of many senior roles in many industries. I think part of it is that regulators look on the quality organization as almost a surrogate for them in the industry, yet you're operating within a company, understanding the company perspectives and priorities. Really it's about how do you balance what regulators are expecting with the

Reprinted from  
**PHARMACEUTICAL  
ENGINEERING®**  
The Official Magazine of ISPE

July/August 2009,  
Vol. 29 No. 4

©Copyright ISPE 2009  
www.ISPE.org

company's need to be successful and, in doing all that, making sure patients get the right product when and where they need it.

**Q** Please elaborate on your philosophy, "Quality is about keeping things simple, getting them right first time, and working with motivated people who do the right things."

**A** Regulations are complex, whether you take one country, such as the US and the FDA regulations there, or whether it's Europe with the European Medicines Agency (EMA) and authorities in each member state, or whether it's Japan, Canada, Australia, etc. One of the biggest challenges is how you integrate those different requirements and how you make sure you're in line with all of those different requirements.

I also think you have to have people who want to come to work, because if they aren't enjoying what they're doing, if they don't think it's important, if they don't recognize the value that patients get from what we're doing in this industry, then you don't have the differentiator that people will keep focused. So, for me, you've got to motivate people to want to improve, to want to constantly be looking for the next idea, the good way of doing things, and how you can simplify. And the more we simplify the more of a chance we've got to get it right.

**Q** Do you think that industry and regulators are understanding that keeping things simple is the best way and is that reflected in how they're revising and coming up with regulations?

**A** I think the dialogue is much more about continuous improvement now and I don't think that people think that continuous improvement necessarily means adding complexity. Whether or not as an industry – taking regulators and suppliers together – we have focused enough on simplicity and simplification: No, I think there's more we can do there.

**Q** You've presented on ICH Q10 and been involved in the ISPE and PIC/S joint conference focusing on ICH guide-

lines in 2007, so I'm going to assume that the Quality Management System at AstraZeneca is based on Q10. Am I correct in that assumption?

**A** That's correct! I've only been at AstraZeneca since last July, but the Quality Management System is linked to Q10. However, we're also doing work on our quality system to put it into a new format and to emphasize the process thinking across the company and

around how we do that. Essentially, I think that's in line with many different companies in the industry.

**Q** Do you feel ICH guidelines are becoming part of the culture within the quality organizations of pharmaceutical companies?

**A** Yes, I think so. I think the potential benefits from ICH Q8, Q9, and Q10 are a significant opportunity for

*Continued on page 46.*

## Sterile Clean Steam Sampling



**GEMÜ BioStar®** Steam Sampler, the innovative automated sampling system for the monitoring of pure steam quality

- **Sterile from the steam pipe to the laboratory**  
 Sterilization prior to sampling, sterilized sample container, sterile sample transport
- **Automated, programmable and safe**  
 Hands-off auto sampling method eliminates potential contamination of the sample and minimizes risk of injury to operating personnel
- **Consistent, reliable and time saving**  
 Automation of the activity provides consistency and repeatability while reducing the time required to complete the sampling by plant personnel
- **Easy to install - easy to operate**  
 Simplified connections, easy plug and start, air-cooled, mobile or fixed installation, repeatable and programmed process

**GEMÜ®**

GEMÜ Gebr. Müller Apparatebau GmbH & Co. KG · Fritz-Müller-Str. 6-8 · D-74653 Ingelfingen  
 Phone +49(0)7940/123-0 · Telefax +49(0)7940/123-224 · info@gemue.de · www.gemue.de

industry and regulators. So, it would be shortsighted, perhaps, of companies to ignore the opportunities that are there. You can either say, "Well, we'll start by working on these things now and it may not be perfect, but we'll improve as we go on," or you can say, "We'll hang back and wait and see how it works." We've decided we're going to be in the forefront of this because we think there are some significant benefits and I know there are a number of companies that are doing exactly the same thing.

**Q** Your career has encompassed positions in R&D and quality. Did your experiences in R&D help you bring different perspectives to positions you've held in Quality? What are those perspectives?

**A** When you're in R&D you learn very clearly: You only ever make one change at a time in an experiment otherwise you don't know what impact it's had. And that lesson, I think, has stood me in good stead when going through a lot of quality changes and initiatives. If you make multiple changes at the same time, you have no idea which ones have any impact.

I think in general, it is about understanding the whole product development lifecycle. Understanding the early stages and how you work some of those things through is helpful in terms of looking at the lifecycle management of products and what you need to think about at different stages.

I also think it's valuable not to think of there being some big brick or glass wall between R&D and manufacturing organizations, because the skill sets are very transferable between the different areas. I think it's great to be able to encourage people to move between different parts of a business to see those different perspectives.

**Q** What was your experience like as previous Chair of ISPE's International Leadership Forum (ILF)?

**A** I thought it was a tremendous opportunity and really enjoyed doing it. It was great to have the opportunity to actively shape where ILF went for a period. We set up some different work

teams, which enabled us to have some energy from ILF Members focused on the key topics that were of concern to industry and to regulators.

**Q** What are some of those key topics?

**A** One of our major pieces of work is around supply chain security and teams looking at what industry can do to more actively engage with supply chain security initiatives that regulators are highlighting they're particularly concerned about. And obviously it came a lot from the discussion around contaminated milk, or melanin, or the Heparin situation.

We had a very good discussion about 18 months ago with some of the regulators who basically said, "Look, this is our top priority." It was really satisfying to be able to say to the regulators, "Actually, the ILF has already discussed this and we've got a piece of work we are going to be undertaking that you're welcome to be part of and provide us with input and we'll have dialogue with you about what we're doing." The next step will be during this year's Washington Conference with a seminar on Supply Chain Integrity and Anti-Counterfeiting.

**Q** In your opinion, what have been the significant changes in the industry in the past decade and what are the challenges for the future?

**A** One of the big challenges over the past decade has been that the industry as a whole seems to have moved from being perceived as adding value and doing the right thing for patients and people around the world, to being an industry that is not valued in the same way at all. That image and reputation shift and damage is really unfortunate because the majority of people in this industry are here to do the right thing for patients and to make a positive difference to peoples' lives.

The other thing is the consolidation that's going on in the industry at the moment. Companies across the industry understand that the future is going to be very different, and that we all have to approach our response to

these changes in the best way we can. At AZ we are seeking more partnerships and collaborations, as well as driving down our operating costs as much as we can without compromising our quality focus, to ensure our approach to drug development is cost effective, as well as being sensitive to the unmet needs of patients.

**Q** In light of these challenging economic times, some predict that pharmaceutical companies will build themselves horizontally rather than vertically with outsourcing playing a bigger role in that change. In your experience with different companies and certainly now, are you seeing this happen?

**A** Yes. We're actively outsourcing some activities, where the activity is not core and we think another organization can do it in a more effective way, and actively consolidating in house for others that we see as a core strength for us. The key is to maintain great quality and a focus on delivering great medicines for patients.

**Q** In what ways do you believe a global organization such as ISPE can assist regulators, pharmaceutical companies, and individuals in the international arena?

**A** I think one of the greatest opportunities for ISPE is that it provides a whole series of different forums for discussion between regulators and industry and individuals as peers. You can have very good dialogue about the challenges that face the industry either at a high level and global picture, or you can take it down to an extremely detailed technical level and make sure that we've got a common, good understanding of good ways of addressing a technical issue. And it's that breadth in terms of the range of people who are involved, the range of issues, and the levels of the dialogue that can take place.

**Q** Coming from a biotechnology background, what technological and operational breakthroughs do you anticipate within the next five years?

**A** First, I'd say that my direct biotech experience was quite a long time ago. I think one of the things about biotech is that it's been a long time coming and we're still not quite there yet. We'll see more biotech products coming through as there is a greater push for more complex medicines that respond to those areas where there is unmet medical need. But that will be balanced by the pressure on healthcare budgets and the cost of developing these biological medicines, which are more complex and therefore cost more to deliver.

**Q** What has been your most fulfilling role so far in your career?

**A** Well of course the one I'm in now, because it really brings together a lot of the points I learned, the skills and experiences that I've picked up along the way. It's great to be able to work in a global role with many different countries and different groups internally. Also, I find it really good to be able to work externally. I think it's a

really good challenge for the company to make sure that you don't just have an internal perspective. You need to keep an eye on what's going on in the external environment and challenge yourself all the time with that. This role is great and I'm thoroughly enjoying it.

**Q** What kind of career advice can you offer to our readers who are pursuing careers in quality?

**A** I think quality provides a great grounding and a great way into the industry. There are technical skills that people can learn which they can apply to multiple other roles in the industry. The thinking in a quality group is a good education and helpful in terms of looking at different perspectives.

I also think there should be a very dynamic flow with people coming through quality as part of a career or part of an education process and into other roles. So it's a two way flow in and out of quality. Some will be there all their careers, some will spend only a short while there; both are perfectly valid.

I think that quality organization has a real opportunity always to shape how a business is working, to add value to the business. I think in the past people used to see quality, at best as a necessary cost, and at worst as an unnecessary encumbrance. Today, it is considered much more of an opportunity to add value to product flow and to corporate reputation.

**Q** What kind of activities do you enjoy in your free time?

**A** I love spending time with family and friends. I love to garden, to sit and read, and to have a good glass of wine.

I also enjoy traveling with my family; we are planning a trip to Jordan later in the year to see Petra, the Dead Sea, and Wadi Rum. I have to get really fit for that I'm told, because my daughter has grand plans about climbing up huge numbers of steps in Petra to get good views! 

## IMA, the expert in containment process



all O.E.B. categories.

**MORE THAN 60 DIFFERENT INSTALLATIONS WORLDWIDE** for dispensing, handling, granulating, tableting, capsule filling and coating of category IV and V products, both for production and R&D applications.

- Customized solutions.
- Isolated processing areas on all machines due to special sealing systems.
- Isolation at product loading and exit due to isolators and high containment valves.
- Possibility to install in-line indirect methods to control the high containment manufacturing process.
- Special solutions for the treatment of air exhausted from the processing area and dust extracted from the machines during production.
- Clean In Place systems.

**IMA ACTIVE Division**  
mktg.soliddose@ima.it • www.ima.it

**IMA NORTH AMERICA, INC.**  
sales@imausa.net • www.imanorthamerica.com

**IMA**  **ACTIVE**  
Solid Dose Solutions

HANDLING • GRANULATION • TABLETING • CAPSULE FILLING AND BANDING • WEIGHT CHECKING • COATING • WASHING



This article presents the outcome of a series of workshops on the effects of rouging in pharmaceutical water and steam systems.

## Rouge in Pharmaceutical Water and Steam Systems

by ISPE Critical Utilities D/A/CH COP

### Introduction

The ISPE Critical Utilities D/A/CH COP held a series of workshops on pharmaceutical water and steam. The discussions focused on three aspects of rouge, including:

- Choice of materials, quality control
- Engineering, system design
- Service and maintenance

Fifty experts participated in the workshops with a range of experience in various fields, including OEM, engineering, material production, instrument manufacturing, consulting, QC, and pharmaceutical manufacturing.

### Choice of Materials, QC-Service System Startup

The desired condition for new systems (zero or initial-state) should be well defined.

- Sufficiently detailed specifications should be available for all components (material, surface roughness, and tolerances) and these should be tested during the qualification phase. The thermal and chemical resistance also should be checked. Furthermore, special care should be taken regarding the cleanliness of all components from the time of delivery onward.
- If possible (cost feasibility), the materials for pipes, fittings, and valves should be the same to avoid different behavior (welding).

### Definition of "Treatment"

At the end of the installation phase, the entire assembly must be dry.

The following methods are considered treatments:

- Removal of any installation debris, i.e., using compressed air, degreasing, etc.

- Pickling, passivation, rinsing

Each method should be executed, tested, and documented in accordance with a Standard Operating Procedure (SOP). The SOP can be created with the support of the expert/qualified company. The responsibility for the execution should be defined in the SOP.

### Methods

#### Compressed air

- Removal of large debris
- Check for blockage

#### Rinsing

- Rinsing is used to remove:
  - Loose debris or water soluble substances
  - Detergents, etc.
- Rinse after each treatment step.
- The water quality for each rinse step should be defined individually. Purified Water (PW) is usually sufficient.
- The PW should have a pH of five to seven at the end of the rinsing cycle.

#### Degreasing with Alkaline Detergents

- Removal of debris
- Wash out fatty or oily substances

#### Chemical Cleaning/Pickling

- The makeup of the chemical solution should be suitable for the surface roughness of the system (qualified SOP).
- Removal of contaminants (nonalloyed ferrous components, shavings (alloy and nonalloy), construction dust, discoloration, etc.)
- In special cases, such as surface damage, removal by chemical reaction (erosive)
- Electro polished systems, if pickled, are pickled without material removal (see following comments).

#### "Pickling:"

Pickling (cleaning) with weak acids (citric acid,

Reprinted from  
**PHARMACEUTICAL  
ENGINEERING®**  
The Official Magazine of ISPE

July/August 2009,  
Vol. 29 No.4

©Copyright ISPE 2009  
www.ISPE.org

phosphoric acid) dissolve just surface contamination without damaging the material. The passive layer remains intact. Erosive pickling only takes place using reducing acids or acid mixtures, such as nitric acid or nitric and hydrofluoric acid mixtures and results in the chemical removal of the passive layer. This is usually not necessary for the pharmaceutical industry.

In general, the comments regarding erosive and non-erosive pickling are necessary because pickling always removes something. A film or discoloring could be seen, but are removed during pickling, revealing the layer below.

## Passivation

- The passive layer is always present in a neutral, water based system at ambient temperatures, even at atmospheric exposure with air (oxygen environments, chemical equilibrium).
- The stability and homogeneity of the passive layer is dependent on the redox potential.
  - An oxygen supply is necessary for an optimal redox potential.
  - A low pH is unfavorable. Since CO<sub>2</sub> reduces the pH value, its concentration should be minimized.

## Developing the Passive Layer

- The presence of O<sub>2</sub> or other oxidizing agents, such as ozone, supports the development of the passive layer.
- The passive layer can be artificially developed with chemical treatment. The results of such a treatment are only temporary and not permanent. In time, the system will return to the equilibrium state dictated by the redox system.

## Testing the Passive Layer (Thickness)

- The passive layer doesn't normally need to be tested since it is naturally present.
- There is no regulatory requirement to test the passive layer.
- The thickness of the passive layer is dependant on the surrounding conditions; therefore, varies according to the conditions in the pipe (for example, if the pipe is filled with liquid or air). Due to this variability, testing the thickness of the passive layer only gives information on the state of the layer at the time of the testing.
- Possible measuring methods can be conducted by qualified experts. Laboratory tests (destructive testing), such as X-ray photoelectron spectroscopy, are time consuming and expensive.
- Non-destructive online measurements, which characterize the condition of the material, have been proven in the chemical industry. These are indirect measurements, using sensors made of the same material, which are evaluated using complex algorithms.

## Final Rinse

- With *water for injection, highly purified water, or purified water* the minimum required water quality should be defined (potential cost savings). This quality should be at least equal to the operating medium. For instance, if WFI

is required for the production, then the final rinse should be conducted using WFI.

## Handover Criteria

- The success of the rinse should be proven using suitable acceptance criteria, for instance, conductivity and TOC are frequently used. The tolerance range should correspond to the same predefined range as the rinsing water.
- Visual control at accessible points or with video endoscope can be used to ensure that no installation debris (non-suspended particles) has been left behind.

## Measures for Existing Installations

The system components for existing installations should have documented specifications. If this isn't the case, then the current state of the system components should be documented through a detailed system analysis. At least the following aspects should be considered as adapted treatment methods or processes may be required:

- Material qualities
  - Corrosion resistance is dependant on these characteristics. Therefore, if rouging is corrosion, it follows that the material quality influences the rouging tendency.
- Surface condition (surface roughness, visual evaluation of the surface condition, type and extent of the rouging)

*Continued on page 50.*

[www.ISPE.org/innovationshowcase](http://www.ISPE.org/innovationshowcase)

Register today!

## ISPE Facility of the Year: Innovation Showcase

**2-3 November**

Ulm, Germany

Learn about the latest state-of-the-art developments being implemented by manufacturers in the region.

- Seminar on innovation in pharmaceutical engineering and manufacturing
- Case studies on innovation presented by recent Facility of the Year Awards winners
- Background on projects
- Q&A sessions
- Networking reception
- Site visits to award-winning sites

ENGINEERING PHARMACEUTICAL INNOVATION



Sponsorship and Table Top Exhibit Opportunities Available

- Safety aspects, such as solid connections rather than flexible tubing
- Disposal of treatment and rinsing solutions

System analysis and evaluation should regularly take place using existing monitoring results.

## *Definition of Treatment*

If the system analysis shows a need to take action, suitable treatment methods from the list above should be used.

## **Measures for Derouging**

### *De-rouging of Existing Installations*

The derouging method should be conducted, tested, and documented in accordance with a Standard Operating Procedure (SOP). If necessary, existing warranty conditions should be taken into consideration.

- The SOP can be developed with qualified experts.
- The responsibility for the execution should be decided in advance.

*The recipe* should be based on the following:

- Current state (see above)
- Suitability tests (effectiveness) should influence the choice of the process.

*The frequency* of derouging should be based on the following criteria:

- In accordance with monitoring results (months, years)
- In accordance with experience and knowledge of the installation
- Dependent on the state

*Testing* and documentation can be assigned to the contracting company.

- Visual inspection in accordance with agreed acceptance criteria (colors, film, etc.)
- Wipe test
- Photos, etc.

## **Choice of Materials and Processing/Machining**

The choice of materials influences the formation of rouging.

### **Plastics**

#### Pros:

- No rouging because it is a nonmetallic material

#### Cons:

- Thermal deformation from variance in temperature (hot operation or sanitization)
- New design of piping supports (high expansion value)
- Aging stability (hot sanitizations)
- Not always feasible for hot systems. Pressure and vacuum

tolerances must be observed, regarding the piping connections.

- Mix of materials – for instance, a stainless steel tank, piping in PVDF. A rouging layer can be transported onto the plastic surfaces.
- The chemical tolerance of PVDF is limited to a maximum of pH 12 (relevant for treatment chemicals).

### **Metal Alloys**

The austenitic stainless steels used most frequently in the pharmaceutical industry are 1.4404/1.4435 (316L), 1.4571 (316Ti).

#### Pros:

- They can be used for cold and hot media. Almost all components are available in these materials.

#### Cons:

- Stainless steel is susceptible to rouging.

#### *Specific characteristics of individual alloys:*

- 1.4404 – somewhat less Mo (0.5%), slightly reduced corrosion resistance in hot systems. Good availability (tubing, fittings, instruments, valves, etc.)
- 1.4435 – limited availability of fittings and instruments. Expensive material. Also susceptible to rouging.

Other alloys also are possible; however, they may be more difficult to procure and are significantly more expensive.

1.4539, 1.4462 (Ferritic-Austenitic Duplexsteel), Ni-Basic-Alloy, Alloy 33 (high content of chromium), Titanium.

#### Pros:

- These special materials could be more resistance to rouging; however, this has not been proven yet.
- 1.4462 is resistant to rouging for a wide redox range in pure water systems, but doesn't solve all problems.
- Optimizing the passive layer through higher chromium content. The Alloy 33 with 33% Cr shows a chromium content in the passive layer of 83% after exposure to 95°C pure water.
- No experience with Nickel based alloys. Rouging has been observed with Hastelloy C-276, which is not surprising considering the lower Cr content.
- Titanium stabilized materials: valves and regulating valves in WFI systems are often made of 316Ti.

#### Cons:

- Due to cost and availability, 1.4539 und 1.4462 are only used in special cases.

### **Delta Ferrite Content**

- The delta ferrite criteria can be traced back to the BN 2 (Basler Norm, a guideline of the Swiss Chemical and Pharmaceutical Industries), where a very low delta ferrite content of 0.5% is defined. The original intention of BN2 was to just take the delta ferrite content into account. The delta ferrite limit was specified as a preventive measure and is not based on scientific proof. The limit is too strict and is not practical. It dictates the use of steel, which is considerably more expensive and compliant welds are

considerably more difficult to achieve.

- Many of the participants have found that 3% is a more feasible limit. Since several participants also have had positive experience with considerably higher delta ferrite levels (no unusual rouging observed), 5% was suggested as the maximum for a preventive measure. It should be noted that calling 5% a preventive measure against rouging is not quite correct as lower delta ferrite levels won't have a negative effect on rouging, but could drive up the material costs.
- The goal (specification) should be 3%. Specifying < 3% is not recommended based on the experience of the group. An absolute maximum value of 5% should not be exceeded.
- A complete lack of iron can result in a significantly higher susceptibility to heat cracks and require the use of special weld filler metal.
- This aspect is overvalued regarding its potential negative influence on rouging. The delta ferrite has a more elevated Cr content and is fundamentally more resistant to rouging than austenitic (bulk) structure.
- This does not protect against rouging!
- The limit for delta ferrite was created as a measure of corrosion resistance and it can be used as proof of weld quality. The delta ferrite measurement is an economical and useful method to test weld quality if the weld filler material is fully alloyed.
- The delta ferrite content does not have an effect on the prevention of rouging.

## Surface Quality

*Stainless steel is always produced with a specific surface quality. The many variations, which are common for piping, are well defined in industry standards. There also are standards which described terms and conditions for delivery.*

### Common Design:

- Seamless tubing or longitudinal welds
- Mechanically polished or honed (bright finish, bright rolled, and cold drawn)
- Not pickled, just rinsed with water

### Pros:

- More economical than electro polished tube

### Cons:

- These surface qualities are often treated in situ. *With the exception Ti or Nb stabilized steel, all steel is available with electro polished surfaces, which can lead to further improvement*
- A roughness of Ra < 0.8 µm should be specified

### Pros:

- Due to the reduced surface area and the more compact, clean (free from defects) passive layer in comparison to non electropolished surfaces, electro polished surfaces generally show less tendency to rouging.

*Continued on page 52.*



## Pharmaceutical Online Is The Online Industry Standard



### Visit The NEW Pharmaceutical Online

An improved Pharmaceutical Online is now live, putting the latest technical, operational, and regulatory information about the global pharmaceutical development and production industry at your fingertips. A host of new features makes it easier than ever before to find exactly what you need, whether it's product overviews, industry news, technical articles, or anything else related to the field. Visit us at [www.pharmaceuticalonline.com](http://www.pharmaceuticalonline.com).

### Join the community and benefit from...

#### Rich Content

- Latest news and groundbreaking research
- Technical articles, case studies, and white papers
- Product, service, and solution information
- Video demonstrations, datasheets, and other free downloads

#### Site Resources

- Locating and sourcing products and services
- Keeping up with industry trends
- Interacting and collaborating with your peers

#### Free Newsletter

- Delivered every Tuesday and Thursday straight to your Inbox

Join the community today at [www.pharmaceuticalonline.com/signup](http://www.pharmaceuticalonline.com/signup)

- Better cleanability with higher surface quality

## Cons:

- Treatment with strong acids roughens the surface.
- Special care must be taken if any secondary welding is required.
- The welds in the pipe system can influence the surface quality.

## Welding Procedures

The Processing of the materials should be clearly defined, while taking into account the following criteria:

- Goods-in quality control (QM, QS, documentation)
- Storage conditions and environment (low dust) should be specified

### A. Weld Preparation

- Cutting of non alloyed ferritic materials → these develop very aggressive particles.
- Cutting of alloyed materials leads to conversion to martensite (magnetic, less corrosion resistant).
- Do not use a cutting disc, grinder.

### B. Welding Procedure

- Define welding procedure in advance (orbital or manual)
- Develop and qualify site specific welding procedures
- Welder's qualifications should correlate to the qualified welding procedures (see above)
- Automatic welding procedures (MIG, WIG)
- Laser, plasma welding procedures (tanks, etc.)
- Manual welds allowed as exceptions

### C. Weld Filler Metal

The corrosion resistance is improved when higher alloyed filler metal in comparison to the welded material is used. This also helps maintain a low delta ferrite content (experience: of the same kind as basic material).

### D. Weld Testing and Documentation

- All welds should be visually examined (naked eye, endoscope). A predetermined percentage of the welds should be documented with photos, DVD, or video.
- Examination of the weld formation and any discoloration should be included.
- An alternate testing method should be set for welds, which can not be visually examined (X-ray, sample weld before and after the true welding, etc.).

Further Documentation:

- Risk analysis, sample welds
- Weld plan, weld supervision, work instructions, welding procedure qualification
- Welder qualification
- "Technische Regel TR 153, "Gütesicherung von Schweißnähten an Apparaten und Rohrleitungen" issued by the Basel Chemical Industry (BCI). Available in German only.

## Engineering, System Design

### Influencing Factors

*How can rouging be avoided through engineering and system design of the water treatment plant?*

Various aspects under consideration of possible influencing factors, such as the design itself and monitoring, should be considered.

The following factors, which all could possibly effect the development of rouging, were considered in the workshop:

1. CO<sub>2</sub>
2. Temperature
3. Nitrogen
4. Oxygen
5. Particle Carryover
6. Ozone
7. Feedwater
8. Choice of Materials
9. Sanitization Process

#### 1. CO<sub>2</sub>

Elevated CO<sub>2</sub> concentrations cause a decrease in pH. This can lead to destabilization of the passive layer, particularly in hot systems (80°C).

#### 2. Temperature

Since rouging is a form of corrosion, it is expected that there is a system specific temperature above which the rouging will increase with further temperature increase.

#### 3. Nitrogen

Nitrogen blanketing of storage tanks removes the presence of oxygen in the tank atmosphere. This leads to a drop in the oxygen concentration of the water, reducing the redox potential, which results in a change in the passive layer.

#### 4. Oxygen

Oxygen facilitates the natural continuous re-passivation of the steel surface.

#### 5. Particle Carryover

Possible particle carryover from the water purification equipment or WFI still into the distribution system can be avoided or minimized through proper design.

- For example: by avoiding the use of non-alloyed steels for construction or piping material as well as through appropriate operating conditions.
- Further measures can only be defined once the possible formation mechanisms for ferrous compounds have been fully identified.

It is assumed that semi- intermediate- and final products (bulk) will pass particle filtration steps during the production process.

## 6. Ozone

Ozone, frequently used in cold storage and distribution systems, is thought to favorably effect the formation of the passive layer on the steel surface. However, ozone concentrations over about 1 ppm can lead to corrosion when chlorides are present and standard alloys, such as AISI 304 and 316 are used.

## 7. Feed Water

A detailed examination of the feed water quality is necessary during the equipment engineering phase to identify possible corrosion sources.

The goal is to eliminate iron, manganese, silica, CO<sub>2</sub>, and chlorides.

## 8. Choice of Materials

The choice of materials is handled in detail under "Choice of materials, QC."

## 9. Sanitization Process

Since high temperatures support corrosion, the temperature in a given system should be kept as low as possible without compromising safe operation. Frequent steam or hot water sanitizations could support rouge formation with the temperature and time being the deciding factors. Reasonable sanitization intervals should be set based on monitoring results (qualification phase, performance qualification, routine).

## Design

The following design criteria should be critically analyzed as part of a risk analysis. The focus should be on the effects on the equipment itself, on the operation of the equipment, and on the product.

- Sanitization and Cleanability
  - Drainability
  - Rinsable pure steam piping, for example, design the condensate piping system in a way in which it can be used to provide circulation during future chemical treatments (passivation, de-rouging).
  - Optimization of the cleaning procedure to simplify and reduce the amount of cleaning agent needed
- Allow for removable inspection spool pieces in the piping
  - Installation of easy to access spool pieces, such as elbows or bends at reference points in the piping system where rouging is expected
  - These pieces should be easily replaceable to allow detailed analysis with destructive testing in the lab when necessary.
- Demisters in the form of wire mesh should be avoided when possible, due to their large surface areas. Cyclone separators are acceptable.
- Welds are seen as a risk factor.
 

Correctly welded seams using WIG-process and with sufficient weld seam protection (inert gas shielded) do not add to the corrosion risk.

  - Cold bending offers a possibility to reduce the number of welds in a system, particularly for smaller pipe diameters (i.e., up to DN25).

- The material is more susceptible to local corrosion depending on the degree of cold forming; however, this isn't relevant for high purity water systems.
- Bending pipework is often preferred, due to economic reasons.
- CO<sub>2</sub> elimination
  - Protecting WFI stills and pure steam generators by installing selective degassing steps upstream
  - CO<sub>2</sub> traps can be installed on the product water storage tanks to prevent CO<sub>2</sub> from entering the distribution system. The CO<sub>2</sub> trap shouldn't be allowed to collect moisture as this can cause blockage.

## Monitoring

- Visual inspection using sight glasses, inspection pieces, or opening the pump housing
- Inline measurement
  - Direct quantitative measurement of rouge is not commercially available. Such monitoring technologies are currently in development.
- Other parameters and measurements
  - Measuring methods for parameters, such as pH, particle quantification and size, and CO<sub>2</sub> concentration are available. Their influence on rouging has not been conclusively studied or proven.

## Service and Maintenance

### Suggested Procedure

A risk analysis is a valuable starting point for the selection or determination of measures, which are to be implemented in the service and maintenance plan. The experience of the operator as well as the previous actions of the engineering or maintenance and quality control departments also should be taken into account.

The risk analysis should work out which parts of the system are critical and define the necessary treatment (to what extent, in which intervals, to which time point, and with which measures).

Figure 1 shows a possible procedure for the development of a plant specific service and maintenance plan.

It is generally accepted that suspended particles in low concentrations can be present and will be removed at filters.

The usual sample methods based on the Pharmacopeia will usually not discover the presence of particles.

The current findings show no influence of rouging on the mechanical stability of piping and components. It seems prudent to involve all parties, for instance, operator, quality control, engineering, and maintenance in the risk analysis process. Some of the issues and problems which they will address are:

- What are the possible effects on the product? Is it an API, end product?
- Can dissolved metallic ions occur (such as ferric ions) and what influence would this have on the product?
- Can adherent metal hydroxides occur (Fe-, Ni-, Cr-) and what influence would this have on the product?

*Continued on page 54.*

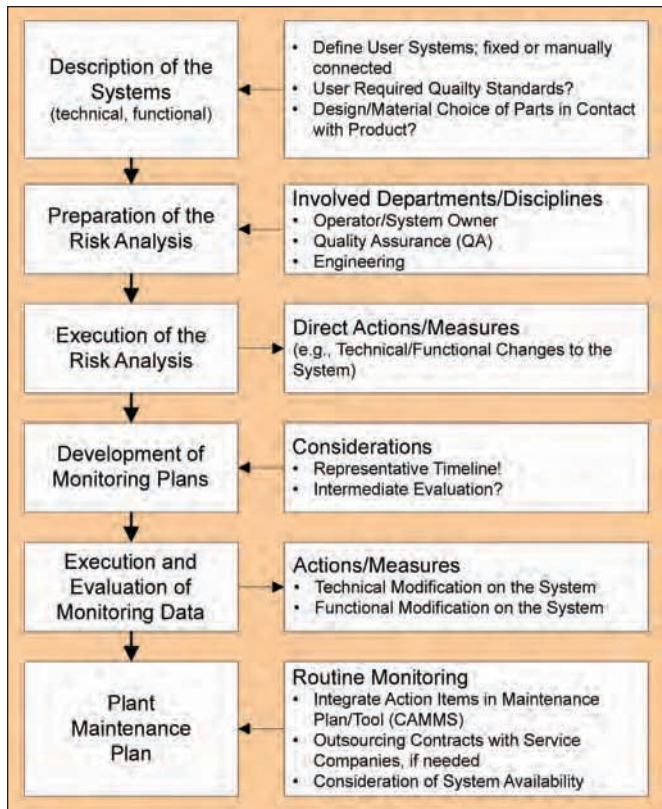

Figure 1. Flow chart risk analysis.

- Are filters in place which would be negatively impacted by particles?
- Can deposits form on measuring probes and sensors?
- If rouging occurs, could it negatively impact downstream plants or equipment?
- Are heat exchangers present and could these be negatively impacted?
- Are components, such as injectors, present whose function would be negatively impacted by the presence of particles?
- Further critical parts could be: pumps, instrument ports, tanks, valves, spray balls, forged components, vacuum molded components.
- Are unplanned events expected whose frequency would influence the availability of a plant, for example, when a cause analysis and subsequent service and maintenance measures are necessary after an OOS finding?
- Are measures to restore the defined state necessary after repairs or planned expansions or changes to the system, such as rinsing, passivation, pickling etc., after welding work has been done?
- Could the surface finish be changed by deposits? Will this favor biofilm formation?

## Inspection Program

A periodic monitoring program should be established to provide regular controls at the critical points of the system, which were defined in the risk analysis, to collect experience and information, for instance, through photo documentation. This provides the basis for the service and maintenance plan.

Both on and off-line tests can be used as well as testing the surface of spool pieces removed from the system.

An inspection plan can be created in order to collect enough information and empirical test results to allow optimization.

The following inspection and evaluation methods can be defined and used primarily:

- General visual inspection, e.g., through an inspection glass or with endoscope
  - Possible assessment: color (yellow, orange, red, brown, etc.) or surface finish (dull, shiny, morbid)
- Swab test (results: particles are removable, partly removable, not removable)
- Optical inline measurement
- Particle measurement, online/inline
- Filter: the water is filtered offline at 0.1  $\mu\text{m}$  and the filter membrane then undergoes laboratory analysis and evaluation, for instance, checking if discoloration or particles are present. This type of test should be carried out at predetermined intervals and the test results should influence the testing intervals.
- Inspection spool pieces: the following should be taken into account:
  - The piece should be representative of the system in terms of surface finish, material, etc.
  - Critical points in the system
  - They do not necessarily need to be built into straight piping segments.
  - It is better to use pieces with elbows, valves, or instruments. Procedure and use of spool pieces:
    - The spool piece is removed during maintenance and is used as a reference which is used as a sample for testing different cleaning methods.
- Electro-chemical methods

Monitoring data can be regularly evaluated on the basis of the monitoring plan. The results are used defining objective acceptance criteria and specifying the required state of the system.

## Maintenance Plan

One of the most important goals for evaluating the inspection results is their further use toward development of a system specific maintenance plan.

All results from the inspection, particularly from the spool pieces, should be taken into account in the development of the plan and in determining the steps which are to be taken. Depending on the actual situation, the plan can contain the following points and actions to be taken:

- location of the inspection or actions to be taken
- responsibility
- frequency or interval of the inspection or execution of the actions to be taken
- experience from previous cleanings, when available
- execution of a cleaning procedure, when necessary

- For especially critical cases in clean steam systems, a particle filter can be installed at the point of use. For this application, a filter size of  $< 0.1 \mu\text{m}$  is generally acceptable.
- Carbon dioxide absorbers can be used, for instance, on water storage tanks.

If the decision has been made that cleaning is necessary, the following issues should be decided, where appropriate:

- Should a general chemical clean take place?
- choice of the cleaning media (anodic clean, electro polishing)
- definition of success factors, using monitoring methods, such as conductivity, inspection spools etc., or use of passive layer measuring device, Ferroxyl test (ASTM-A380)
- definition of cycles and time periods, dependent on process
- In the case of older systems, special attention should be placed when defining parameters to take into account design, material, and components.

The operator must ensure that the following is met:

- Execution description exists and is accepted.
- Critical parameters, such as the treatment temperature and soak time are defined.
- The execution is properly documented.
- The scope of documentation is defined.
- The execution and scope of evaluating if the treatment was a success is defined.
- Procedure or maintenance plan is approved.

### Regulatory Aspects

In order to ensure that the current regulatory requirements are understood, it is advisable to keep up to date on the available audit information (FDA Warning Letters) as well as literature and publications.

Should the regulatory agency check how rouging is handled, it should be possible to present and explain how the procedure defining the maintenance and inspection plan was conducted as well as the results.

The operator must ensure that cleaning (derouging), monitoring, etc. is documented. In particular, a treatment report should be available which documents the results (also with photos) and in which all relevant points are systematically addressed.

### About the Authors

The Critical Utilities D/A/CH is a local ISPE Community of Practice (COP) comprised of individuals from Germany/Austria/Switzerland with expertise in pharmaceutical water and steam. 

Visit the Critical Utilities (CU) COP on the ISPE Web site for discussions on other related topics ---  
<http://www.ispe.org/communitiesofpractice>



Your Single Source Solution Provider

## Director Series Reactor Temperature Control Module



### Features Include:

- ❖ Temperature Range from  $-80^{\circ}$  to  $+285^{\circ}\text{C}$
- ❖ Stainless Steel Construction
- ❖ Sizes from 20 Liter to 500 Gallon Reactors
- ❖ Jacket Delivery Pressure Control
- ❖ Single Loop or Cascade Control
- ❖ General Duty or Explosion Proof Classification
- ❖ PLC Control, Data Logging & Trending Software, Self Tuning for Accuracy  $\pm 1^{\circ}\text{C}$

Budzar Industries has specialized in process fluid heat transfer systems since 1975 and has earned a global reputation for quality and ingenuity in the design, engineering, and manufacturing of temperature control systems. Budzar Industries systems are found throughout the world, delivering accurate temperature measurement and control to the production of pharmaceuticals, chemicals, petroleum, rubber, power, steel, food, and plastics.

### Budzar Industries

38241 Willoughby Parkway  
Willoughby, Ohio 44094  
440-918-0505 • [www.Budzar.com](http://www.Budzar.com)



## Europe

### Denmark

#### *Defects Medicines – Packaging<sup>1</sup>*

The annual report on product defects and recalls for 2008 covering both marketed and non-marketed medicines was published by the Danish Medicines Agency. This report showed most of the recalls were issued because of wrapping defects. Reports on the lack of adherence to good manufacturing practice regulations also were sent to the agency as a result of inspections carried out by various European medicines agencies.

The most current defect reported was regarding packaging. Most of the defects were related to packaging or repackaging processes and to wrapping – usually plastic – and mainly concerned the printing of incorrect expiry dates on packaging.

Only five side effects related to product defects were reported in the 177 reports filed with the agency.

### United Kingdom

#### *Notifying the GLPMA of Changes within a GLP Test Facility<sup>2</sup>*

In April 2009, the Good Laboratory Practice Monitoring Authority (GLPMA) released a guidance advising manufacturers about the declaration form to the GLPMA that needs to be filled out when there are changes made within a GLP test facility. This GLP TEST FACILITY form was part of the risk assessment process settled by the GLPMA in order to ensure public safety and compliance with the Good Laboratory Practices (GLP) standards. Changes to be notified to the GLPMA will be the volume of GLP work undertaken, types of GLP activities undertaken, contracting out of GLP functions, facilities and equipment, personnel aspects and other changes such as changes in company ownership or changes to the management or organization structure.

#### *GMP – Update to Labeling Requirements for Pandemic Antivirals<sup>3</sup>*

The Manufacturing and Wholesale

Dealing Regulations SI 2005 No 2789 was replaced by the regulation SI 2009 No 1164 in May 2009.

Amendments have been made which affect the labelling requirements for antiviral medicines for children under the age of one year in a pandemic situation, allow for notice of urgent safety measures to be given as soon as possible to the licensing authority and an ethics committee during a period in which a disease is pandemic and is a serious risk to human health, and enable the wholesale distribution of unauthorised medicinal products in response to the suspected or confirmed spread of health-harming substances.

The regulation came into force on 8 May 2009.

#### *EudraGMP Database<sup>4</sup>*

The Medicines and Healthcare products Regulatory Agency (MHRA) implemented a new system that will automatically transfer data from its medicines database Sentinel onto the European database EudraGMP launched in 2007 and maintained by the European Medicines Agency.<sup>1</sup> The EudraGMP database was launched in order to facilitate the exchange of information on compliance with good manufacturing practice.

Information on manufacturing and importation authorisations and post-inspection good manufacturing practice certificates issued by the MHRA will be automatically published on the EudraGMP.

The MHRA Director of Information Alison Davis said this system will ensure the information in EudraGMP remains current while reducing the burden of data transfer.

### Turkey

#### *GMP<sup>5</sup>*

The GMP guideline was revised in accordance with the EMEA and ICH Guidelines and the specific conditions in Turkey. It was approved and published on 11 May 2009. During inspections performed by the MoH, the manufacturers of pharmaceutical preparations and active ingredients will be required to comply with provisions of this Guideline.

## International

### ASEAN Countries

#### *GMP Inspection Reports<sup>6</sup>*

In April at the Pattaya summit in Thailand, a mutual recognition agreement was signed by 10 ASEAN countries agreeing to recognise certifications and/or inspection reports on good manufacturing practice of pharmaceutical companies within the region.

All ASEAN member states are expected to fully implement this mutual recognition agreement by the 1st January 2011 and the GMP certificates and reports will be used as the basis granting approvals, delivering licenses to the manufacturer, supporting post market assessments of conformity for products and providing information on manufacturer facilities or testing laboratories in the ASEAN region.

In this agreement, the format that drug regulatory authorities will have to follow when issuing the GMP inspection reports is specified. Information on the dosage forms manufactured at the facility and manufacturer compliance with the GMP requirements will be captured in inspection reports.

Under this agreement, where a manufacturing facility has not been inspected recently, a Member state can request its counterpart to carry out a specific and detailed inspection. The aim of this GMP mutual recognition agreement is to move closer to its 2015 goal of a single Southeast Asian market. The agreement will help to ensure the safety, quality and efficacy of medicinal products manufactured in the region.

Consumers will benefit from greater confidence in the safety of medicines being sold and the business costs of manufacturers will be lowered by the mutual recognition of inspection reports as they will not be required to undergo a repeated testing or certification process for marketing their products in the different member states.

### Brazil

#### *Manufacturing Resolutions for Influenza A Vaccines (H1N1)<sup>7</sup>*

The National Health Surveillance Agency (ANVISA) issued on 7 May 2009 the Resolution RDC 18 for Manufactur-

ers of influenza A vaccines (H1N1) in Brazil.

This resolution states that the manufacturing of influenza A vaccines (H1N1) in Brazil will be previously authorized in Brazil provided that the following requirements are fulfilled:

- manufacturers hold a Marketing Authorization granted by ANVISA for manufacturing seasonal influenza A vaccines
- manufacturing takes place in sites authorized by ANVISA for the manufacturing of influenza vaccines
- the Influenza A viral strain (H1N1) used for the manufacturing is the one issued by the World Health Organization

ANVISA will need to be formally notified by the Marketing Authorization Holder/ manufacturer immediately after reception of the viral strain for production of the vaccine.

From the reception of the strain, the whole manufacturing process of the vaccine will be under supervision by a Regulatory Technical Committee formally established by ANVISA.

This resolution came into force on 7 May 2009.

### **India** *"Pharma Zones"*<sup>8</sup>

The Indian Central Drugs Standard Control Organisation (CDSCO) is seeking feedback on its plans to create dedicated climate controlled "pharma zones" within the cargo area of all major airports and seaports.

Proper storage and examination of pharmaceutical products meant for import or export in accordance with good manufacturing and distribution practices will be performed in these zones mentioned by the CDSCO. This system aims to preserve the quality, safety and efficacy of pharmaceuticals being transported and this will ensure no cross contamination of medicines with other products. The deadline for comments on the draft plan was 15 June 2009.

In India, the Indira Gandhi International airport in Delhi will be the first zone to be set up which is a major

pharmaceutical trading hub.

An area of approximately 3,700 m<sup>2</sup> will be allocated for this zone and among other things, it would include a cold room facility with varied temperature zones (-20° to 8°C), a comfort zone (with temperatures below 25°C) for the examination of pharmaceuticals, and a basic testing facility to check samples of pharma products.

Separately, new measures have been initiated by the Indian Ministry of Commerce and Industry in order to combat criticism from some countries that drugs being exported by Indian manufacturers do not meet international quality standards.

A public notice was issued by the Directorate General of Foreign Trade to inform new procedures/guidelines to strengthen the enforcement mechanism available under the Drugs and Cosmetics Act 1940, to ensure that counterfeit drugs do not get exported from India. As per this notification a copy of the certificate of analysis issued by the manufacturer for the subject product along with other documents will be requested to every exporter of drugs and pharmaceuticals, at the time of shipment.

### **New Zealand** *GMP Code Updated*<sup>10</sup>

Proposals to change the New Zealand Code of Good Manufacturing Practice have been announced by the New Zealand's regulatory agency Medsafe. Comments on the proposals from Stakeholders were until 15 May 2009. These proposals aim to bring the New Zealand Code of Good Manufacturing Practice in line with the international GMP codes.

These updates intend to incorporate developments in international codes of GMP and developments with respect to new or improved technologies; to ensure New Zealand's requirements and manufacturers remain up to date in an increasingly global manufacturing environment; improve the specific guidance for particular industry sectors - for example, manufacturers of sterile medicines and of active pharmaceutical ingredients; improve the guidance for key components of quality manage-

ment - for example, validation and qualification activities; and to support provision of GMP certification to New Zealand's mutual recognition agreement partners on behalf of New Zealand manufacturers exporting medicines to other countries.

Stakeholders were expected to be informed by Medsafe of its final decision on 15 June and will publish the updated edition of the NZ Code of GMP on 1 July, which will come into effect on 1 September.

### **Philippines** *Streamlining Drug Registration Processes*<sup>9</sup>

Measures to streamline the registration process of pharmaceutical products have been proposed by the Philippines Bureau of Food And Drugs. These measures aim at improving patient access to medicines. The use and implementation of electronic data messages, documents, and signatures for product registration can be implemented in July if the proposal is finalised.

The proposed measures have been outlined in the form of a draft administrative order, which would apply to all pharmaceutical products for human use (except traditional and herbal medicines). It would also cover all manufacturers, traders, importers, exporters and distributors of these products.

By this order for a drug not registered with the agency, manufacturing, importing, exporting, selling, distributing, transferring, promoting or advertising would become illegal. Comments on the proposed measures were accepted until 30 April 2009.

### **United States** *OTC - New Labeling for Analgesics, Antipyretics and Antirheumatics*<sup>11</sup>

The Food and Drug Administration (FDA) released on 28 April 2009 final rule 21 CFR Part 201 (Final rule) for manufacturers of Over-The-Counter (OTC) Internal Analgesic, Antipyretic, and Antirheumatic (IAAA) drug products. Manufacturers of these drugs will need to revise their labeling in order to include warnings about potential safety

*Concludes on page 58.*

risks such as internal bleeding and liver damage, associated with the use of these popular drugs like acetaminophen and nonsteroidal anti-inflammatory drugs (NSAIDs) like aspirin, ibuprofen, naproxen, and ketoprofen.

This new labeling is required for all OTC IAAA drug products whether marketed under an OTC drug monograph or an approved new drug application (NDA).

According to the rule manufacturers must relabel their products within one year to include a warning and ensure that the active ingredients of these drugs are prominently displayed on the drug labels on both the packages and bottles.

This final rule from the FDA is aimed at helping consumers to use these products safely.

## *Ongoing Safety Review of Botox and Botox Cosmetic<sup>12</sup>*

The FDA published a safety review in April 2009 – a follow up to the 8 February 2008 Early Communication about an Ongoing Safety Review of Botox and Botox Cosmetic (Botulinum toxin Type A) and Myobloc (Botulinum toxin Type B).

As the result of an ongoing safety review, the FDA has notified manufacturers of licensed botulinum toxin products of the need to strengthen warnings in product labeling, and add a boxed warning, regarding the risk of adverse events when the effects of the toxin spread beyond the site where it was injected.

FDA also has notified the manufacturers that development and implementation of a Risk Evaluation and Mitigation Strategy (REMS) is necessary to ensure that the benefits of the product outweigh the risks.

In addition, FDA is requiring the manufacturers to submit safety data after multiple administrations of the product in a specified number of children and adults with spasticity to assess the signal of serious risk regarding distant spread of toxin effects.

## References

1. The Regulatory Affairs Journal, May 2009.  
DMA, Report: Product Defects and Recalls of Pharmaceuticals in 2008, 31 March 2009, <http://www.laegemiddelstyrelsen.dk/1024/visLSArtikelBredSkema.asp?artikelID=14893#forfalskede>
2. <http://www.mhra.gov.uk>
3. Published by the Stationery Office, <http://www.opsi.gov.uk>
4. The Regulatory Affairs Journal, May 2009.  
MHRA press release, 6 May 2009, <http://www.mhra.gov.uk/NewsCentre/Pressreleases/CON046496>
5. IEGM (General Directorate of Pharmaceuticals and Pharmacy), <http://www.iegm.gov.tr>
6. The Regulatory Affairs Journal, May 2009.  
The ASEAN member states are Brunei Darussalam, Cambodia, Indonesia, Laos, Malaysia, Myanmar, Philippines, Singapore, Thailand and Vietnam.
  - ASEAN Bulletin, 10 April 2009, <http://www.aseansec.org/Bulletin-Apr-09.htm#Article-6>
  - ASEAN, Fact sheet on the MRA, 10 April 2009, <http://www.aseansec.org/Fact%20Sheet/AEC/2009-AEC-026.pdf>
  - ASEAN Sectoral Mutual Recognition Arrangement for good manufacturing practice (GMP) inspection of manufacturers of medicinal products, 10 April 2009, <http://www.aseansec.org/22481.pdf>
7. The Regulatory Affairs Journal, May 2009.  
Diário Oficial da União (DOU) No. 85, of 7 May 2009, <http://www.in.gov.br>
8. • CDSCO, General Notice, 14 May 2009, <http://www.cdsc.nic.in/General%20Notice.doc>
- CDSCO, Presentation on Pharma Zone, 14 May 2009, <http://www.cdsc.nic.in/Pharma%20Zone.pdf>
- Pharmexcil, Circular to members, Ref: PXL/H.O./CIR-013/2009-10, 14 May 2009, <http://www.pharmexcil.com/v1.aspx/viewNewsBulletin.aspx?ID=540>
- Directorate General of Foreign Trade, Public Notice No. 173 (RE-2008)/2004-2009, 13 April 2009, <http://164.100.9.245/exim/2000/pn/pn08/pn17308.htm>
9. The Regulatory Affairs Journal, May 2009.
  - BFAD, Streamlined Rules and Regulations on the Registration System of Pharmaceutical Products for Human Use Amending for this Purpose Administrative Order No 67 s. 1989, Issuances Supplementing the same, and for other purposes, 23 April 2009, <http://www.bfad.gov.ph/default.cfm?isdraft=1&cid=673>
  - BFAD circular, 21 January 2009, <http://www.bfad.gov.ph/cfc/pdf.cfm?pdfid=1108>
  - Philippines government press release, 21 May 2009, [http://www.gov.ph/index.php?option=com\\_content&task=view&id=2000617&Itemid=2](http://www.gov.ph/index.php?option=com_content&task=view&id=2000617&Itemid=2)
10. The Regulatory Affairs Journal, May 2009.  
Medsafe, Proposed update to the New Zealand Code of Good Manufacturing Practice, 16 March 2009, <http://www.medsafe.govt.nz/hot/Consultation/GMP%20Review.asp>
11. <http://www.Idrac.com>; FDA, Medicines Agency, <http://www.fda.gov>
12. <http://www.Idrac.com>; FDA, Medicines Agency, <http://www.fda.gov>

*This information was provided by Frank Sayala and Rohini Chari, Pharmaceutical Research Associates (UK).*

# ISPE09

## Annual Meeting

### Thriving In A Survival Environment

8 - 11 November • Manchester Grand Hyatt San Diego • San Diego • California, USA

#### Eleven Session Tracks:

- Product development
- Supply chain management
- Quality systems
- Suppliers
- Facilities and equipment
- Production systems
- Project management
- Survival-focused
- Information systems
- Regulatory compliance
- Investigational products

Watch for details and online registration at [www.ISPE.org/annualmeeting](http://www.ISPE.org/annualmeeting).

Exhibit and Sponsorship Opportunities Available

ENGINEERING PHARMACEUTICAL INNOVATION



## PQLI Tours Asia

As a key part of PQLI's global strategy spearheading with practical implementation examples of ICH guidelines Q8, Q9, and Q10, interactive sessions were held at the Indian Affiliate Annual Meeting in Mumbai on 13 and 14 April and at the Japan Affiliate Annual Meeting in Tokyo on 16 and 17 April.

A Western team was active at both meetings and included Jim Spavins, Vice President, Global CMC, Pfizer Inc.; Roger Nosal, Executive Director, Regulatory CMC, Pfizer Global Research; and Chris Potter, CMC Consultant and Technical Project Manager for ISPE's PQLI® Initiative. Ranjit Deshmukh, Senior Director of Wyeth, was a member of the team in Mumbai.

Input was provided by US FDA speakers Rick Friedman, Director, FDA/DMPQ, who discussed global supply chain challenges for regulators and industry, and Tara Goen, Compliance Officer, FDA/DMPQ, who discussed the recent FDA draft guidance on process validation at both meetings. Both presentations were pre-recorded. In Tokyo, Yukio Hiyama, Chief, Third Section, Division of Drugs, NIHS, presented and was part of the Q&A session. Hiyamasan summarized the current position

following the introduction of ICH Q8, Q9, and Q10 in Japan, particularly the status of the various MHLW work groups.

Spavins led the Western team with a presentation on the benefits and value to the industry of conducting enhanced approaches using Quality by Design (QbD). Nosal provided Pfizer's experiences in filing QbD submissions and also summarized the latest activities of PQLI teams working on Critical Quality Attributes/Critical Process Parameters (originally Criticality), Design Space, and Control Strategy topics. Potter provided an overview of the PQLI vision and status, discussed the recently published *Journal of Pharmaceutical Innovation (JPI)* paper on application of QbD to existing products, as well as summarized a case study on the application of real-time release testing to a solid dosage form provided by AstraZeneca. In Mumbai, Deshmukh presented a Wyeth case study.

In Japan, a vote was held on potential PQLI future topics, with process vali-

ation and scale-independent design space being very clear winners.

The Indian organizing committee was led by Gopal Nair, under the overall leadership of Ajit Singh. Nair was supported by Manasi Baidur from ISPE India. The PQLI session was chaired by R. Raghunandan, Director of ISPE India.

In Japan, the meeting organizing committee was chaired by Tatsuro Miyagawa, Executive Vice-President, Daiichi Sankyo Propharma, who was supported by Natsumi Sahara from ISPE Japan. Yoshio Kitazawa, Chairman of the Japanese PQLI Steering Committee, co-chaired the PQLI session with Potter.

The recorded version of the PQLI webinar available is at [www.ISPE.org/pqli](http://www.ISPE.org/pqli). 

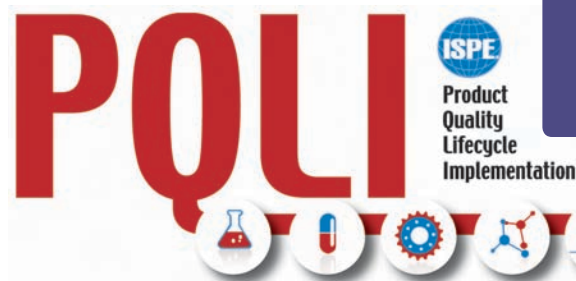

Reprinted from  
PHARMACEUTICAL  
ENGINEERING®  
The Official Magazine of ISPE  
July/August 2009,  
Vol. 29 No.4  
©Copyright ISPE 2009  
[www.ISPE.org](http://www.ISPE.org)

## Global Regulators and ISPE Members Make for Washington Conference Success

Multiple time zones and great distances could not stop pharmaceutical industry leaders from sharing their knowledge at ISPE's Engineering Regulatory Compliance Conference held in Washington, D.C., USA from 1-4 June. For the first time at an American ISPE conference, select content from among its lineup of speakers was recorded and is accessible as downloadable webinars for those industry professionals who were unable to attend. Content was also delivered virtually via live Webcasts and live online speaker presentations. To access the selection of Washington Webcasts and Webinars, visit [www.ispe.org](http://www.ispe.org).

A popular seminar was "Global Supply Chain Integrity and Anti-counterfeiting" – co-sponsored by IPEC–Americas.

This seminar brought together a panel of industry leaders and US FDA regulators to help the pharmaceutical industry address recent concerns about the integrity of today's complex pharmaceutical supply chain and to help companies assure a safe, efficacious drug supply.

Industry leaders from around the world were also able to deliver their content virtually via live Webcasts, during which on-site and off-site participants could participate in Question and Answer periods with speakers located in India and Italy. Attendees rated these sessions very highly and felt that the virtual Q&A exchanges were as good as if every participant was on site. 

## ISPE Launches Three New Online Learning Product Lines

ISPE has introduced three new Online Learning products: the ISPE 2009 Washington Conference Session series, the Certified Pharmaceutical Industry Professional™ (CPIP™) Online Course series, and the Good Manufacturing Practices (GMP) Online Training Course series.

“With the increased restrictions placed on executive travel, and the demand for education remaining stronger than ever, ISPE’s latest Online Learning offerings will truly accommodate a multitude of training needs in today’s challenging economy,” said Robert P. Best, President and CEO of ISPE. “Having access to an expert directly from their desktops is what most pharmaceutical professionals want, and as the leader in pharmaceutical education, ISPE can supply that with its expanding library of Online Learning opportunities.”

ISPE has made select sessions from its successful 2009 Washington Conference available as downloadable Webinars. Those industry professionals who were unable to attend the conference can still benefit from the numerous global regulators – including those from the World Health Organization and the U.S. Food and Drug Administration – who shared their expertise with participants on topics ranging from global supply chain integrity to validation and quality by design.

*“With the increased restrictions placed on executive travel, and the demand for education remaining stronger than ever, ISPE’s latest Online Learning offerings will truly accommodate a multitude of training needs in today’s challenging economy...”*

**Robert P. Best, President and CEO of ISPE**

The Certified Pharmaceutical Industry Professional (CPIP) Online Course series provides a broad range of learning opportunities for career growth and professional development. The CPIP series of self-directed online courses is designed for two groups: those pharmaceutical professionals who are hoping to obtain general pharmaceutical industry knowledge from drug product development through manufacturing, as well as to those who are seeking industry-wide recognition of accumulated experience via the CPIP credential.

Developed in cooperation with the global leader in GMP training, the GMP Institute, the pre-recorded Good Automated Manufacturing Practice Training Online Course series is being developed and reviewed by expert instructors and international regulatory advisors. Each 60 or 90 minute event will provide an interactive learning experience that includes a pre-assessment to identify knowledge gaps, a downloadable course presentation for note-taking, learning reviews/assessments highlighting important points, links to various web pages, an online resource handout as a quick reference for all web links discussed, and a summary of the assessments to gauge knowledge gained.

Each of these webinars can be found in ISPE’s Online Learning Catalog, which features course titles for every recorded ISPE webinar and online course sorted by topic, title, and area of interest. Each event is led by an industry leader, subject matter expert, or a member of one of ISPE’s Communities of Practice (COPs) and is available in a convenient and cost-effective recorded format at [www.ISPE.org/onlinelearning](http://www.ISPE.org/onlinelearning). 

## ISPE Strasbourg Conference to Focus on Managing Knowledge through Science and Risk Assessment

The ISPE Strasbourg Conference will be held 28 September – 1 October at the Palais des Congrès, Strasbourg, France. The conference will feature the following seminars:

- Commissioning and Qualification: Practical Applications of Science and Risk-based Approaches to Validation
- Disposables and Containment Technology in Biomanufacturing: Managing Risk, Reducing Cost
- GAMP® 5 Operational Aspects
- Barrier Isolation Forum, Innovation Updates and New Case Studies
- Investigational Medicinal Product (IP) Innovation in a Regulated Environment
- PQLI®: Global Realisation and Implementation of the ICH Quality Vision

Training Courses:

- Basic Principles of Computerised System Compliance (GAMP 5)
- Cleaning Validation Principles

More detailed information about this event is available at [www.ISPE.org](http://www.ISPE.org). 

Continued on page 62.

## Event to Showcase Facility of the Year Award Winners from DACH Region

In the last three years, companies from the ISPE Germany/Austria/Switzerland (DACH) Affiliate have won many of the awards presented by ISPE's Facility of the Year Awards program, including an Overall Winner award. To highlight the latest state-of-the-art developments being implemented by these award-winning manufacturers and their suppliers, the **Facility of the Year: Innovation Showcase** will be held **2-3 November 2009** in **Ulm, Germany**.



The event will include case studies on innovation and background on the projects, Q&A sessions, a networking reception, and site visits to some of the award-winning facilities. Presentations will cover research, development, clinical trials manufacturing, biologics, vaccines, sterile fill/finish, and oral solid dosage production. Speakers will illustrate innovative project execution, facility integration, process design, and operational excellence. More detailed information about this event is available at [www.ISPE.org](http://www.ISPE.org). 

## New ISPE Technical Document and Webinar Offer Pragmatic Solutions to Maintenance Issues

The new *ISPE Good Practice Guide: Maintenance* provides current, established practices to help achieve technical and regulatory accuracy and cost-effective compliance whether in a new maintenance program or reviewing an existing program for effective strategy and efficiency. The Guide is intended to be used as a tool for the development, implementation, and execution of a maintenance program in a manufacturing environment. The Guide is focused on maintenance in cGMP areas where maintenance strategies, plans, SOPs, and quality procedures and policy application are developed.

Because the Guide was written by a group of maintenance professionals from many pharmaceutical companies from around the world – and reviewed by the US Food and Drug Administration – it is in fact a benchmarking tool. The key concepts in this Guide can be used knowing that they have general acceptance in the industry.

As with all ISPE technical documents, the *ISPE Good Practice Guide: Maintenance* utilizes a practical, pragmatic, non-theoretical approach, giving the reader guidance on solving problems and serving as a valuable tool for addressing regulatory inspections and compliance issues. Of particular interest in the Guide is the “Reliability Curve” graphic illustration and the Table of Regulatory Citations.

In tandem with the global release of the *ISPE Good Practice Guide: Maintenance*, is the offering of a 60-minute webinar, “Launch of the ISPE Good Practice Guide: Maintenance.” This webinar identifies how the new guide can provide solutions for structuring a maintenance program and provides practical tools that will help ensure quality and compliance of maintenance operations. More detailed information on the Guide and Webinar is available at [www.ISPE.org](http://www.ISPE.org). 

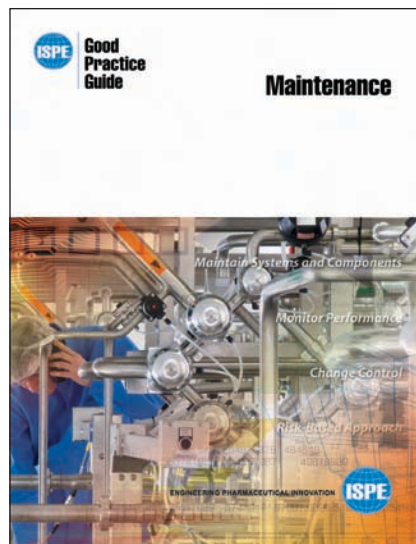

## Sichuan University Student Chapter Takes on Glossary Translation

The ISPE Student Chapter at Sichuan University is still new, but the Student Members have already completed a major project that will significantly impact the pharmaceutical engineering industry in China. At the request of the China Affiliate Steering Committee, members of the Student Chapter agreed to undertake the translation of the ISPE glossary from English to Mandarin Chinese. They began work in the middle of January and finished at the end of April. The translation from A to Z totaled 5,963 words and phrases. In addition, they helped combine the material into several convenient groups for upcoming review by industry experts. The Sichuan University Student Chapter has 107 members and is led by President Zhang Yiwen. For more information, visit the ISPE China Affiliate Web site, which can be accessed through [www.ISPE.org](http://www.ISPE.org). 

# New Knowledge Briefs Published

ISPE just released the **Removal of “Use by Dates” from Clinical Trial Material Labels in the European Union** by Michael A. Arnold. This Knowledge Brief explains how – through a risk analysis – IVR/IWR technology may be a better alternative to the conventional method of managing “use by dates.” Guidance is also provided on how to notify authorities of an intent to use IVR/IWR technology.

Also new and available is **Dry Powder Sampling and the Containment of Hazardous Compounds** by Jonathan Lind. This Knowledge Brief provides a high level review of the requirements for the successful containment of hazardous compounds associated with dry powder sampling activities.

Knowledge Briefs are concise, summary documents that provide general information on issues, processes, and technologies impacting the contemporary pharmaceutical industry. Although it may contain technical content, Knowledge Briefs are written in terms a non-technical reader can understand and are intended to help industry professionals get up-to-speed quickly on a particular topic. Each brief includes links to additional ISPE resources such as technical documents, *Pharmaceutical Engineering* articles, webinars, Communities of Practice, and educational seminars and training courses to provide more specific and detailed information on the subject.

Knowledge Briefs are available for immediate download (free to ISPE Members, \$5 US / €3 for nonmembers) from [www.ISPE.org/knowledgebriefs](http://www.ISPE.org/knowledgebriefs). The following is a list of additional Knowledge Briefs:

## Overview: Regulatory Framework – US FDA

by Dr. Kate McCormick

This Knowledge Brief provides a basic overview of the US FDA's organizational structure and licensing procedures relevant to pharmaceutical manufacturing and regulation.

## Overview: Regulatory Framework – EMEA

by Dr. Kate McCormick

This Knowledge Brief provides a basic overview of the EMEA's organizational structure, responsibilities, and regulations relevant to the manufacture of medicinal products.



## Overview: Regulatory Framework – PIC/S and ICH

by Dr. Kate McCormick

This Knowledge Brief provides a basic overview of the establishment and purpose of these two organizations and PIC/S and ICH publications pertinent to the pharmaceutical manufacturer.

## Packaging Equipment: Slat Fillers

by James Hills

This Knowledge Brief provides a basic overview of the general concept and design of the slat filler and addresses several considerations important to achieving maximum operational efficiency.

## Reducing the Cost of Manufacturing

by John Nichols

This Knowledge Brief provides an overview of how Targeted Processes, Process Intensification, and Lean/Continuous Manufacturing will serve as key techniques and technologies to reduce the cost of pharmaceutical manufacturing today and in the future.

## Risk-Based Approaches to Cross Contamination

by Stephanie Wilkins

The concepts presented in this Knowledge Brief were developed from the *ISPE Baseline® Guide, the Risk-Based Manufacture of Pharmaceutical Products (Risk-MaPP) – A Guide to Managing Risks Associated with Cross Contamination*, which is currently being reviewed by the US FDA.

## Biotechnology Basics

Adapted from the ISPE Training Course on Biotech Basics This Knowledge Brief provides basic concepts explaining the science of biotechnology and how science and process are combined to lead to the manufacture of a human therapeutic product.

## Commissioning and Qualification of Biopharmaceutical Facilities

The information contained in this Knowledge Brief was extracted from the *ISPE Baseline® Guide: Biopharmaceutical Facilities*, authored by the Biopharmaceutical Manufacturing Facilities Baseline® Guide Task Team

This Knowledge Brief summarizes the considerations involved in the commissioning and qualification of a biopharmaceutical manufacturing facility.

## Quality by Design

by John Berridge, PhD

This Knowledge Brief provides and explains the basic elements of Quality by Design (QbD). 



## Architects, Engineers – Constructors

**CRB Consulting Engineers**, 7410 N.W. Tiffany Springs Pkwy., Suite 100, Kansas City, MO 64153. (816) 880-9800. See our ad in this issue.

**Parsons**, 150 Federal St., Boston, MA 02110. (617)-946-9400. See our ad in this issue.

## Cleanroom Products/Services

**AES Clean Technology**, 422 Stump Rd., Montgomeryville, PA 18936. (215) 393-6810. See our ad in this issue.

**Plascore**, 615 N. Fairview, Zeeland, MI 49464. (800) 630-9257. See our ad in this issue.

## Dust Collectors

**Farr APC**, 3505 S. Airport Dr., Jonesboro, AR 72401. (866) 530-5474. See our ad in this issue.

## Employment Search Firms

**Jim Crumpley & Associates**, 1200 E. Woodhurst Dr., Bldg. B-400, Springfield, MO 65804. (417) 882-7555. See our ad in this issue.

**Robert Drexler Associates, Inc.**, PO Box 151, Saddle River, NJ 07458. (201) 760-2300. See our ad in this issue.

## Instrumentation

**Hach Co.**, 5600 Lindbergh Dr., Loveland, CO 80539. (970) 663-1377. See our ad in this issue.

## Passivation and Contract Cleaning Services

**Active Chemical Corp.**, 4520 Old Lincoln Hwy., Oakford, PA 19053. (215) 676-1111. See our ad in this issue.

**Cal-Chem Corp.**, 2102 Merced Ave., South El Monte, CA 91733. (800) 444-6786. See our ad in this issue.

## Processing Systems

**GEA Process Engineering**, 9165 Rumsey Rd., Columbia, MD 21045. See our ad in this issue.

## Rupture Discs

**Fike Corp.**, 704 SW 10th St., Blue Springs, MO 64015. (816) 655-4546. See our ad in this issue.

## Sterile Products Manufacturing

**Process Tek - Sterility by Design**  
INNOVATION, RELIABILITY & PROFESSIONALISM  
R&D, Validation, GMP Auditing,  
HACCP, Problem Solving and Training  
for sterile products, packages & processes  
Kailash S. Purohit, PhD  
www.processtek.net • kaipurohit@processtek.net

## Temperature Control Systems

**Budzar Industries**, 38241 Willoughby Pkwy., Willoughby, OH 44094, (440) 918-0505. See our ad in this issue.

**CAL-CHEM CORPORATION**  
NOT JUST ANOTHER CONTRACTOR, BUT A PARTNER...

*"Follow Through"*

"Follow Through" is critical in today's technical market. Cal-Chem offers today's industries solutions for a wide variety of precision cleaning and passivation, while preparing for tomorrow's challenges.

**CAL-CHEM CORP**

visit our web site for more information: [www.cal-chem.com](http://www.cal-chem.com)  
or call us at:  
**800-444-6786**  
Offices conveniently located on the East and West Coast

**ISPE Good Practice Guide: Maintenance**

**Now Available!**

Order on-line at [www.ISPE.org/publications](http://www.ISPE.org/publications)

**JIM CRUMPLEY & ASSOCIATES**  
Pharmaceutical Recruiting Specialist  
Put our expertise to work for you in:

- Facilities
- Project
- Process
- Validation
- Automation
- Quality Engineering

1200 E. Woodhurst Drive, B-400 • Springfield, MO 65804  
Phone: 417-882-7555 Fax: 417-882-8555  
E-mail: [recruiter@crumpleyjobs.com](mailto:recruiter@crumpleyjobs.com)  
Web site: [www.crumpleyjobs.com](http://www.crumpleyjobs.com)  
*We've been getting results since 1977!*

## Validation Services

**Commissioning Agents, Inc.**, 1515 N. Girls School Rd., Indianapolis, IN 46214. (317) 710-1530. See our ad in this issue.

## Valves

**Gemu GmbH & Co.**, Fritz-Mueller-Str. 6-8, D-74653 Ingelfingen, Germany. +49 7940123-0. See our ad in this issue.

## Vial Traying Systems

**Hurst Corp.**, Box 737, Devon, PA 19333. (610) 687-2404. See our ad in this issue.

## Water Treatment

**Elettracqua Srl**, Via Adamoli 513, 16141 Genova, Italy. +39 0108300014. See our ad in this issue.

**MECO**, 12505 Reed Rd., Suite 100, Sugar Land, TX 77478. (800) 421-1798. See our ad in this issue.

**Siemens Water Technologies**, 10 Technology Dr., Lowell, MA 01851. (978) 934-9349. See our ad in this issue.

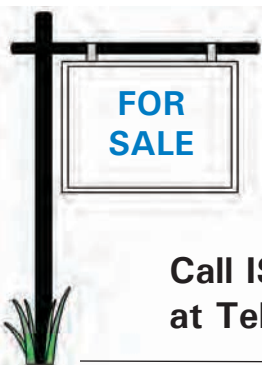

## Advertising Space Available

Call ISPE Director of Sales Dave Hall at Tel: + 1-813-960-2105.

Inc. 1955



## ACTIVE CHEMICAL CORP.

### SPECIALISTS IN . . .

#### — LABORATORY CONTROLLED —

- CHEMICAL CLEANING SERVICES OF HEAT EXCHANGE EQUIPMENT
- PASSIVATION OF STAINLESS STEEL PIPING
- STERILIZATION OF PIPING & EQUIPMENT
- SOFTENERS & DEIONIZERS
- RECONDITIONING OF FILTERS & ION EXCHANGERS
- WATER TREATING CONSULTANTS
- BOILER & COOLING WATER CHEMICALS

#### SERVICE CONTRACTS

**(215) 676-1111**

4520 Old Lincoln Hwy.,  
Oakford, PA 19053



## DELABELING SOLUTIONS

for

- SYRINGES\*
- CARTRIDGES
- GLASS VIALS
- PLASTIC VIALS
- METAL CANISTERS

\*new 2009

Information:  
[www.hurstcorp.com](http://www.hurstcorp.com)

**Other HURST products:**  
Automatic vial TrayLoaders,  
plastic vial trays and custom made  
stainless steel products.



**HURST CORPORATION 610-687-2404**

Box 737 - Devon, Pennsylvania 19333 - USA

**EI ASSOCIATES**



ARCHITECTURE  
ENGINEERING  
CONSTRUCTION

SINGLE SOURCE RESPONSIBILITY

*From Benchtop to Distribution*

*We Understand Your GxP Facilities.*



Research  
API  
Manufacturing  
Finishing  
Support



INTERPEX 2009  
Visit us at  
**Booth #1242**

8 Ridgedale Avenue, Cedar Knolls, NJ 07927 – 973-775-7777

Contact: [guy\\_cipriano@eiasociates.com](mailto:guy_cipriano@eiasociates.com) – ext. 378

# Thank You to our Sponsors

## ISPE Washington Conference

### Platinum Sponsors



### Gold Sponsors



### Lanyard Sponsor



### Onsite Advertising Sponsor



## ISPE Strasbourg Conference

### Host Sponsor



### France Affiliate Networking Event Sponsor



### IP COP Networking Event Sponsors



ACTIVE CHEMICAL .....	65
AES CLEAN TECHNOLOGY .....	7
BUDZAR INDUSTRIES .....	55
CAL-CHEM CORP. ....	64
CHEM SHOW .....	39
COMMISSIONING AGENTS .....	9
CRB CONSULTING ENGINEERS .....	3
JIM CRUMPLEY & ASSOCIATES .....	64
EI ASSOCIATES .....	65
ELETTRACQUA .....	11
FARR AIR POLLUTION CONTROL .....	2
FIKE CORP. ....	33
GE WATER & PROCESS TECHNOLOGIES .....	25
GEA PROCESS ENGINEERING .....	31
GEMU GMBH .....	45
HACH COMPANY .....	41
HOWORTH AIR TECHNOLOGY .....	13
HURST CORP. ....	65
IMA ACTIVE .....	47
INTELLIGEN .....	15
INTERPHEX .....	29
MECO .....	17
MURRAY COMPANY .....	27
NNE PHARMAPLAN .....	68
PARSONS .....	5
PHARMACEUTICAL ONLINE .....	51
PLASCORE .....	35
SIEMENS WATER TECHNOLOGIES .....	21

# more than engineering

"ASTM E2500 is a critical **opportunity** for our industry. Companies are realising cost reductions of **40%** or more. NNE Pharmaplan is a **thought leader** and unique in its expertise. We would like a chance to **prove** it to you."

We **lead**. We **deliver**.  
We are **more than engineering**.



Consulting



Engineering



Construction



Validation



Solutions

To succeed in today's market, you require a focused partner created from industry DNA who can deliver a competitive advantage.

For more information on our ASTM E2500 know-how, please write to [contact@nnepharmaplan.com](mailto:contact@nnepharmaplan.com)

nne pharmaplan®

[nnepharmaplan.com](http://nnepharmaplan.com)

This article presents electro membrane technology for improving yield of bioreactor processes.

# Electro Membrane Technology Boosting Bioreactor Processes

by René Fuhlendorff, Arvid Garde, and Jens-Ulrik Rype

## Introduction

**E**lectrochemical processes are chemical processes in which an electrical potential is acting as the driving force for the electrochemical reactions involved in the process. Historically, such electrochemical processes have had its industrial use in the manufacturing and purification processes involving almost exclusively small molecules and salts supporting the widespread use of such in the chemical industry.

Electrochemical principles have been applied in processes of various purposes; including the formation of new compounds by using the electrical potential to drive the reduction and oxidation processes toward such entities; and within separation technology by using the electrical potential to separate compounds from a complex solution as in electro membrane separations; and with the developments and shift in the manufacturing industry from chemical syntheses toward biochemical processes and microbial cell factories strong focus on larger molecules, primary metabolites, and secondary metabolites.

A widespread use of fermentation and bioreactor processes are seen today across several industries. Examples of products are bioethanol, amino acids, nucleotides, vitamins, organic acids, vaccines, polysaccharides, antibiotics, and therapeutic proteins from cell-culture processes. Fermentative production of vitamins has replaced many synthetic vitamin production processes and enzymatic and cell-based bioconversions are becoming essential for the production of fine chemicals single isomers and bio energy. The discovery of recombinant DNA techniques has led to biochemical processes for large scale production of various secondary metabolites and products. Today, recombinant proteins can be produced by several different host and their expression systems, such as

bacteria, yeast, plant, and mammalian cells.

Electro membrane processes have been developed to fit such manufacturing lines both on the upstream and on the down-stream sides. Examples are the use of electro membrane separation in the production of recombinant proteins, therapeutic proteins, enzymes, probiotics, among other secondary metabolites.

New inventions and new types of polymers have opened up for a range of new separation techniques that could not have been foreseen only 20 years ago. The developments made of such polymer based techniques benefit not only the biopharmaceutical industry, but also many other industries; including, food and food ingredient industry, medico technical industry, biopolymer industry, packaging industry, down-stream processes in general, and many environmental processes in these industries.

In striving to meet higher demands of product quantity and improved efficiency of such production processes, it is becoming ever more important to scale up processes and bioreactors volume. However, design, construction, testing, and evaluation are both costly and time consuming endeavors and much effort is required to handle these challenges. Computational approaches based on fluid dynamics can be used to simulate and optimize some critical limiting factors such as non-ideal mixing, nutrient and oxygen distribution, and mass transfer in such bioreactors.<sup>1</sup> Metabolic and genetic engineering are other means to improve process efficiency and lower costs in specific applications.

The concern with bioreactor productions is not only focused on capital and operational expenditures (low volume, high purity product is desired), but also on technical and practical issues like microbial contamination, viruses, etc. Substantial R&D resources are required in order to achieve the mandatory specificity, selectivity, and productivity of such processes.

Biopharmaceutical companies also are challenged by the time-to-market with new products and by demonstrating sufficient business growth for shareholders and investors. And clearly because of the enormous costs for bringing a new product to the market as well as the implementation of small changes in a pre-approved production process, initiatives in improving productivity and yield are quite substantial to counter the additional costs related to documentation and administrative processes.

## Bioreactor Growth Rate Inhibition

Fermentation processes are often inhibited by a number of expressed products either being the end-products in question or by-products limiting growth rate, cell density, and productivity. In the typical batch fermentation with unlimited nutrients, the biomass growth rate strongly depends on the stage of the cell system, from lag phase to the exponential phase and finally to the stationary phase where product inhibition becomes controlling.

Inherent to such bioreactor processes are the fundamental challenge to achieve and prolong the exponential growth rate of the cell system in the production of biomass, products or various by-products at optimal growth conditions. After the initialization of the fermentation process, the microorganism should ideally stay in exponential phase as long as possible.

*Escherichia coli* (E. coli) is one of the most important host organisms for production of recombinant proteins and considerable effort has been made to improve the efficiency and to extend the application range of E. coli-based expression systems. Acetate formation in aerobically grown cultures of *Escherichia coli* continues to be a major problem in the industrial application of this microorganism; the presence of acetate inhibits growth<sup>2</sup> and the production of recombinant proteins,<sup>3</sup> and induces stress response even at low concentrations.<sup>4</sup> Acetate formation occurs not only under anaerobic conditions (mixed acid fermentation), but also under fully aerobic conditions with excess carbon source. When glucose is the carbon source, E. coli predominantly generates acetate as a result of overflow metabolism.<sup>5,6</sup>

Acetate formation has several other disadvantages in addition to the inhibition on production; acetate has a negative effect on the stability of intracellular proteins<sup>7</sup> and accumulation of acetate will acidify the medium. When the pH is below 5.0, cell lysis will appear due to the irreversible denaturation of proteins and DNA.<sup>8</sup> The level of acetate produced during aerobic fermentation is depending on the E. coli strain, the growth conditions, the actual glucose concentration in the medium, and the overall composition of the fermentation medium.<sup>9</sup> Acetate formation can be circumvented through different means, e.g., making the carbon source rate limiting/managing oxygen supply, but under optimal growth conditions, acetate formation will at length lead to growth inhibition.

Similarly, for several years *Lactococcus lactis* (a.o. LAB) has played a role as major production host in the food and food ingredient industry and today is Generally Recognized As Safe (GRAS) for these applications worldwide. A number of

advantages can be associated with the Gram positive organism as it allows proteins to be secreted directly to the extracellular milieu with only a limited number of side products. Also, downstream processing is considerably less complex in contrast to Gram negative bacteria as *Lactococcus lactis* does not produce endotoxins or forms inclusion bodies. Hence, the expressed recombinant protein can be isolated from the fermentation broth through simple purification processes. The last couple of decades has resulted in the development of a number of *Lactococcus lactis* based gene expression systems because of such advantages.<sup>10,11</sup>

However, the production of lactic acid – the primary end product of glucose metabolism – will have a limiting effect on biomass production in *Lactococcus lactis*. Lactic acid inhibits growth even when the acid is neutralized by the addition of base to keep pH constant resulting in relatively low cell density, which also has been the primary drawback for *Lactococcus lactis* as a host organism for producing heterologous proteins.

Various attempts to overcome growth rate inhibition have been made during the past decade<sup>12</sup> both genetically as well as physically, resulting in sub-optimal solution: Removal of inhibiting substances in bioreactor processes is an option when higher cell densities and product yields are demanded. Removing such inhibiting compounds directly (online) from the fermentation broth by a membrane separation process makes it possible to operate at much higher biomass concentration, thereby increasing the production rate as well as the final product concentration. Attempts to solve the problem of inhibitor induced growth rate reduction have led to numerous development designs and new separation techniques, which are also beneficial in the subsequent down-stream processes.

## Reverse Electro-Enhanced Dialysis (REED™) – Combining Driving Forces from Simple Dialysis into Electro Membrane Processes

For the direct removal of inhibitors from fermentation broth, several separation techniques have been investigated. While microfiltration, ultra filtration, and nano filtration are techniques primarily used in the down-stream fermentation processes, various dialysis techniques have been coupled directly to the bioreactor, including Diffusion Dialysis or Donnan Dialysis (DD), and electro assisted dialysis techniques like Electro Dialysis (ED) and Electro Dialysis Reversal (EDR).

Donnan Dialysis (DD) or Diffusion Dialysis employs the same type of ion-exchange membranes, but differs from electro dialysis in electro-membrane processes in that the driving force is not an electrical current, but simply a difference in chemical potential. As an example, a negative ion ( $A^-$ ) can be driven out of a feed solution or fermentation broth through Donnan Dialysis equipped with anion-exchange membranes, by utilizing a second alkaline stream. The concentration difference of hydroxide ions ( $OH^-$ ) between the two solutions drives the hydroxide ions to diffuse into the Feed solution. This creates an oppositely directed electrical field driving an extraction of negative ions ( $A^-$ ) from the Feed solution.

On the other hand, Electro Dialysis (ED) utilizing the

electrical potential as the main driving force in separations limits the possible targeted solutes for recovery separation to charged compounds. The charged compounds must be mobile, and the separation media must be able to transfer the electrical current with relatively low resistance. Traditional applications of Electro Dialysis are based on its ability to desalinate or concentrate a liquid process stream containing salts. ED is very useful for water treatments by removal of mineral salts, sulphates, nitrates among others in making drinking water from brackish water or sea water or for waste water reduction or recovery.

Drawbacks of the simple ED set-up lies in the fact that liquid process streams must be free of particles and high organic content in order to avoid membrane fouling. For complex process streams the benefits from Electro Dialysis Reversal (EDR) must be taken into account. EDR is operated like ED, but when fouling has grown to a certain level, the setup is altered by reversing the direction of the constant current driving the separation and either operating with “negative” reversed separation effect for a short period until returning to normal operation or by subsequently switching the dilution and concentration chambers. This way, it is possible to prolong the ED operation without having to stop and clean the equipment.

In general, *Electro membrane techniques* have in common the fundamental ability to separate charged small molecules from process streams using the electrical field as the driving force across selective ion-exchange membranes. Advanced combinations of separation techniques and designs have been developed, which compensates for some of the drawbacks of the individual techniques.

Across several industries and in various bioreactor processes, the combinations of driving forces from dialysis techniques, innovative designs of cell stacks, and material technology for electro-membrane separations have resulted in alternative routes in achieving better biomass and product yields.

*Reverse Electro Enhanced Dialysis (REED™)* is a technology that combines the principles of Donnan Dialysis (DD) and Electro Dialysis Reversal (EDR).

With the REED technology, fermentation processes can be handled without the build-up of fouling layers on the membrane surfaces seen during fermentation as the REED technology has a built-in anti-fouling mechanism, which automatically removes deposited organic components from the membrane surfaces.

Using current developments in membrane technology, the REED process is able to extract small, charged molecules like the corresponding bases of, e.g., organic acids (lactate, acetate from lactic, and acetic acid among others) separating these from larger or non-charged components like proteins, sugars, cells, yeast, etc.

REED-assisted fermentation processes with continuous extraction of growth rate reducing substances allows for significant extensions of the exponential growth phase. Such applications result in higher yields and improved capacities of the existing fermenter or bioreactor equipment. Furthermore,

the REED system is able to regulate pH of the fermentation broth by exchanging hydroxide ions with the expressed product anions, thus reducing the need for a titration agent.

Electro membrane technology including the REED technology can be integrated into the fermentation processes either as fully integrated solutions (*REED controlled fermentation*) or as simple modular device solutions (*REED Add on*).

The *REED controlled* fermentation setup is a build-in solution where the REED unit is fully integrated and controlling the fermentation process, either fed-batch or continuous fermentation. The REED unit is connected directly (on-line) to the fermenter and separates the process inhibiting acid continuously. Though the *REED controlled* fermentation setup generates the best output in active biomass (actually more than a factor of 10 times compared to unassisted fermentation), it also requires significant changes to the existing process. Obviously, such changes should be considered as early in the design phase as possible.

In the modular *REED add on* setup, the REED unit is acting as a passive unit on the fermenter; the batch fermentation setup and control is left basically untouched. Fermentation broth will pass through the REED unit removing as much organic acid as possible during the course of the fermentation. Benefits of the acid removal are prolonged exponential growth and production of more biomass.

When applied for the specific production of organic acids like high purity lactic acid for Poly Lactic Acid (PLA) production, the *REED add on* setup leaves two product streams; one directly from the REED and one from the fermenter itself. Due to the pre-filtration in the REED unit, the stream from the REED unit is of acid salt (lactate) form separated from bio matter, while the fermenter stream is unaffected. Hence, this setup provides two options of producing separate product qualities and/or pooling both streams for the conventional Down Stream Process (DSP).

In contrast to simple Electro Dialysis, more advanced electro membrane solutions are typically exploited in high-end biopharmaceutical production processes to boost bioreactor processes of high valued products like therapeutic proteins, enzymes, and various others.

Due to the highly scalable nature of such electro membrane systems, the fundamental setup can be the same: from small scale bioreactor productions (lab scale), pilot scale productions, or even to industrial applications with 100 m<sup>3</sup> tanks.

Presented in the following are case studies and results from specific REED applications from lactic acid for food ingredient production to various small scale biopharmaceutical gene expressions of recombinant proteins.

## REED Technology in Lactic Acid Production

The present case study is a suggestion for a process for production of lactic acid by lactic acid bacteria using a combination of electro membrane processes including the REED.<sup>13</sup> The process itself is generic in nature and can with very few modifications be adapted for a wide variety of other applications. These include production of various organic acids and bases and especially pharmaceutical and biotech products

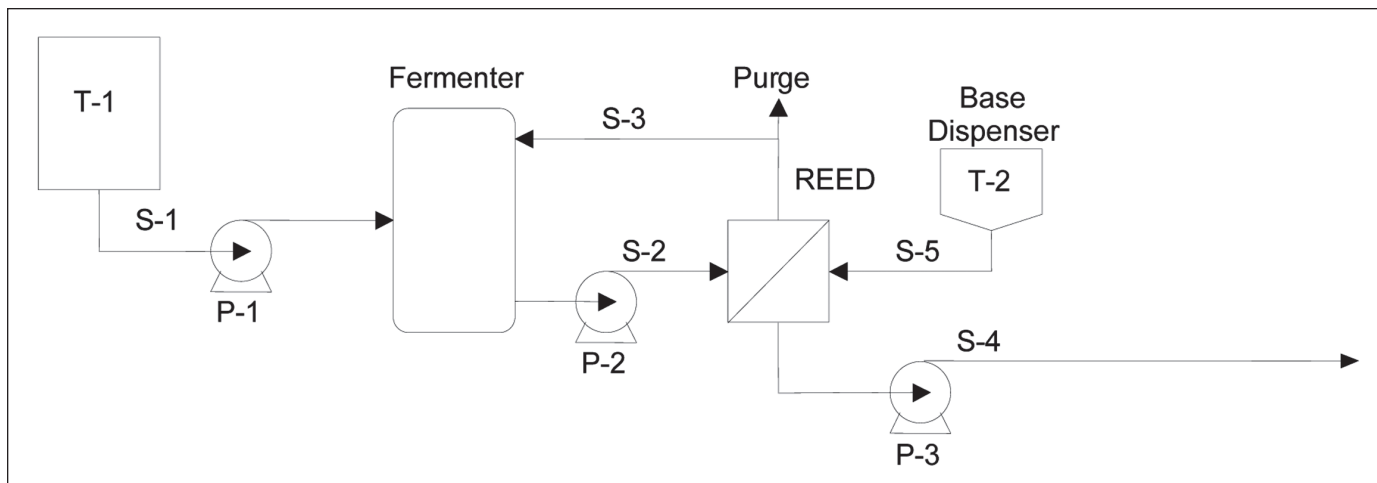

Figure 1. Process flow sheet of a lactic acid production process.

made by fermentation. However, the targeted species in the broth must be charged and have an approximate molecular weight of less than 500 g/mol.

In the application, the electro membrane separation is operated and combined with the fermentation, which makes it possible to extract the targeted ionic species, and at the same time, control the pH of the fermenter. A major advantage of the process is that no treatment to remove cells, proteins, macromolecules, calcium, magnesium, etc. is required prior to the extraction of product due to the integrated anti-fouling mechanism in the extraction unit. The lactic acid production process is shown in Figure 1.

From the feed tank, T-1, substrate is fed to the recycle fermenter where the sugar is fermented to lactic acid. A stream, S-2, is taken out, and in the Reverse Electrically Enhanced Dialysis (REED), stack lactate ions are replaced with OH<sup>-</sup> before it is sent back to the fermenter for pH control (S-3). The alkaline stream, S-4, containing lactate is pumped to a Bipolar ElectroDialysis (EDBM) system where lactate and any inorganic anions are concentrated in the acid compartment. The base is regenerated and returned to the REED after a make-up addition of base from T-2. Lactic acid is concentrated in the acid circuit of the EDBM to approximately 20 to 25%.

The synergy effect of combining REED with an EDBM system offers the possibility to continuously regenerate alkaline solution for the REED system and recover and acidify organic acids extracted from the fermentation. A less complex solution for operating the REED without the EDBM system is to add premixed alkaline solution directly to the REED and then employ other means for after-treatment of the acid salt leaving the REED.

## Unit Operations

Placed in the recycle loop of the fermenter is the REED unit, which can be adapted to conventional fermenter types.

Figure 2 shows how the electrical current through the broth feed compartments enhances the flux of acid ions (lactate), which migrates into the base compartment. In the base compartments, the hydroxide ions have a dominating transport number and are transported back to the broth instead of the

collected lactate.

Membrane fouling, a drawback of conventional electro membrane separation processes, is avoided with the current reversals in the REED technology. Without pre-filtration of the broth, the membranes will quickly be fouled, resulting in increasing electrical resistance. However, by periodically changing the direction of the current, fouling of the membranes is reversibly removed and significantly prolonged operation times are achieved. Figure 3 shows the effect of reversing the current, the resistance (voltage drop) returns to its original level after one period. Hence, continuous lactate removal is possible directly from the unfiltered broth.

Shown in Figure 4 is the potential drop across a REED-stack containing three cell pairs during removal of lactate from fermentation broth at constant current density. The resistance of the membranes is steadily increasing during the first 55 minutes as fouling is building up on the membrane surface. However, as soon as current reversal is applied every

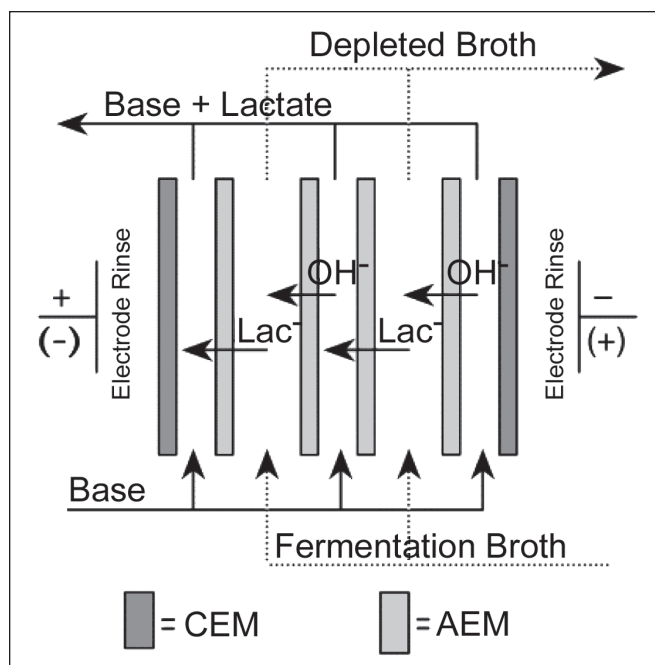

Figure 2. Ion transport in the REED unit.



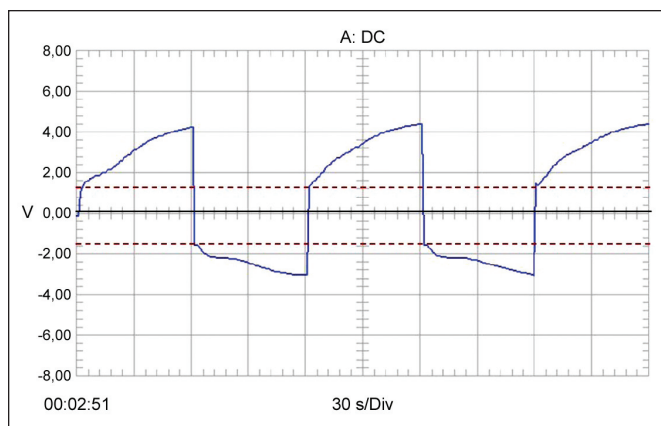

Figure 3. The curve shows the electrical potential across a cell pair upon current reversal every 60 seconds during REED operation.

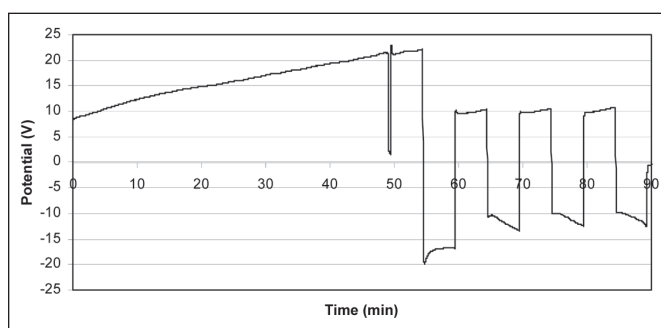

Figure 4. Potential drop across a REED-stack.

300 seconds, the self cleaning effect sets in and the potential drop (resistance) returns to near its original level.

Furthermore, by using the REED setup with anion exchange membranes, problems caused by divalent cations, such as  $\text{Ca}^{2+}$  and  $\text{Mg}^{2+}$  in the subsequent EDBM, which can not operate when these ions are present, is eliminated.

The current efficiency in the REED is very much dependent on the amount of other unwanted anions in the broth and time between current reversals. Typically, the REED operates at current efficiencies of 80 to 90%. The energy consumption (kWh/kg acid extracted) is dependent on the current density, but is typically 0.25 to 0.75 kWh/kg for lactic acid.

## REED Technology in Biopharmaceutical Gene Expression of Recombinant Proteins

The increased use of bioreactor technology in the manufacturing of biopharmaceuticals has put the focus on the development of the production system and its elements, e.g., the biopharmaceutical cell factories, the gene expressions systems, and further developments of genetic engineering technologies.

Coupling of advanced electro membrane techniques like REED with such biopharmaceutical gene expression systems can be seen as a supplement to or an alternative to the genetic engineering approach; when the work of genetic manipulation no longer can lead to further improvements of the productivity of the cell systems; such electro membrane systems can help in achieving the targeted higher productivities.

The following examples present the research of the combination of the REED technique with a specific expression system: P170 Expression System.<sup>15</sup>

## *Lactococcus lactis* with a REED Assisted P170 Expression System

The P170 Expression System<sup>16</sup> is a *Lactococcus lactis* based expression platform with an auto-induced promoter being activated when a certain threshold of lactate is reached in the *Lactococcus lactis* culture. Auto-induction eliminates the need for the addition of exogenous components to induce recombinant protein production. Optimized P170 promoter variants have been combined with optimized signal peptides, resulting in secretion of recombinant proteins.

Due to the growth rate reduction by Lactic acid, the final biomass concentrations are often below 6 g/L cell Dry Weight (DW), whereas respiring organisms easily reach 100 g/L (DW). The low cell density has been the major drawback for *Lactococcus lactis* as a host organism for producing heterologous proteins. The yield in biomass production is below that of other expression systems with cell densities of approximately 20 OD<sub>600</sub> units. With this limited cell density, the expression system has reached 300 mg/L of secreted protein. Although this level is acceptable for some high value proteins, in most cases, higher production levels are desirable.

While the accumulation of lactate gradually reduces the growth rate of *Lactococcus lactis*, it also induces protein production controlled by P170. The optimal lactate concentration for recombinant protein production is pH and protein dependent. Therefore, a method that can control the lactate concentration during fermentation will serve dual purposes: to achieve high cell densities and to prolong the phase of P170 controlled protein production. The described REED technology has recently helped to overcome this cell density problem in a combined study with the P170 Expression System. The effect of the REED unit resulted in a nine-fold increase in biomass and an increase from 300 mg/L to 2,000 mg/L for a secreted test protein.

## Expression of Protein *S. aureus* nuclease, SNase

In another study, the synergistic effect of the REED system combined with the P170 Expression System was tested in the

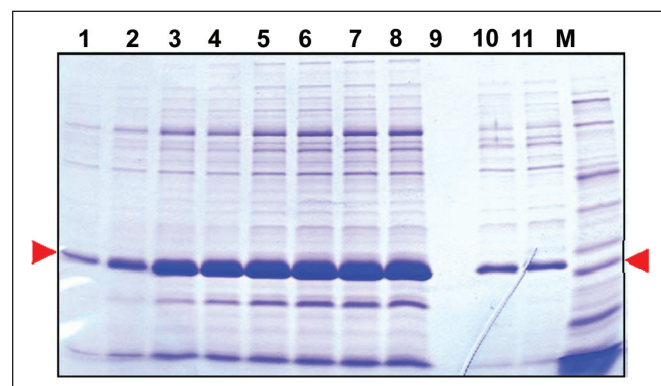

Figure 5. SDS-PAGE analyses of SNase from production in yeast extract medium.

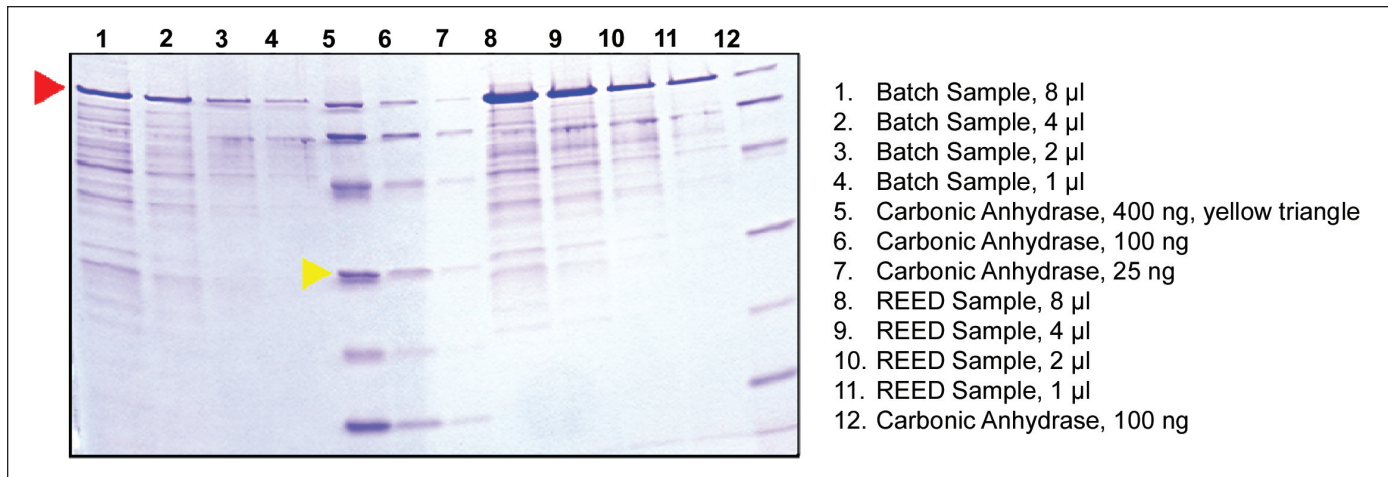

Figure 6. SDS-PAGE analyses of malaria hybrid antigen, GLURP-MSP3.

production of a secreted model protein *S. aureus* nuclease, SNase. Traditional batch fermentation was done in parallel for comparison. In the first phase, the REED unit was used to keep the lactate concentration below 150 mM, allowing rapid exponential growth. When a certain cell density was achieved (70 OD<sub>600</sub>), the lactate concentration was increased and kept between 250 to 350 mM for 21 hours. During this phase, cell growth continued at a reduced rate due to lactate inhibition, while the specific production rate of recombinant protein was continuously kept at an optimal level.

By applying REED technology, the growth phase could be prolonged resulting in a final cell density of 180 OD<sub>600</sub> units in the REED assisted fermentation in contrast to 20 OD<sub>600</sub> units in the standard batch fermentation, i.e., a nine fold improvement. Furthermore, the yield was increased more than 10 fold using REED *vs.* batch, resulting in 2 g/L of secreted nuclease in the REED fermentation.

## Malaria Vaccine Antigen, GLURP-MPS3

In a recent study, the malaria vaccine antigen, GLURP-MPS3, was produced in the P170 Expression System using standard batch fermentation. In this study, the REED assisted P170 Expression System was evaluated for increased secretion of GLURP-MSP3 with promising results.

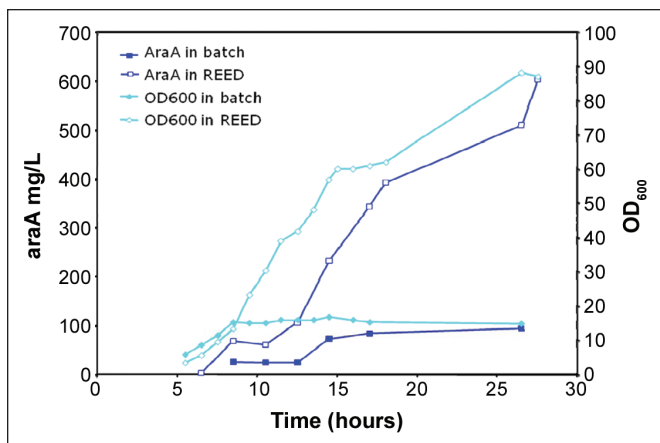

Figure 7. Production of L-arabinose isomerase (AraA) in chemically defined medium in REED assisted vs. unassisted batch productions.

The yield of secreted GLURP-MSP3 was increased four to six fold resulting in approximately 140 mg/L in the REED fermentation.

## Production of a Sugar Converting Enzyme, L-arabinose isomerase

The conversion of D-galactose to the low-calorie sweetener D-tagatose is catalyzed by L-arabinose isomerase (araA). A thermostable L-arabinose isomerase from *Thermoanaerobacter mathranii* was expressed intracellularly in the P170 Expression System and the yield of araA was evaluated in REED *vs.* batch fermentations. By applying the REED system for production of araA both yield and biomass (OD<sub>600</sub>) were increased approximately six fold from ~ 100 mg/L to ~ 600 mg/L and ~ 15 to 90 (OD<sub>600</sub>), respectively.

## Conclusion

Electro membrane technology can be used in bioreactor based processes for the production of both biomass and products leading to very pure biopharmaceuticals and chemicals.

The REED technology is a general technology based on combinations of ion-exchange membrane processes, which is applicable to removing inhibitors of bioreactor processes resulting in the production of biomass; the raw material and starting material for various biopharmaceuticals and pure chemicals in biopharmaceutical and food applications.

In contrast to other ED systems, the inherent antifouling mechanism of the REED technology allows REED modules to be directly coupled to a bioreactor/fermenter in upstream processes without the use of any other filtration and membranes techniques.

Until now, focus has been mainly on documenting the REED technology in *L. Lactis* production of lactic acid and in the production of recombinant proteins with the P170 Expression systems. Recently, the REED technology also has proven to be favorable in the removal of expressed inhibitors as well as general bioreactor pH control for *E. coli* based systems.

Primary REED-applications have been identified for production of Starter Cultures, metabolic enzymes, antibiotics or other proteins, organic acids and pure chemicals, and in

general, in separations and purifications in the recovery of high end value products in downstream processes of complex process streams.

### References

1. Dhanasekharan, K., "Design and Scale-Up of Bioreactors Using Computer Simulations," *BioProcess International*, 2006, pp. 34-41.
2. Mey, M.D., et al., "Minimizing Acetate Formation in E. coli Fermentations," *J Ind Microbiol Biotechnol*, 2007, Vol. 34, pp. 689-700.
3. Contiero, J., et al., "Effects of Mutations in Acetate Metabolism on High-Cell-Density Growth of Escherichia coli.," *J Ind Microbiol Biotechnol*, 2000, Vol. 24, pp. 421-430.
4. Gschaedler, A., et al., "Effects of Pulse Addition of Carbon Sources on Continuous Cultivation of Escherichia coli Containing a Recombinant E. coli GapA Gene," *Biotechnol Bioeng*, 1999, Vol. 63, pp. 712-720.
5. Doelle, H.W., Ewings, K.N., and Hollywood, N.W., "Regulation of Glucose Metabolism in Bacterial Systems," *Adv Biochem Eng*, 1982, pp. 1-35.
6. El-Mansi, E.M.T., and Holms, W.H., "Control of Carbon Flux to Acetate Excretion During Growth of Escherichia coli in Batch and Continuous Cultures," *J Gen Microbiol*, 1989, Vol. 11, pp. 2875-2883.
7. Stephanopoulos, G., "Metabolic Engineering," *Biotechnol Bioeng*, 1998, Vol. 58, pp. 199-120.
8. Cherrington, C., et al., "Shortchain Organic Acids at pH 5.0 Kill Escherichia coli and Salmonella spp. without Causing Membrane Perturbation," *J Appl Bacteriol*, 1991, Vol. 70, pp. 161-165.
9. Wolfe, A.J., "The Acetate Switch," *Microbiol Mol Biol Rev*, 2005, Vol. 69, pp. 12-50.
10. Bredmose, L., et al., Development of a Heterologous Gene Expression System for use in Lactococcus lactis on Host Physiology. [book auth.] Merten OW et al., **Recombinant Protein Production with Prokaryotic and Eukaryotic Cell. A Comparative View**, Dordrecht : Kluwer Academic Press, 2001.
11. Mierau, I., and Kleerebezem, M., "10 Years of the Nisin-Controlled Expression System (NICE) in Lactococcus lactis," *Appl Microbiol Biotechnol*, 2005, Vol. 68, pp. 705-717.
12. Narayanan, N., "L (+) Lactic Acid Fermentation and its Product Polymerization," *Journal of Biotechnology*, 2004, Vol. 7, pp. 167-179.
13. Rype, J.-U., **Modelling of Electrically Driven Membrane Processes**, Department of Chemical Engineering, Technical University of Denmark, Copenhagen: s.n., 2002. pp. 147-166, Ph.D. Thesis.
14. Straathof, A. J.J. et al., "Feasibility of Acrylic Acid Production by Fermentation," *Appl Microbiol Biotechnol*, 2005, Vol. 67, pp. 727-734.
15. Madsen, S.M., and MacDonald, S.A., "Bacterial Systems Breed New Expectation," s.l.: Samedan LTD Pharmaceutical Publishers, Autumn 2006, *European BioPharmaceutical Review*, pp. 122-126.
16. Madsen, S.M., et al., "Molecular Characterization of the

pH-Inducible and Growth-Phase Dependent Promoter P170 of Lactococcus lactis MG1363," *Mol Microbiol*, 1999, Vol. 32, pp. 75-87.

### About the Authors



**René Fuhlendorff** obtained his MSc in 1989 in organic electro analytical chemistry and physics from the University of Aarhus, Denmark, and partly from University of East Anglia, UK. His professional career began at the Technological Institute, Denmark, where he worked as an analytical chemist and as project manager. In 1994, he became Department Manager at Hedeselskabet with responsibility for various projects, including QA/QC activities. After that Fuhlendorff became Division Manager for Industrial lab activities and later on when the company was integrated in Eurofins Scientific Group, Business Manager at Eurofins Pharma. He played a major role in the development of the Eurofins' business activities, including the work for authorities' and clients' inspections and GMP-approval of the laboratories. In 2008, after nearly 20 years in the laboratory sector, Fuhlendorff decided to do business development for Jurag Separation A/S, where he is Director of Business Development. He is a member of ISPE, BioProcessing Professionals, and Pharma Business Development. He can be contacted by telephone: +45-4816-9608 or by email: rf@jurag.dk.



**Arvid Garde** obtained his MsC in 1997 followed by a PhD in 2002 in the field of electro membrane filtration technology from the Technical University of Denmark (DTU). His cooperation with Jens-Ulrik Rype and Associate Professor Gunnar Jonsson, DTU, within this field resulted in the patented REED technology, upon which the company

Jurag Separation was founded by the three inventors in 2001. He started his professional carrier as Managing Director of Jurag Separation and in 2005, Garde became Technical Director focusing on R&D and implementation of the REED technology. He can be contacted by email: ag@jurag.dk.



**Jens-Ulrik Rype** obtained his MsC in 1997 followed by a PhD in 2002 in the field of electro membrane filtration technology from the Technical University of Denmark (DTU). His cooperation with Arvid Garde and Associate Professor Gunnar Jonsson, DTU, within this field resulted in the patented REED technology, upon which the company Jurag Separation

was founded by the three inventors in 2001. He started his professional carrier as a Product Developer for Immunolex, and later AntiBodyShop, before he returned to a position as Project Manager for Jurag Separation with responsibility for product development and development projects. He can be contacted by email: jur@jurag.dk.

Jurag Separation A/S, Gydevang 4, Allerød DK-3450, Denmark. 

This article presents the methods and results from performing Working Height Velocity studies in conventional cleanrooms.

# Working Height Velocity Measurement in Conventional Cleanrooms

by William Mason, Bernard McGarvey, PhD,  
Thomas R. Spearman, PE

## Introduction

In conventional pharmaceutical cleanrooms, Unidirectional Air Flow (UAF) hoods provide air flow to protect critical (e.g., aseptic) operations from contaminants. The UAF hood air flow patterns are tested using visible particles such as theatrical fog (smoke) to ensure air flows from the cleanest (critical) areas to less clean areas. Routine velocity measurements are taken at the High Efficiency Particulate Air (HEPA) filter protective grill and at working height to ensure the air flow pattern is maintained.

Measuring WHV is a regulatory concern for conventional cleanrooms used in parenteral manufacturing. The following paragraph is from the US FDA Guidance for Industry.<sup>1</sup>

HEPA filter leak testing alone is insufficient to monitor filter performance. It is important to conduct periodic monitoring of filter attributes such as uniformity of velocity across the filter (and relative to adjacent filters). Variations in velocity can cause turbulence that increases the possibility of contamination. Velocities of unidirectional air should be measured 6 inches from the filter face and at a defined distance proximal to the work surface for HEPA filters in the critical area. Velocity monitoring at suitable intervals can provide useful data on the critical area in which aseptic processing is performed. The measurements should correlate to the velocity range established at the time of in situ air pattern analysis studies.

The following paragraph is from the European Medicines Agency (EMA) Annex 1.<sup>2</sup>

Grade A: The local zone for high risk operations, e.g., filling zone, stopper bowls, open ampoules and vials, making aseptic

connections. Normally, such conditions are provided by a laminar air flow work station. Laminar air flow systems should provide a homogeneous air speed in a range of 0.36 to 0.54 m/s (guidance value) at the working position in open cleanroom applications.

Manufacturers have received inspection observations regarding WHV.

1. "In parenteral products manufacturing, the air velocity testing of HEPA filters in critical, (Class 100) areas, is done 4 to 6 inches from the filter face and not at the critical working level where sterile product is open to the environment."
2. "The firm has not performed any studies under dynamic conditions to show there is a correlation between air velocity at the filter face and velocity at the critical working area."

To resolve the observations, several technical studies and industry benchmarking were performed. Earlier technical studies measured air velocity using an electronic manometer and self-averaging pitot array. This instrument has an air velocity accuracy of  $\pm 3\%$  of reading  $\pm 7$  feet per minute (fpm) [0.036 meters per second (m/s)] from 50 to 2500 fpm (0.25 to 12.7 m/s).<sup>3</sup> This instrument also is used to measure High Efficiency Particulate Air (HEPA) filter air velocity during Preventive Maintenance (PM) execution.

The previous technical studies' conclusions were:

- Data included a significant number of velocity readings below 50 fpm (0.25 m/s), which is below the measurable range of the electronic manometer and self-averaging pitot array.
- Individual WHV readings are heavily de-

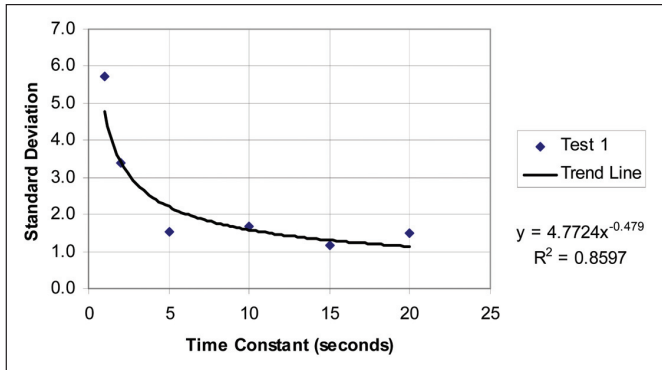

Figure 1. Time constant effects.

pendent upon the geometric shape of the items within the critical area.

- Small position changes in the X – Y – Z planes cause significant variation in the individual readings.

Industry benchmarking with eight pharmaceutical firms and three cleanroom certifiers was performed from June 2005 to February 2006. The benchmarking revealed:

- Most pharmaceutical firms do not measure WHV. Some firms measure WHV during initial qualification, but very few re-measure on a routine basis.
- When WHV readings were measured, acceptance criteria was not established.
- Experience shows that “WHV is not something that can be repeated reliably.”
- The ‘gold standard’ remains Air Flow Pattern Testing (AFPT) correlated to filter face velocities. The filter face velocities are tested routinely, at least every six months. AFPT is repeated when significant changes are made and on a routine schedule, from every one to three years.

Since the previous studies had a significant number of velocity readings below the measurable range of the electronic manometer and self-averaging pitot array, a thermal anemometer was selected for its capability to measure low velocities. This report shares the results of the testing performed with the thermal anemometer.

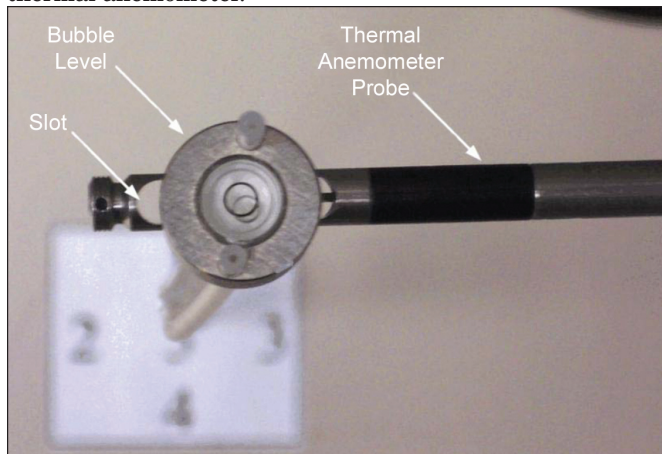

Figure 3. Bubble level.

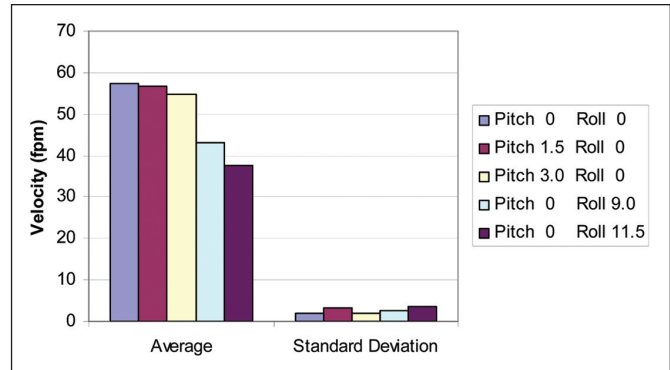

Figure 2. Probe alignment effects.

## Meter Performance

### Theory of Operation

“The thermal (hot-wire or hot-film) anemometer consists of a heated RTD, thermocouple junction, or thermistor sensor constructed at the end of a probe. It is designed to provide a direct, simple method of determining air velocity at a point in the flow field. The probe is placed into an airstream, and air movement past the electrically heated velocity sensor tends to cool the sensor in proportion to the speed of the airflow. The electronics and sensor are commonly combined into a portable, hand-held device that interprets the sensor signal and provides a direct reading of air velocity in either analog or digital display format.”<sup>4</sup>

The thermal anemometer used has a range of 0 to 9999 fpm (0 to 50 m/s); an accuracy of  $\pm 3\%$  of reading or  $\pm 3$  fpm ( $\pm 0.015$  m/s), whichever is greater; and a resolution of 1 fpm (0.0051 m/s).<sup>5</sup>

### Time Constant Effects

The effect of the thermal anemometer time constant was tested using a UAF hood protecting a capping line accumula-

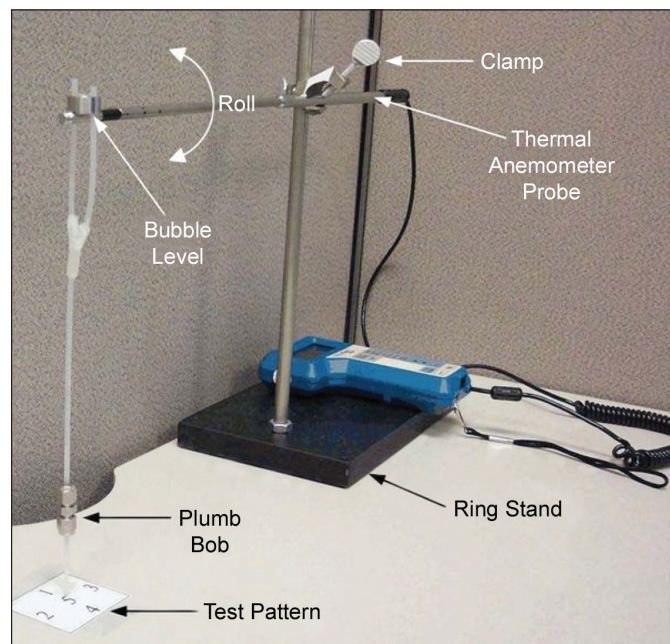

Figure 4. Test setup.

tor table. The time constant is the averaging period of the air flow velocity measurement. The probe was placed 18 inches [45.7 centimeters (cm)] from the HEPA filter protective grill. The anemometer probe was held using a ring stand and was visually aligned. The air flow velocity was approximately 100 fpm (0.51 m/s). Ten readings were taken for each time constant setting of 1, 2, 5, 10, 15, and 20 seconds. The test results comparing the time constant settings to the standard deviations of the 10 readings are shown in Figure 1. Based on these results, a time constant of 10 seconds was chosen for subsequent testing. This time constant achieves good results when balanced against the time required for execution.

## Alignment Effects

The effect of the probe alignment was tested using the thermal anemometer under a UAF hood protecting a capping line accumulator table. The probe was placed 30 inches (76.2 cm) from the HEPA filter protective grill. The anemometer probe was held using a ring stand. A time constant of 10 seconds was used. The air velocity was approximately 60 fpm (0.30 m/s). Ten readings were taken for each probe orientation. The probe orientations tested were a roll of 0, 9, and 11.5 degrees with a pitch of 0 degrees, and a pitch of 1.5 and 3 degrees with a

roll of 0 degrees. The test results comparing the average and standard deviation for each test are shown in Figure 2.

The probe roll alignment effects are apparent in the lower average readings and the higher standard deviations. Based on these results, a method of assuring the proper roll alignment is critical to obtaining consistent measurements. The probe pitch alignment has very little effect.

A bubble level tool, shown in Figure 3, was developed for roll alignment. The bubble level includes a groove that fits in the anemometer probe slot. The ring stand clamp aligns the probe for pitch.

## Test Setup

The test setup subsequently used is shown in Figure 4. The plumb bob is used to determine the location of the velocity measurement in relation to a horizontal plane. The horizontal plane is parallel to the face of the UAF Hood HEPA filter protective grill. This test setup measures the vertical component of air velocity.

## Air Flow Testing

### Obstructed and Unobstructed Air Flow

These tests were executed using an autoclave UAF hood. A

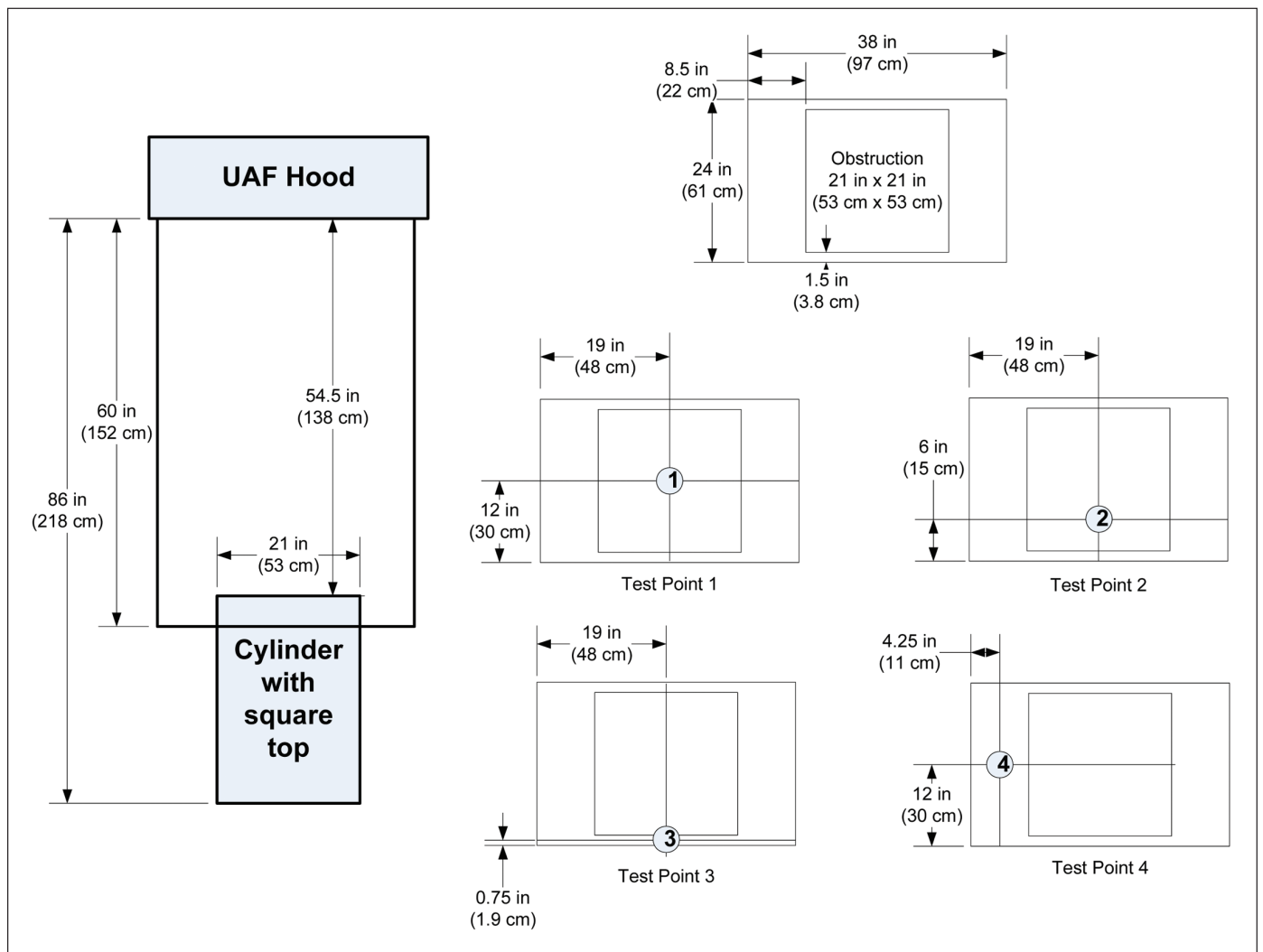

Figure 5. Test locations and setup.

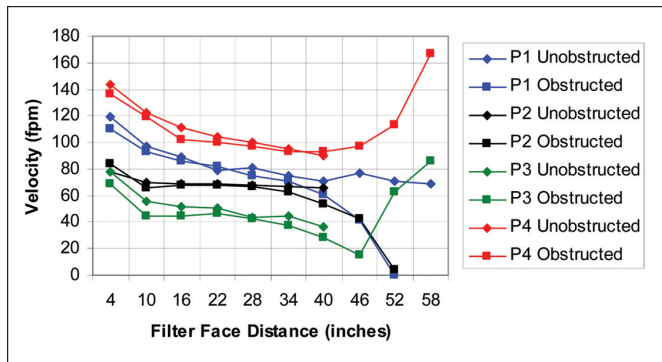

Figure 6. Obstructed and unobstructed air flow.

simulated wind tunnel was created around one HEPA filter using semi-rigid material. The wind tunnel was 60 inches (152.4 cm) in length. Readings were taken at varying distances from the filter face, with and without an obstruction inserted into the air stream. The obstruction was a solid cylinder with a square top surface. Figure 5 shows the test setup and the test point locations. On the 38 inch (96.5 cm) lengths, the filter framing reduced the filter surface area by 1.75 inches (4.45 cm) on each end; therefore, there is no air flow at the wider side edges. The test results are shown in Figure 6.

Figure 6 shows the air velocities at each test point, with and without the obstruction. For the four test points, the obstructed and unobstructed air velocities do not diverge until

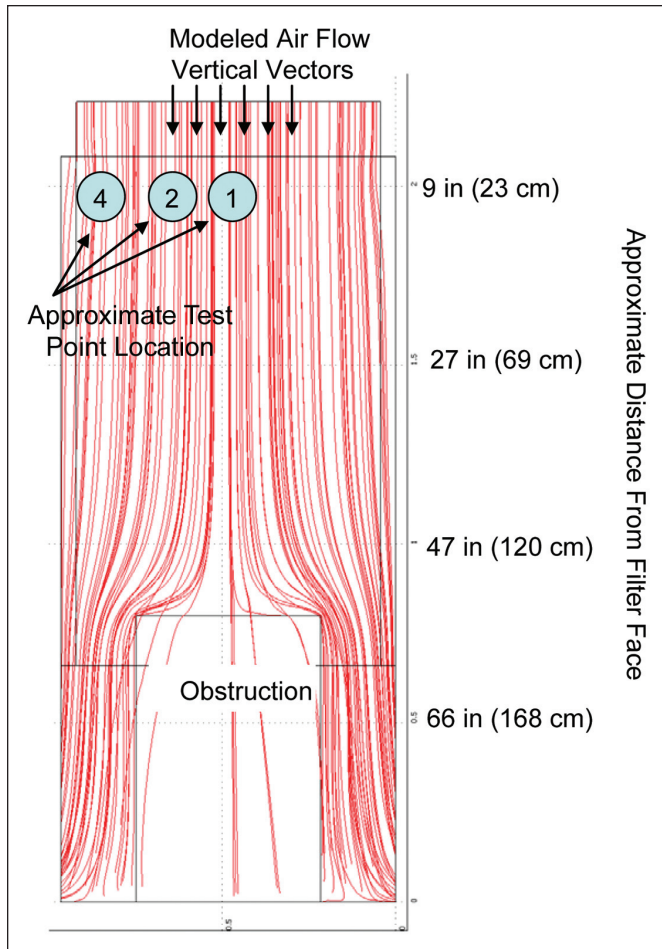

Figure 7. CFD model of obstructed air flow.

40 inches (101.6 cm) from the filter face. The P1 Obstructed velocity begins diverging from the P1 Unobstructed velocity at 40 inches (101.6 cm) from the filter face. The P1 Obstructed velocity reaches 0 fpm (0 m/s) at 52 inches (132.1 cm) from the filter face. This reflects the air flow changing direction from vertical to horizontal as it nears the obstruction surface.

As supporting data a Computational Fluid Dynamics (CFD) model of the testing was created. Figure 7 shows the model results. At Test Point 1 and Test Point 2, the streamlines indicate more horizontal components at 47 inches (119.4 cm) from the filter face, indicating the velocity changing from vertical to horizontal as the air nears the obstruction surface.

The P3 Obstructed and P4 Obstructed velocities begin to increase at 46 inches (116.8 cm) from the filter face until the last test point at 58 inches (147.3 cm). This reflects that the locations where air can escape show an increase in velocity. Figure 8 indicates the CFD model also reflects this air flow behavior by showing the increased number of streamlines accumulating at Test Point 4, as they approach the obstruction, resulting in an increased velocity.

## Working Height Velocity Procedure Considerations

The following considerations were used to determine routine WHV measurement locations and acceptance criteria.

Sample site locations (critical points) are selected based on but not limited to the following criteria:

- microbial dispersion patterns (e.g., personnel traffic, material flow, airflow)
- potential for microbial contamination during actual production
- potential to impact product quality
- monitoring location to allow for reproducible sampling

Technical studies are performed to determine the low and high WHV limits for each critical point location. The studies must ensure that:

- Testing is performed using a thermal anemometer.
- Testing is performed with the UAF hood set at low, nominal, and high velocities. The velocities are based on the UAF hood acceptance limits established by AFPT.
- The HEPA filter face velocity readings are within tolerance before testing.

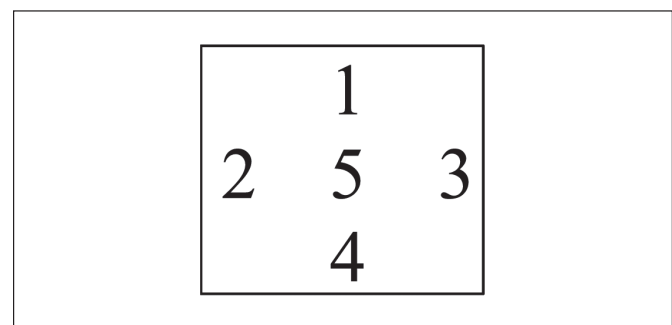

Figure 8. Test location pattern.

- The Heating Ventilation and Air-Conditioning (HVAC) system serving the area, as well as differential pressures, are functioning normally.
- Testing includes taking 10 velocity readings at the critical point to obtain a reasonable sample set to account for measurement variability.
- Sampling, including equipment setup between each test run, is repeated three times to account for any variability in equipment setup and alignment.
- Test points are 12 inches (30.5 cm) above the working surface.
- All data values used to determine acceptance limits reflect conditions representing acceptable airflow patterns.

## Case Study

As a case study for developing WHV acceptance criteria, the following shows the testing application for three locations.

### Tests Executed

Testing was performed with the UAF hood set at low, nominal, and high velocities for AFPT. All three settings were ultimately determined to provide acceptable air flow patterns. The testing included taking 10 readings around the critical point (point 5) in the test pattern plan view shown in Figure 8. The test pattern also is shown in Figure 4. The thermal anemometer probe was placed 12 inches (30.5 cm) above the work surface. A plumb bob, shown in Figure 4, is used to align the anemometer probe above the test point.

Generally, at each velocity setting, two tests were executed at each of the points shown in Figure 8 and three additional tests at the critical location (point 5) only. Testing was executed at three test locations identified as:

- Area A – Accumulator
- Area B – Filler
- Area C – Stopper Bowl

### Test Conditions

No differential pressure alarms or HVAC system issues were encountered during testing. The HEPA filter face velocities that comprised the Air Flow Pattern Testing (AFPT) low, nominal, and high velocity settings are shown in Table A. The HEPA filter face air velocity was measured using an electronic manometer and self-averaging pitot array.

### Results for Individual Tests

The following tables contain the velocity readings used to establish WHV acceptance criteria. Acceptance criteria are only calculated for the critical point (point 5). The data collected at the other points is supplied as reference to help in

Test Area	Low	Nominal	High
A	98 fpm (0.50 m/s)	122 fpm (0.62 m/s)	147 fpm (0.75 m/s)
B	97 fpm (0.50 m/s)	116 fpm (0.59 m/s)	146 fpm (0.74 m/s)
C	98 fpm (0.50 m/s)	118 fpm (0.60 m/s)	142 fpm (0.72 m/s)

Table A. AFPT low, nominal, and high settings.

understanding the variability due to a 3 inch (7.6 cm) difference in test locations.

The data for this area does not follow a logical pattern of values where the high velocity setting is greater than the nominal velocity followed by the low velocity. For this area, all the velocities at the critical point A-5 are essentially the same. The characteristics of Area A with a 75% enclosed area and a significant physical feature to obstruct the air flow may account for the inconsistency in readings. The high standard deviations of 1.7 to 10.9 fpm (0.009 to 0.055 m/s) and variability in readings are a measure of this inconsistency.

The data for this area follows a logical pattern; however, the inconsistency in readings is significant. The logical pattern of values where the high velocity setting is greater than the nominal velocity followed by the low velocity is present. The characteristics of Area B with a 50% enclosed area and a significant physical feature to influence air pattern may account for the inconsistency in readings. The standard deviations from 1.5 to 4.9 fpm (0.008 to 0.025 m/s) and variability in readings are a measure of this inconsistency.

The data for this area shows the maximum velocity setting being equal to the nominal velocity and both just slightly greater than the minimum velocity. Variability in readings is significant. The characteristics of Area C with a 50% enclosed area and a significant physical feature to influence air pattern may account for the inconsistency in readings. The high standard deviations from 1.2 to 8.7 fpm (0.0061 to 0.044 m/s) and variability in readings are a measure of this inconsistency.

### General Conclusion

These results indicate the average values and variability are influenced by physical features or adjacent environments. Although the areas are relatively well enclosed by corrugated polycarbonate sheets, the consistent physical obstructions appear to be causing significant variability in the readings.

### Establishing Criteria for Working Height Velocity Measurements

Statistical analysis software was used to calculate WHV acceptance criteria using the data from Tables B, C, and D. Based on acceptable AFPT results, all readings recorded represent acceptable WHV values. To view and determine these results, a histogram is supplied for each critical location with the Quantiles showing the minimum and maximum values.

The WHV acceptance criteria from the histograms in Figures 9 to 11 is summarized in Table E.

### Potential Causes for Failure

In the event readings are outside the acceptance criteria, several potential causes should be investigated. These include:

1. Test location
2. Test method
3. HEPA filter velocities
4. Adjacent area



Average					Standard Deviation					Velocity Setting
A-1	A-2	A-3	A-4	A-5	A-1	A-2	A-3	A-4	A-5	
59.0 (0.30)	52.0 (0.26)	45.9 (0.23)	31.6 (0.16)	49.9 (0.25)	2.4 (0.012)	4.5 (0.023)	7.2 (0.037)	7.9 (0.040)	6.0 (0.030)	Low
62.0 (0.31)	54.5 (0.28)	47.7 (0.24)	38.6 (0.20)	53.9 (0.28)	1.7 (0.009)	4.8 (0.024)	3.9 (0.020)	7.2 (0.037)	3.0 (0.015)	Low
				54.4 (0.28)					4.2 (0.021)	Low
				54.8 (0.28)					3.4 (0.017)	Low
				52.8 (0.27)					3.6 (0.018)	Low
				41.5 (0.21)					3.7 (0.019)	Low
				40.2 (0.20)					8.8 (0.045)	Low
				41.5 (0.21)					4.8 (0.024)	Low
				43.7 (0.22)					4.9 (0.025)	Low
				37.8 (0.19)					7.2 (0.037)	Low
65.4 (0.33)	44.3 (0.23)	37.7 (0.19)	21.2 (0.11)	44.2 (0.22)	2.7 (0.014)	7.8 (0.040)	5.3 (0.027)	5.4 (0.027)	7.7 (0.039)	Nominal
				52.2 (0.27)					5.6 (0.028)	Nominal
				45.8 (0.23)					7.6 (0.039)	Nominal
				49.4 (0.25)					5.7 (0.029)	Nominal
				45.7 (0.23)					7.3 (0.037)	Nominal
74.1 (0.38)	36.6 (0.19)	50.2 (0.26)	29.3 (0.15)	41.1 (0.21)	2.1 (0.011)	8.9 (0.045)	9.1 (0.046)	5.1 (0.026)	10.9 (0.055)	High
69.5 (0.35)	64.5 (0.33)	43.9 (0.22)	13.7 (0.07)	40.6 (0.21)	3.6 (0.018)	6.6 (0.034)	4.1 (0.021)	6.5 (0.033)	6.6 (0.034)	High
				37.3 (0.19)					9.9 (0.050)	High
				47.8 (0.24)					6.4 (0.033)	High
				50.3 (0.26)					7.7 (0.039)	High

Table B. Area A results in fpm (m/s).

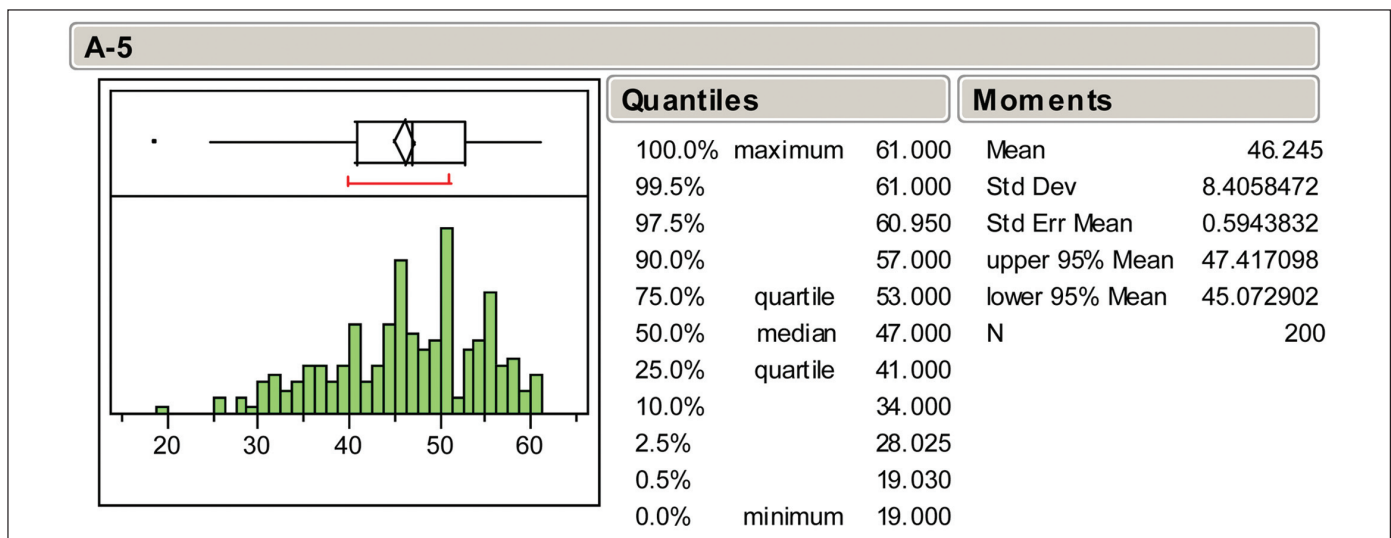

Average					Standard Deviation					Velocity Setting
B-1	B-2	B-3	B-4	B-5	B-1	B-2	B-3	B-4	B-5	
20.6 (0.10)	12.9 (0.07)	30.8 (0.16)	30.4 (0.15)	25.5 (0.13)	2.8 (0.014)	3.3 (0.017)	1.8 (0.009)	2.4 (0.012)	3.7 (0.019)	Low
26.5 (0.13)	16.4 (0.08)	32.2 (0.16)	28.8 (0.15)	24.7 (0.13)	3.6 (0.018)	4.2 (0.021)	1.5 (0.008)	2.3 (0.012)	4.9 (0.025)	Low
				27.3 (0.14)					2.7 (0.014)	Low
				24.3 (0.12)					3.6 (0.018)	Low
				27.8 (0.14)					3.1 (0.016)	Low
				30.7 (0.16)					2.9 (0.015)	Low
				30.6 (0.16)					1.7 (0.009)	Low
				30.7 (0.16)					3.5 (0.018)	Low
				30.5 (0.15)					3.2 (0.016)	Low
				31.3 (0.16)					3.9 (0.020)	Low
27.3 (0.14)	15.1 (0.08)	37.7 (0.19)	38.2 (0.19)	33.5 (0.17)	3.4 (0.017)	3.6 (0.018)	2.1 (0.011)	2.7 (0.014)	4.0 (0.020)	Nominal
				31.8 (0.16)					3.6 (0.018)	Nominal
				32.3 (0.16)					2.3 (0.012)	Nominal
				33.3 (0.17)					2.5 (0.013)	Nominal
				34.1 (0.17)					1.7 (0.009)	Nominal
35.2 (0.18)	15.7 (0.08)	46.7 (0.24)	43.2 (0.22)	38.0 (0.19)	2.6 (0.013)	3.6 (0.018)	1.6 (0.008)	2.7 (0.014)	2.2 (0.011)	High
35.0 (0.18)	15.5 (0.08)	45.9 (0.23)	43.8 (0.22)	34.6 (0.18)	2.1 (0.011)	2.4 (0.012)	1.9 (0.010)	2.3 (0.012)	2.7 (0.014)	High
				39.0 (0.20)					3.5 (0.018)	High
				39.6 (0.20)					2.2 (0.011)	High
				40.4 (0.21)					2.3 (0.012)	High

Table C. Area B results in fpm (m/s).

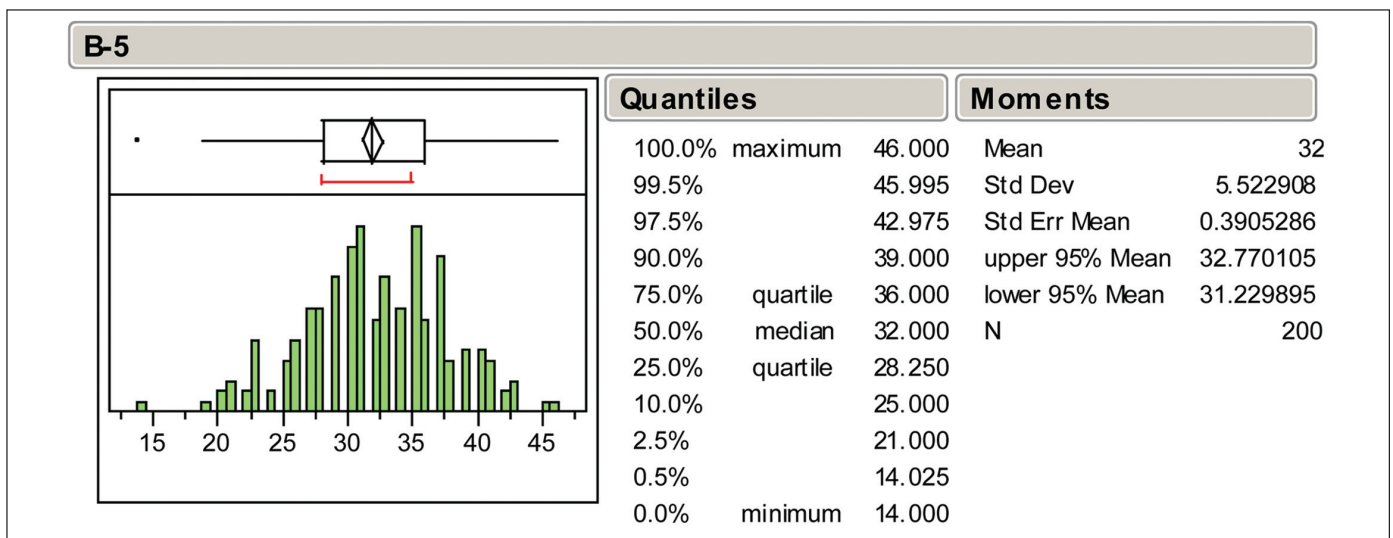

Figure 10. Area B histogram.

# Working Height Velocity Studies

Average					Standard Deviation					Velocity Setting
C-1	C-2	C-3	C-4	C-5	C-1	C-2	C-3	C-4	C-5	
22.1 (0.11)	31.0 (0.16)	4.2 (0.21)	14.6 (0.074)	21.5 (0.11)	2.5 (0.013)	5.2 (0.026)	1.3 (0.0066)	3.9 (0.020)	2.2 (0.011)	Low
				22.9 (0.12)					3.8 (0.019)	Low
				21.3 (0.11)					3.2 (0.016)	Low
				23.0 (0.12)					1.2 (0.0061)	Low
				22.5 (0.11)					3.8 (0.019)	Low
				21.0 (0.11)					3.6 (0.018)	Low
				23.8 (0.12)					5.5 (0.028)	Low
				18.4 (0.093)					3.2 (0.016)	Low
				20.4 (0.10)					4.0 (0.020)	Low
				21.1 (0.11)					3.2 (0.016)	Low
31.1 (0.16)	39.7 (0.20)	26.3 (0.13)	30.4 (0.15)	24.1 (0.12)	5.0 (0.025)	5.8 (0.029)	3.3 (0.017)	5.4 (0.027)	2.3 (0.012)	Nominal
				24.4 (0.12)					2.5 (0.013)	Nominal
				26.5 (0.13)					3.2 (0.016)	Nominal
				25.9 (0.13)					2.1 (0.011)	Nominal
				26.4 (0.13)					4.8 (0.024)	Nominal
38.8 (0.20)	51.2 (0.26)	28.9 (0.15)	29.9 (0.15)	22.4 (0.11)	8.7 (0.044)	4.2 (0.021)	3.4 (0.017)	5.9 (0.030)	2.3 (0.012)	High
33.5 (0.17)	46.1 (0.23)	28.6 (0.15)	29.4 (0.15)	23.0 (0.12)	2.6 (0.013)	4.9 (0.025)	5.2 (0.026)	6.2 (0.031)	3.2 (0.016)	High
				28.6 (0.15)					2.6 (0.013)	High
				27.6 (0.14)					3.2 (0.016)	High
				24.6 (0.12)					2.0 (0.010)	High

Table D. Area C results in fpm (m/s).

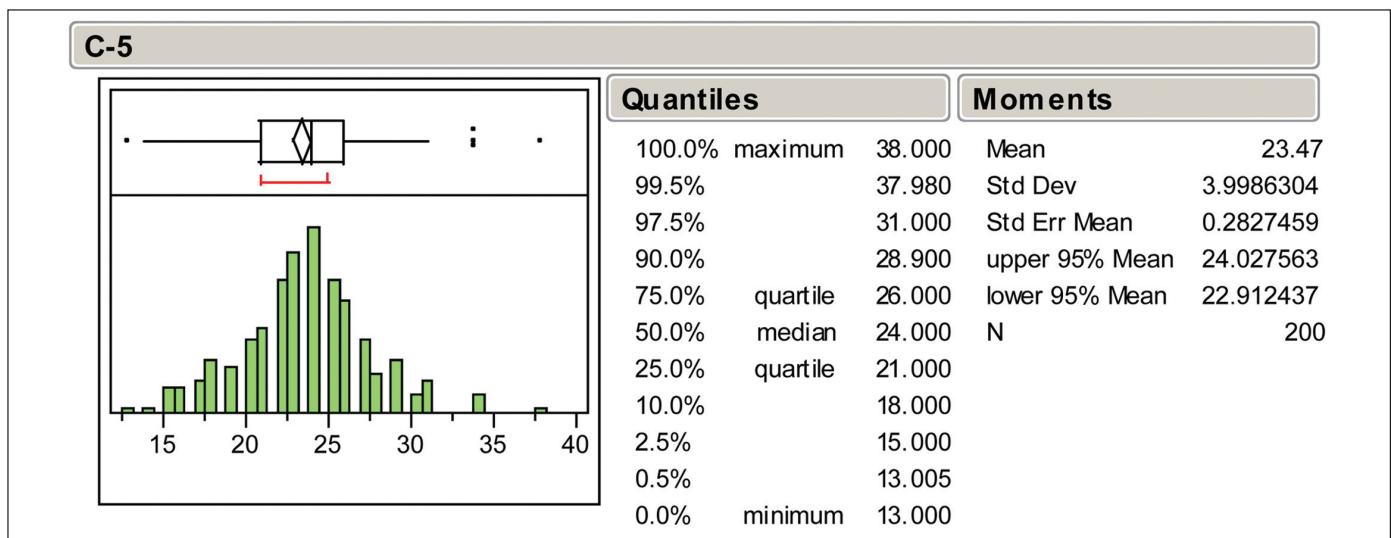

Figure 11. Area C histogram.

Critical Point	Minimum Air Velocity	Maximum Air Velocity
A - Accumulator	19 fpm (0.097 m/s)	61 fpm (0.31 m/s)
B - Filler	14 fpm (0.071 m/s)	46 fpm (0.23 m/s)
C - Stopper Bowl	13 fpm (0.066 m/s)	38 fpm (0.19 m/s)

Table E. Case study WHV acceptance criteria.

Verification that the critical point tested matched the test location in the technical study should be confirmed. Critical elements of the test method include the anemometer time constant and probe alignment. The HEPA filter face velocities will affect the working height velocities. The velocities of the HEPA filters were recorded from the AFPT that preceded the WHV testing. Subsequent adjustments to these velocities can impact WHV readings. All tests used to determine the critical limits were executed with corrugated polycarbonate sheet doors closed.

## Conclusions

1. Velocity can vary significantly with relatively small location change. This is especially important using thermal anemometers.
2. Velocity measurements at the HEPA filter protective grill are a better indicator of UAF hood performance than velocity measurements at working height due to the high standard deviation and variability in velocity readings at the working height. The correlation of HEPA filter face velocity to air flow pattern testing is a more reliable and repeatable method than the correlation of working height velocity to air flow pattern testing.
3. Thermal anemometry can be used to obtain detailed multi-directional spatial variation of air flow velocities in complex flow environments. Also, it provides data that can be used to compare with CFD models.

## References

1. *Sterile Drug Products Produced by Aseptic Processing – Current Good Manufacturing Practice, Food and Drug Administration*, 2004, p.9.
2. *EC Guide to Good Manufacturing Practice Revision to Annex 1 – Manufacture of Sterile Medicinal Products*, European Commission, 2008, p. 2.
3. Shortridge Airdata™ Multimeter Electronic Micromanometer with Velgrid, Model ADM-880C, “Specifications,” February 2007, page 2.
4. *2005 ASHRAE Handbook – Fundamentals*, page 14.15.
5. TSI VELOCICALC® Plus Air Velocity Meter Model 8384 /8384A/8385/8385A/8386/8386A, “Operation and Service Manual,” P/N 1980321, Revision H, June 2006, page 21.

## Acknowledgments

The contributions of the following people to the development of this technical report are greatly appreciated:

Beverly K. Flick  
 John W. Masengale  
 Peter K. Meginnis, PE  
 Donald R. Moore, PE  
 Douglas A. Schrader

## About the Authors

**William G. Mason** is an Engineering Consultant with Eli Lilly and Company. Since joining Lilly in 1989, he has held a variety of assignments in technical services, process control and automation, and process engineering. He can be contacted by telephone: +1-317-277-7350 or by email: mason\_william\_g@lilly.com.



**Bernard McGarvey, PhD**, is an Engineering Advisor with Eli Lilly and Company. Currently, he leads a group that focuses on the use of modeling within manufacturing and process development. This group applies process modeling to such diverse areas as capacity simulation, flowsheet modeling, computational fluid dynamics, optimization, and operations research. He has 25 years of experience in the pharmaceutical industry and has held previous positions in technical services, process control and automation, and process engineering. He can be contacted by telephone: +1-317-433-2293 or by email: bmcg@lilly.com.



**Thomas R. Spearman, PE** is an Associate Engineering Consultant at Eli Lilly and Company. Since joining Lilly in 1978, he has held a variety of engineering assignments and is currently the responsible engineer for facilities, HVAC, and utility systems in Indianapolis Parenteral Operations. He also leads the global Parenteral HVAC Technology Team. He obtained a BSc in mechanical engineering from Purdue University at Indianapolis. He obtained his professional engineering license in Indiana in 1998. He is a member of ISPE and is a member of the ISPE Sterile Products Processing Community of Practice (COP) Steering Committee. He is a member of the American Society of Heating, Refrigerating and Air-Conditioning Engineers (ASHRAE) and is a corresponding member of the ASHRAE Clean Space Technical Committee. He was a member of the Board of Directors of the Controlled Environment Testing Association (CETA) from 2005 to 2008. He can be contacted by telephone: +1-317-276-8750 or by email: t.spearman@lilly.com.

Eli Lilly and Company, Lilly Corporate Center, Indianapolis, Indiana 46285, USA. 

This article presents an overview of the planning of an API production factory from the risk assessment viewpoint. Three risk assessment factors of severity, probability of occurrence, and detectability are discussed. An example of conceptual layout planning is presented.

## A Risk Assessment Approach to Planning an API Production Factory

by Kazuo Tozaki

### Introduction

A long period of time and many steps are necessary to plan and construct an API production plant (Figure 1). Of particular concern is the construction of the hardware that goes into the plant. The results of design work during the basic planning and/or basic design phase play a key role in determining the ultimate cost of the plant.

This article will summarize important items to be considered and the process to be followed in the early stages of planning an API production facility that qualify it in terms of GMP.

The main discussion will center around the risk assessment approach of how to give shape to the GMP concept from the viewpoint of contamination control for the API production process. For the purposes of this discussion, the product is assumed to be a chemically synthesized non-aseptic API.

### Contamination Risk in the API Production Process

During the production of API, control measures like process control and quality control are employed in order to build quality-creating factors into the process steps, with the aim

of maintaining API specific qualities, namely, equivalency, efficacy, quality, purity, and safety. But, as is well known, many contamination risks exist in the API production process - *Figure 2*. The significance of these contamination risks lies in the fact that they constitute threats to the maintenance of the desired API specific qualities. The materials that pose a hazard and the mechanisms of occurrence of contamination are the main features of these risks.

### Risk Assessment and Assessment Factors of Contamination

ICH Q9 presents a typical example of a quality risk management process and explains that risk is generally understood as the combination of the assessment factors, that is, the probability of occurrence of harm and the severity of the harm. It also includes a reference to a 'Failure Mode Effect and Criticality Analysis' (FMECA), which incorporates "detectability" (the ability to detect the presence of contamination) as an additional factor. According to this idea, risk will be expressed as a combination of the risk factors, that is, the severity of harm, the probability of occurrence, and the detectability of contamination.

Figure 1. Schematic diagram of the project flow for the construction of an API production facility.

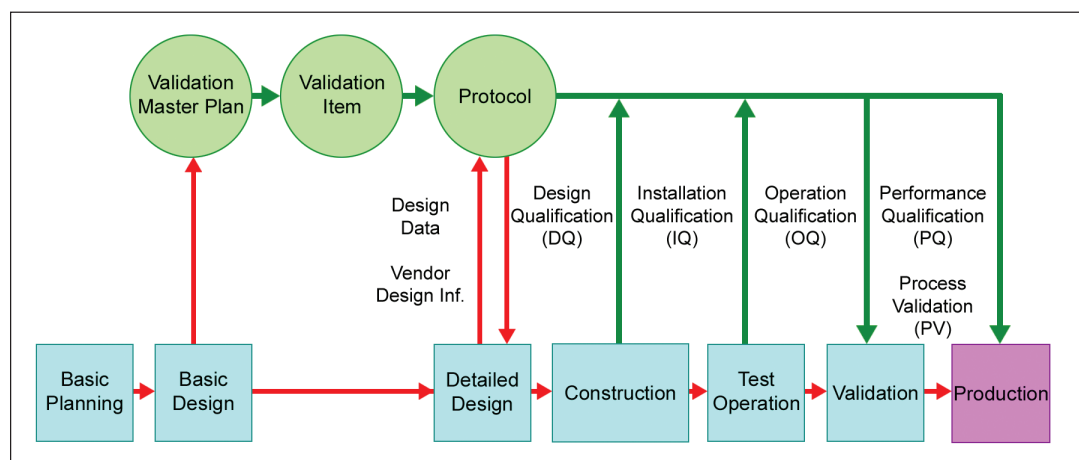

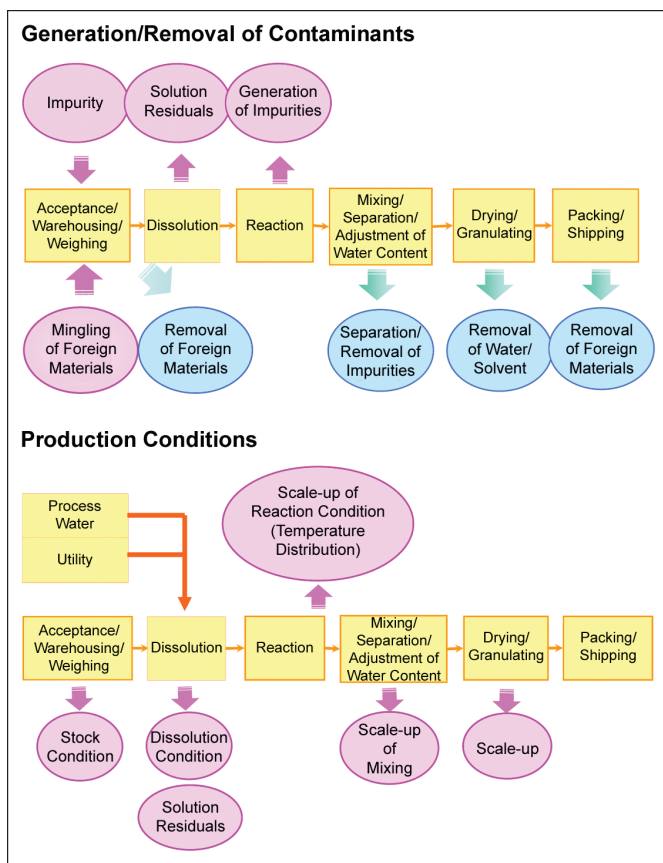

Figure 2. Contamination risks in the API production process.

$$\text{Risk} = \text{Severity of Harm} \times \text{Probability of Occurrence} \times \text{Detectability}$$

These factors may be combined as the product, the sum of the elements, or in the form of a matrix. The form selected should be decided upon on a case-by-case basis. The following are the important elements to be aware of in order to assess the risk factors.

## Severity of Harm

Severity is assessed by the potential magnitude of the harm that will be caused. The harm which can be brought about due to the occurrence of contamination includes, for example, the delays in production owing to the reprocessing work, disposal of the batch, the impact on other products, and the occurrence of drug-induced ill-effects resulting from use of the product.

In order to assess the magnitude of harm, understanding the significance of the production process that will suffer contamination by evaluating the materials being handled and the process steps will be of key importance. Assessing the impact of the contamination on the materials handled will include:

- Evaluating the impact on the specific qualities of the API:
  - Finding the status of the materials handled, such as raw materials (chemical substances), API starting materi-

als, intermediate materials, significant intermediate materials, and final intermediate materials.

The impact of any contamination will differ according to the stage in the process at which the contamination takes place.<sup>Note 1</sup>

## Probability of Occurrence

It is difficult to evaluate the probability of occurrence quantitatively. However, it becomes easier to understand if it is considered as being divided into two parts, that is, the nature of the contamination threat (causes difficulty in the event of occurrence) and the fragility of the production facility (weakness of the production facility).

The mechanism of the contamination threat is considered as including phenomena, such as generation, growth, remaining, mingling, invasion, and cross-contamination.

On the other hand, the fragility is considered to be related to non-conformance with the contamination prevention measures. Accordingly, the occurrence of contamination is considered to be a phenomenon in which the threat of the occurrence of contamination becomes apparent through the trigger represented by the fragility of the production facility and production management system.

The following is an example of the occurrence of contamination. "Waste material on a beam flange drops into the reaction liquid through an open inspection-hole of the reactor and is mixed with the process material, because the inspection-hole is located directly under the beam." The waste material on the beam flange will be the cause of the threat (cause material of harm) and is mixed with the process liquid resulting in the occurrence of the contamination.

The fact that that there was a reactor directly underneath and no protective measures were in place will be the fragility.

The fragility will exist in the hardware elements, such as equipment and facilities and also in software elements, such as rules or a standard operating procedure.

If the situation is left in the present (fragile) condition, it is necessary to assume the possibility of the occurrence of contamination every time the inspection-hole is opened.

The contamination has its own mechanism of occurrence.

Clarification of the mechanisms on a scientific basis and complementing and/or reinforcing of the fragility are necessary.

In the above example, a software-type countermeasure of regularly cleaning the area, including the beam flange, will be one effective way of preventing the occurrence.

Also, as the mechanism of contamination occurrence is considered to be the mingling of the waste material, which has dropped into the opening just beneath the beam, a design change that alters the relative positions of the beam and opening, or action that provides proper protection to the existing opening will remove the threat of contamination.

## Materials Causing Contamination

The types of materials which are viewed as causing the threat of contamination are listed in Figure 3, "Classification of Contaminants and Corresponding Measures."

In Figure 3, the contaminants are classified into three groups of potential contaminants, that is, contaminants related to source control, the contaminants related to protection control, and those involved in cross-contamination.

## Mechanisms of Contamination will include:

- generation, growth, remaining, mingling, invasion, cross-contamination
- defects in the quality control system or the manufacturing control system

The assessment of these mechanisms will need the knowledge of the materials handled and the detailed information about the production facility.

## The Fragility Toward Contamination

Fragility, as shown in Figure 4, will act as a loophole through which the protection measures against the threat are undermined.

Weak points in the process (fragility) are subject to contamination. A variety of hardware/software items in the production process will be related and are summarized as follows:

## Treatment of Raw Materials

- level of quality control at suppliers and the results of audits
- quality of the raw materials received
- effectiveness and performance level of receiving checks
- effectiveness and performance level of warehouse controls

## Physico-Chemical Properties, State, and Characteristics of the Materials Handled

- physico-chemical properties: the sensitivity of the materials handled to changes of process conditions.
- state of materials: powder, wet powder, gas/vapor, liquid
- characteristics: coagulation, adhesiveness, volatility, change in quality, etc.

## Characteristics of the Reaction Process

The difficulty that may exist in controlling the reaction.

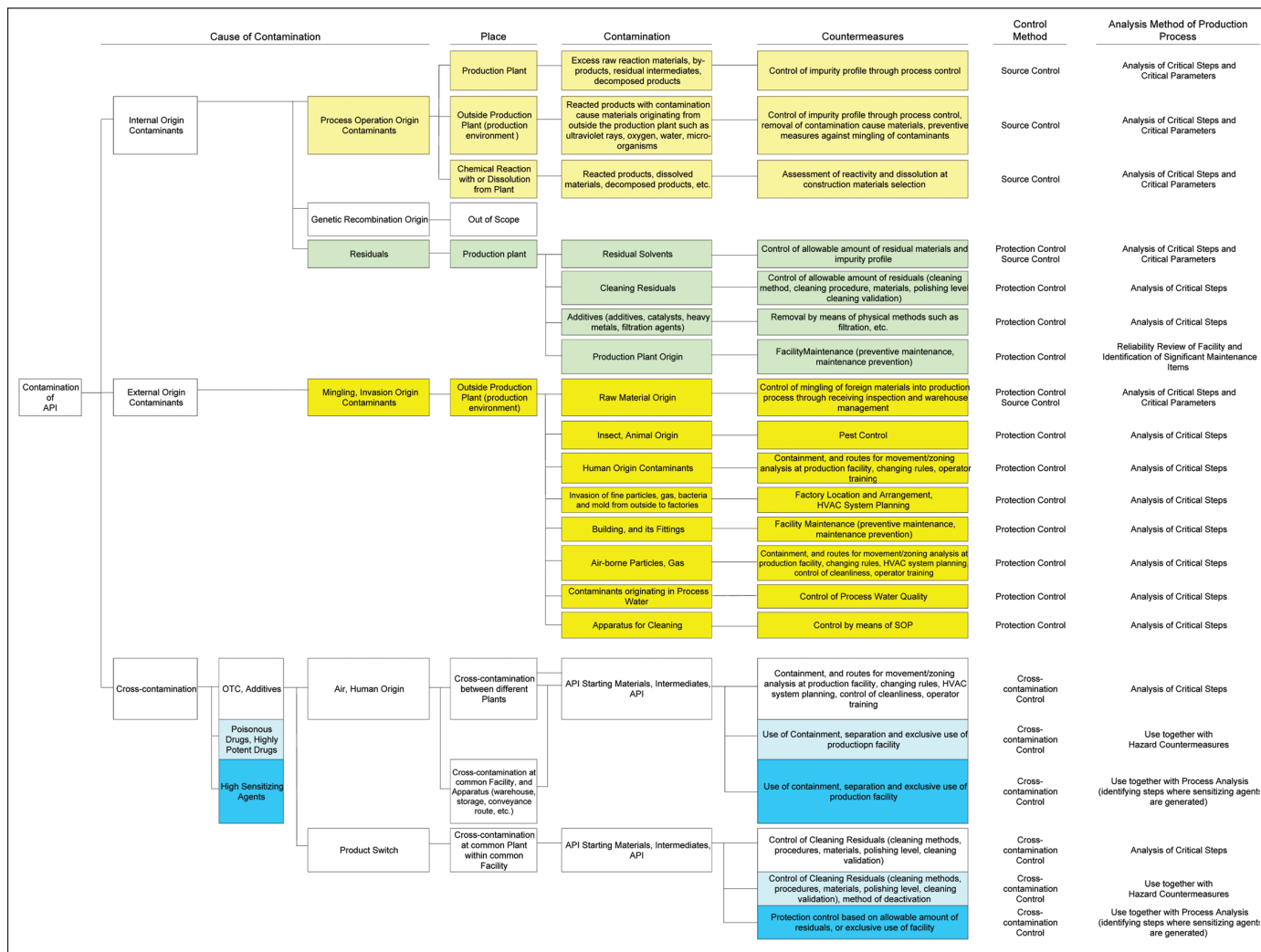

Figure 3. Classification of contaminants and corresponding measures.

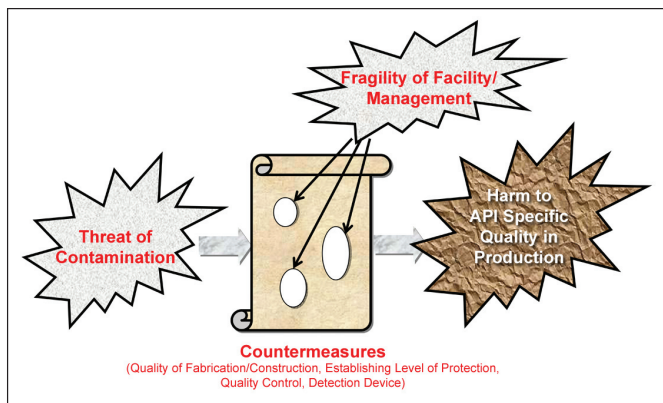

Figure 4. Contamination risks of API.

## Robustness Against Contamination of the Process System

- Whether the contamination affects the quality of the product directly or indirectly will be assessed.
- For example, the contamination of the clean steam or the process water will directly affect API quality, but will affect it indirectly in a case involving jacket cooling water of the reactor.

## Level of Operation exposure to the External Environment

The level of exposure of the operation to the external environment will differ depending upon the operation status, specifically, whether it is in closed operation, in briefly opened operation, in completely opened operation or in common use operation.

## Quality of the Construction/Fabrication of the Facility

The assessment factors for the quality of fabrication or how well-built the facility is have relation to a number of areas, including the level of technology employed and cost performance issues. The typical assessment factors will be: cleanability, ease of washing, ease of overhaul, toughness, corrosion resistance, ease of maintenance, weather-proofing, protection level against the external environment, contamination resistance/self cleaning capacity, operability, safety, etc.

However, the purpose of the facility must be paid careful attention to in actual practice. (For example, the capacity for complete overhaul does not justify itself; it must be assessed in terms of its necessity for the purpose of the facility).

## Process and the Process Devices for Quality Control

The detection process for impurities, the analytical processes applied to monitor the quality of the API and the intermediates, and the process for the confirmation of the completion of the reactions can be raised as examples.

## Facility Maintenance

The maintenance and the quality of the fabrication will be inevitably complementary to each other, otherwise both may be the source of malfunctions.

- level of the facility maintenance
- level of practical application of good work practices (the 5S)<sup>Note 2</sup>
- level of training for operators and its effectiveness
- nature and effectiveness of the measures included in procedures to cope with any instances of nonconformity
- state of preparation of the Standard Operation Procedures are raised as examples

## Conditions of the Surrounding Environment (External to the Equipment)

Given below are well known examples of conditions for which parameters should be set.

- temperature
- humidity
- cleanliness
- ability to withstand the effects of external disturbances

## **Detectability**

Detectability is the ability to discover or determine the existence, presence, or fact of hazards, together with the degree of severity, related to critical quality risk. The waste material on a beam flange may happen to drop into a powder product, not into the liquid in the reactor. In this case, we cannot find the waste materials easily, making detectability low and the risk higher than in the case of liquids.

In the case of liquids, usually we can easily detect and remove the waste with a filter. And we may assume that the severity of harm and probability of occurrence are to be the same level.

The following are important examples of factors that will have significant influence on detectability:

- state of the materials handled (powder, wet powder, liquid, gas/vapor)
- existence of detection mechanisms or detection process steps and their accuracy
- existence of monitoring mechanisms
- position among the production steps (For example, after the final purification step or final sterilization step, there exist no detection mechanisms before shipping inspection.)

## **Countermeasures Against Contamination Risks**

The contamination threat will comprise the occurrence of generation, growth, remaining, mingling, invasion, and cross-contamination, and that fragility will be related to the inappropriateness of the hard and software aspects of the facility. To prevent contamination risks from actually causing harm, it will be necessary to identify the cause materials of contamination, to make clear on a scientific basis the mechanisms of contamination, and to determine the degree of fragility of the facility that may be threatened by contamination. It also will be necessary to take proper countermeasures which are balanced from both the hard- and software standpoints and plan a production facility/system that is resistant to contami-



nation. The above measures enable the construction of the GMP qualified production facility, and through the PDCA cycle of GMP management during the operation phase, GMP will be realized.

The countermeasures to the contamination risk can be summarized in the four steps below:

Step 1 - identify the contaminants

Step 2 - make clear the mechanisms of contamination and evaluate the threat.

Step 3 - evaluate the risk with consideration given to the severity and detectability.

Step 4 - take concrete measures, which are balanced from the viewpoint of hardware/software aspects to reduce the fragility of the production facility.

## Planning Contamination Prevention Measures

The planning of the contamination prevention measures are studied according to the following five policies. During this study, three management concepts of source control, protection control, and hazard control are proposed.

### Classify and Group Contaminants

The source materials of contamination include those from a wide range of origins. Hence, clear classification and grouping will be essential. Therefore, each contaminant is identified and classified according to the cause and place of generation.

A sample of the result of the above classification is shown in Figure 3 in which countermeasures and management policy for each contaminant also are indicated.

The contaminants of API are classified into three groups, the contaminants which originate in the production process (hereinafter referred to as “internal origin contaminants”), the contaminants which originate outside the production process (hereinafter referred to as “external origin contaminants”), and those involved in cross-contamination.

Source control, protection control, and cross-contamination control correspond mainly to each of the types of contaminants mentioned above. In Figure 3, undesired materials<sup>Note 3</sup> also are included as well as the foreign materials that have mingled or invaded from outside of the process. The production facility itself also is included as a source of contaminants.

### Control the Generation and Removal of Contaminants (Source Control)

It is to control the generation and removal of contaminants within the production process.

### Protect the API or Intermediate Product from the Mingling and Invasion of Contaminants (Protection Control)

It is to protect the API or intermediate products from existing contaminants.

### Prevent Cross-Contamination (Cross-Contamination Control)

The contaminants involved in cross-contamination have a relation to the former two types of contaminants.

### Integrate with Hazard Control

In recent years, as the number of new, highly potent drugs has increased rapidly, it is generally acknowledged that not only the protection of the drugs, but also the protection of personnel/the environment are indispensable. So, it is important to incorporate hazard control in order to attain the purpose of “the protection of personnel/external environment” together with the source control, the protection control, and the cross-contamination control, which are to attain “the assurance of drug quality.” Thus, the protection of the drugs from contaminants and the protection of personnel/the environment must necessarily be realized in one set of hardware. A system of anti-hazard countermeasures has been developed that establishes exposure levels based on the safety data like MSDS, and determines the barrier levels that protect operators/the environment from drugs, and is in use for the designing of commercial plants.

The purpose of the contamination control for API is considered to realize the countermeasures against the various contaminants shown in Figure 3 in one facility according to three management factors below in a way which satisfies the hardware/software balance.

## Control of Contaminants

In this paragraph, the outline of the contamination control will be given below according to Figure 3 and three management concepts are detailed.

### Source Control

#### The Analysis of Critical Process Steps<sup>Note 4</sup>

Source control is aimed at maintaining API specific qualities through the control of the generation/removal of undesired materials within the production process. In the case of chemically synthesized API, the impurity profile and the physico-chemical properties are controlled within the established control limits. The strictness of process control is not the same with each process step, because the GMP significance is not

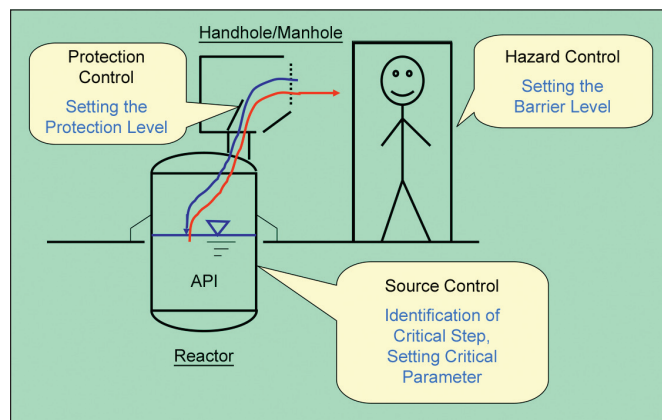

Figure 5. Three management concepts of contamination control.

the same throughout the API production process.

The analysis of critical process steps gives an effective tool for this type of analysis. It enables the classification of the level of control according to the significance of the process step using the concept of critical process steps and critical parameters.

The following process steps are raised in general as the critical process steps.<sup>Note 5</sup> The manufacturer will decide these in detail, while taking into consideration the significance and characteristics of the production process together with the practice of process control.

Through the analysis of critical process steps, the object of control to avoid the threat of contamination – which will be brought about by any deviation, operational mistake, or failure, and the places in the production process where contamination risks exist – will be identified. In order to give shape to the countermeasures against the risks posed by contamination, establishing the level of management required to control the occurrence of contamination based on the evaluation of the degree of harm is necessary. For this reason, establishing the allowable impurity levels, which are the basis of evaluation, is indispensable.

Accordingly, in the source control, establishing the allowable level mentioned above and the process control in order to control the generation/removal of undesired materials is necessary. For the process steps downstream of critical steps, strict control is required.

Some changes with an impact on the API specific qualities established in the development phase are likely. These may be as a result of the increased scale, the altered process conditions, and different surrounding environment as well changes made in the process when the investigational plant is replaced by its commercial successor.

It is desirable to remove the influences of these changes beforehand so that the generation/removal control of the undesired materials will be carried out effectively through the daily operation control and maintenance work during the production phase.

Thus, the verification and documentation ensuring the equivalence<sup>Note 6</sup> will become necessary at the test operation and validation phase.

## *Internal Origin Contaminants*

Internal origin contaminants are classified into two groups: 1. the contaminants which originate in the process unit operation, such as chemical reaction, extraction, cell culture, fermentation, and enzymatic reaction, and 2. the residuals.

Among internal origin contaminants, the contamination which will be generated by genetic recombination is not within the scope of this classification in accordance with the GMP Guide for API (ICH Q7).

### Contaminants which Originate in the Process Unit Operation

These include “the production plant origin contaminants,” which derive from the cause materials in the process plant, “the outside production plant origin contaminants,” which

derive from the cause materials outside the process plant, and “chemical reaction with or dissolution from the production facility.”

### Production Plant Origin Contaminants

These can be defined as undesirable materials, such as excess raw reaction materials, by-product, decomposed product, denatured materials, residual intermediates, and recovered solvent.

Through the control of the generation/removal of these contaminants, the impurity profile will be controlled.

Lot control of the recovered solvent will be carried out so that identification of the solvent used for each lot can be made.

Here, in the case of mixing the solvents between lots, the equivalence of the solvent to be added must be tested and confirmed before it is mixed with the original solvent.

### Outside Production Plant Origin Contaminants

Contaminants may be generated through the chemical reactions involving the API, reaction materials, and intermediates, which will occur by the mingling of or stimulation by the cause materials of contamination, which will come from the production room where the production facility is installed and from outdoors, such as ultraviolet rays, oxygen in the air, water, and micro-organisms, which are well known examples.

In the case of ultraviolet rays, wavelengths will be evaluated as to whether they have a potential contaminating effect or not, and concentrations left behind in the reaction liquid will be evaluated for the amount of contaminants generated.

If necessary, process control limits will be established based on this information in order to contribute to contamination prevention.

### Chemical Reaction With or Dissolution From the Production Facility

Contaminants may be generated through chemical reaction between the raw/reaction materials and the materials used in manufacturing the equipment or by the liquation from the construction materials, e.g., the chemical reaction between raw materials and glass-lined vessels, or trace metals in rubber stoppers, etc. These contaminants are caused by the lack of reliability and conformity with respect to mechanical and material issues of the production equipment against the chemical compound handled.

### Residuals Inside the Production Facility

It is generally well known that residual solvents, residuals left behind after washing, additives, and residuals torn or which have fallen from the production equipment represent a potential contaminant effect. Protective countermeasures will be necessary based upon the significance of the process steps, the dangerousness of the residues, and the ease of removal.

### Residual Solvent

Control through the impurity profile, if necessary, will be carried out, as well as control through the allowable control

limit in order to manage the amount of the residual solvent. The ways of treating residual solvents are different in the case of intermediates and API. In the case of intermediates, their specifications will be established depending upon each case in terms of the impact on their stability, the degree of influence on the next process step or crystallization, and whether it will, if carried over to the API, have a poisonous effect or cause mutagenicity or carcinogenicity, etc. On the other hand, it is required to carry out control of the residuals in the API in accordance with “Impurities: Guideline for Residual Solvents”(ICH Q3C).

## Cleaning Residuals

The examples are:

- residuals left behind in the reactors or vessels after between-lot-cleaning
- residuals on the filters of a centrifuge, the use of which extends over several lots
- cleaning residuals left following a product switching operation
- cleaning residuals at product switching operation for producing several intermediates in the same equipment of a dedicated API plant

The control of the allowable amount of residuals will be carried out through the performance of the cleaning validation. In the facility planning, the best design efforts to remove dead spots in piping, vessels, and ducting are essential.

## Residuals of Additives

These include additives, catalysts, heavy metals, and filtration agents. The process steps to remove these additives are foreseen so that they are removable generally by means of physico-chemical methods, such as filtration and precipitation. These will be included in the impurity profile control if necessary.

## Production Plant Origin Residuals

The examples are exfoliated lining materials from agitators in the reactors, filter fiber debris, mingling of foreign materials resulting from damage to equipment (bolts, pieces of metal), fragments detached from rotating parts of equipment, mingling of harmful sealant liquids, and residuals from construction work.

To control the occurrence of contaminants originating within the production plant, it is necessary to plan equipment with sufficient toughness and reliability (maintenance obviation). Referred to as “maintenance prevention” in Japan this process is based on experience with similar work and detailed equipment structure information from the design stage, and maintain its reliability through adequate maintenance work (preventive maintenance).

## **Protection Control**

### *Establishing the Protection Level*

Protection control will protect drugs from the residuals in

the production process, the foreign materials which mingle and invade from outside of the production process, and cross-contamination.

The analysis of critical steps also is effective for protection control. Through the analysis of critical process steps, the knowledge about the place (process steps) and the magnitude of contamination risks, which will be caused by the residuals, mingling, invasion, and cross-contamination in the process steps can be obtained.

For the residuals, protection control will be carried out according to the method described above. For the external origin contaminants, as well as cross-contamination, the necessary protection level<sup>Note 7</sup> will be established to protect the process steps concerned by considering the significance of each process step and the level of exposure to the external environment, prior to carrying out each protection measure.

Establishing the protection level means building the framework of the protection measures necessary to protect drugs from residuals and foreign materials that will be sufficient to cope with and be appropriate to the contamination risks.

This will be materialized by a combination of enclosing the equipment together with the use of containment, protection by structures, and HVAC as well as changing rules/SOPs.

Thus, not all the required protection measures are necessarily achieved with the process equipment only.

In order to evaluate the probabilities of contamination occurrence and the magnitude of harm caused by the exposure, the characteristics specific to the API production process described below will have to be studied.

## *Key Elements in Deciding the Characteristics of the API Production Process*

- The production know-how and the experience accumulated from work conducted with the investigational production plant:
  - This work provides basic knowledge on the risk of exposure and the necessary level of enclosure for the facility, and also provides a basis for determining the requirements for equivalency of the facility.
- The process steps where the drug effect is generated
- Information on the critical process steps:

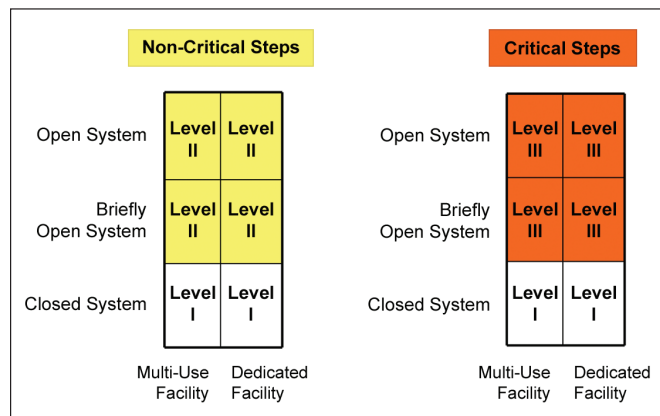

Figure 6. Typical example of a protection level framework.

- The investigational plant provides knowledge on the places where contamination risks with a serious influence on the quality of the API exist, and on the objects that need control.
- The state of the materials handled:
  - The state of the materials handled, such as gas, liquid, wet powder, or powder form (and whether in large or small quantity) will provide knowledge on the risk factors.
- The level of enclosure of the production plant and existing within it will provide knowledge on how, and to what degree, the production plant itself and the equipment within it should be enclosed against the external environment.
- The method of operation:
  - Provides knowledge on the level of exposure to the external environment from the operational standpoint.
- Classification of the production facility:
  - Typical examples are “dedicated” or “common use” plants, and according to the classification of the role of the production facility in terms of which kind of drugs are produced, such as non-proprietary drugs, highly potent drugs, or high sensitizing agents. The necessary countermeasures against cross-contamination are different.

## *External Origin Contaminants*

External origin contaminants include those introduced through mingling and through invasion from outside the production process.

## Raw Material Origin Contaminants

The threat of the mingling of impurities, adhesives, denatured materials, etc. contained in raw materials, and indication of mistakes or management mistakes, such as mislabeling and inaccurate/incomplete directions for use are potential risks. Receiving checks and warehouse management must be carried out so as to prevent foreign materials from being introduced into the production process and the control of the impurity profile, as well as appropriate advice to the contracted factories involved will be important.

## Insect, Animal Origin Contaminants

Every stage, from the factory construction phase to operation, offers chances of invasion. So, many kinds of measures may be adopted as deemed necessary, such as the removal of places where growth/breeding occurs, the blocking of potential routes of entry, and extermination measures using chemicals in accordance with each invasion route (pest control).

Also from the viewpoint of factory planning, the designers must be aware of the impact of many factors, such as the presence of trees around the factory, the location of septic tanks and effluent points, the layout plan of ante-rooms, the sealing of openings of doors and rooms, warehouse management, the planning of carry-in/carry-out areas, and other precautions.

## Human Origin Contaminants

Contaminants may move and mingle with the movement of

people. In order to cope with these issues, establishing an appropriate layout based on the routes for movement and zoning planning (see section on Factory Layout Planning) and establishing appropriate changing rules and enter/exit rules will be effective together with the proper strategy to enclose the production plant. The proper training of operators involved in the production process and the effective management of measures such as sanitary control also will be effective.

## Fine Particles, Gas, Bacteria, Mold, etc. from Business Places External to the Factory

Contaminants may invade from external business places owing to the factory layout and site conditions. Measures may be adopted to decide the direction of air intakes or installing appropriate filters taking into consideration the existence/location of plants producing poisonous/toxic substances around the API production factory and of the waste liquid treatment facilities.

In preventing the growth of mold in the factory, paying attention to humidity control will be of key importance. This relates especially to the prevention of dew condensation on the inside surfaces of walls and windows.

## Contaminants Originating from the Building or its Fittings

Materials or substances originating from the building itself or its fittings, such as paint which has peeled from the steel frame, rust, or items like bolts or nuts, may mingle as foreign materials. It will be important to take countermeasures through maintenance work on the factory, as well as paying attention to these issues at the design phase and the quality control at the construction phase.

The subject of maintenance can be approached in two ways, namely maintenance obviation, which will mainly be a concern during the design phase and preventive maintenance that will be practiced during operation of the facility. Improving the quality of the facility from a maintenance viewpoint by changing materials from carbon steel to stainless-steel to prevent rust is an example of maintenance obviation.

## Airborne Particles, Gas

These contaminants represent the main factors in the cross-contamination threat.

The magnitude of the harm will be different for proprietary and non-proprietary drugs even if the contamination may be the same (same contaminants and same mechanism of occurrence) so that measures which are appropriate to each case will be necessary. For example, the class level of cleanroom will be different according to the drugs handled.

In the consideration of planning of the factory, establishing an appropriate layout, changing rules, and enter/exit rules based on the routes for movement, zoning, and HVAC planning will be necessary.

## Process Water Origin Contaminants

The use of suitable water that fits the requirements of the API being produced is important, as there are various kinds

of process water, such as drinking water, purified water, UF water, and WFI. According to the equipment used for producing the water, adequate measures like bacteria control, pressure control, temperature control, and maintenance, etc. will be required.

## Apparatus for Cleaning

Residuals of foreign materials which are related to cleaning operations like detergents and brushes are potential contaminants. The automation of the factory has a limit in terms of costs and performance so manual cleaning is inevitable. An appropriate SOP will be necessary.

The above measures have been summarized individually so far, as prevention of the introduction of foreign materials, pest control, cleanliness control, sanitation control, factory planning, and facility control. From the protection control viewpoint, prior to carrying out these countermeasures, the location of contamination risks and their magnitude will be evaluated and based on this knowledge, the required protection levels for the API will be set up, followed by establishment of the corresponding hardware/software.

## **Cross-Contamination Control**

The threat of cross-contamination is related to both internal origin contaminants and external origin contaminants. As the mechanisms of this threat become apparent, the following points are raised:

- Cases where contaminations are caused by operators or by air moving between different facilities by way of such common facilities as corridors and elevators.
- Cases where contaminations occur due to residual raw materials, intermediates, and APIs when products are switched.

The concrete measures are different according to the following cases.

- Where protection measures for the API itself will be enough, such as with non-proprietary drugs and additives.
- Where drugs are poisonous or highly potent and protection of personnel and the environment from the API is required.

## *Human/Air Origin Contaminants Carried between Different Facilities and by Means of Common Facilities such as Corridors and Elevators*

In the case of non-proprietary drugs, necessary protection levels will be established based on the knowledge of the locations of contamination risks within the process steps. In the case of poisonous or highly potent drugs, necessary barrier levels will be established for the protection of personnel/the environment. The requirements which apply in these two kinds of cases may conflict with each other so facility specifications must be established through the integration of API protection and protection of personnel/the environment.

For high sensitizing API at present, because the quantitative evaluation method for allowable contamination limits has not yet been established, a containment facility for the API or the use of a dedicated facility may be studied as options.

## *Cross-Contamination at a Common Facility at the Time of Product Switching*

The common facilities in a multi-product plant require cleaning at the time of product switching. This cleaning work will be carried out based on the allowable residual amount inside the plant which is established to maintain the required level of purity for the drugs. In the case of highly potent or poisonous drugs, adding to the control based on the allowable residuals mentioned above, the treatment to make it harmless by deactivation will be necessary.

The containment of the API or the use of a dedicated plant may be studied as options.

## **Factory Layout Planning**

In this paragraph, the application of the contents discussed so far to the factory layout design will be introduced. The outline of the design procedure is shown in Figure 7 and Figure 8 together with an applied example in Figure 9. Layout planning is one of the concrete measures for protection control and it is aimed at external origin contaminants and those introduced by cross-contamination. Thus, it provides only a part of the necessary protection control. However, it raises issues that must be considered at an early stage of the construction project for an API production factory, and has significant importance in deciding the quality of the production environment.

## **Outline of Factory Layout Planning**

To start factory layout planning, the basic production scale and functions will be decided by the company management according to their requirements, such as the factory concept and the allocation of resources.

Factory layout planning will be divided into two levels: the overall layout for the factory area as a whole and the layout for the production factory itself. The overall layout for the factory area will be an input condition for planning the internal layout of the production factory, and they are obviously closely related to each other as can be understood by the matter of the selection of the setting of the production factory within the overall area. In the study of overall factory area layout, material/energy balances, required factory functions, such as production, management, distribution, research and development, zoning, and people/material/energy flows are examined in relation to each other.

The following three requirements will decide the basic specifications although limits on the amount of space available or revision of the functions may occur owing to budget restrictions on the construction cost.

## *Production Process Requirements Decided from the Production Capacity Required*

- Establishment of process flows [material/energy bal-

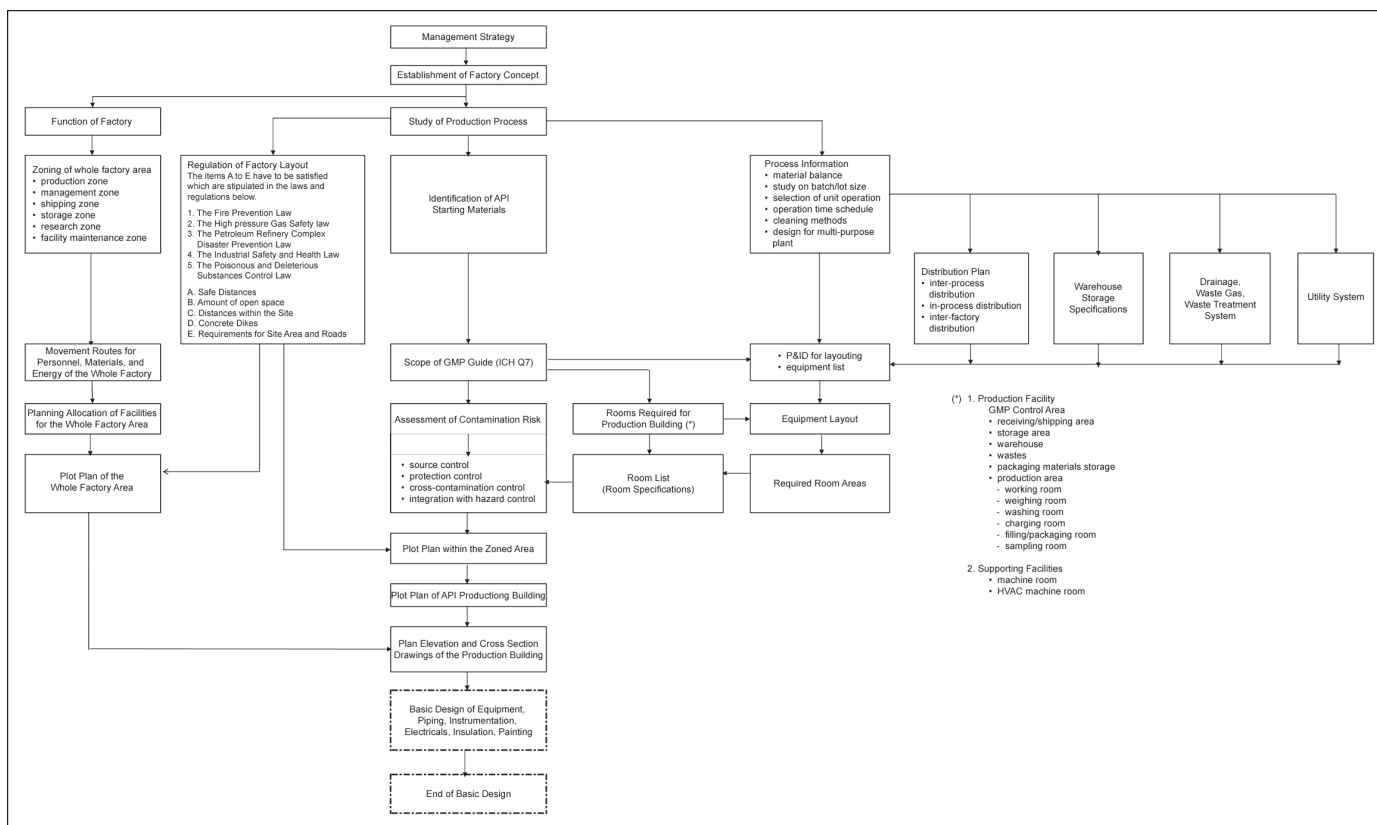

Figure 7. Procedure of factory layout planning.

ances, batch/lot size, selection of unit operation, selection of cleaning methods, establishment of operation time schedule, working out the Piping and Instrument Diagram (P&ID)]

- Material distribution planning
- Specifying of warehouse stock conditions
- Waste water/gas, waste treatment planning
- Planning of utility systems

### Regulatory Requirements

Satisfying the regulatory requirements that apply to the layout is indispensable.

### The Requirements of "GMP Guide for API (ICH Q7)"

- Identification of API starting materials and the scope of GMP management
- Identification of critical process steps and the scope of validation

As the items that need studying mentioned above will influence each other, various professional engineers need to cooperate to work out the layout. Figure 7 shows an outline of these procedures. However, in actual designing, project engineering techniques will be employed effectively as trial-and-error and coordination work between professionals are indispensable.

Figure 7 shows an example where the scope of factory planning is downstream of the scope of ICH Q7. The scope of planning will differ depending upon which stage of development phase (Phase I ~ Phase II ~ Phase III ~ commercial

production), and production phase (raw materials ~ intermediate ~ significant intermediate ~ final intermediate ~ API) are assigned to the scope of the factory.

Also, in the case of planning a multi-purpose factory, which produces multiple APIs or intermediates, different considerations from those for a dedicated plant will be necessary from the viewpoint of cross-contamination prevention.

Risk assessment will be considered to be carried out from an overall scale level to a detailed scale level stepwise, such as from the entire factory to process systems, sub-process systems, unit operations, and sub-systems which constitute unit operations. Figure 8 shows the procedure of risk assessment up to the figuring out of the concept layout planning based on the information regarding process steps and contaminants. The start is made from the identification of the API starting materials and establishing the scope of ICH Q7.

The next step is risk assessment from the viewpoint of source control, protection control, cross-contamination control, and establishing provisional control area classifications by analyzing zoning and finding necessary buffer zones.

During these procedures, critical process steps will be identified, establishing building/HVAC zoning, and movement route analysis will be carried out.

After completing risk assessment based on the given process information, and getting the conclusion that residual risks are within allowable limits, a conceptual layout will be set up together with control area classifications and its specifications.

After that, the design output of the above mentioned pro-

cedure in turn becomes the input conditions of the following risk assessment at the detailed design phase and operation phase making use of assessment techniques appropriate to each phase. Risk will be assessed for the contaminants and mechanisms of contamination identified, carrying out additional hard/soft-ware measures.

It will be a more practical planning tool by incorporating in advance the knowledge acquired by the experience of project execution from detailed design to test operations, and the knowledge of additional preventive measures acquired by the risk analysis, into the specifications of control area classifications.

Various well-known risk assessment methods exist in addition to that proposed in this article. Failure Mode, Effects, and Criticality Analysis (FMECA) may be applicable to the risk assessment of unit operations at the detailed design phase. Also, HACCP, which at present is applied mainly in the food production industry, may be efficiently applied at the operation phase.

## Zoning

Zoning is divided into entire factory area zoning and the production factory zoning.

### Entire Factory Area Zoning

It is the plot plan which lays out all the elements which make up the factory area complex, such as the production area, research and development area, energy center, distribution center, and welfare area. The following are points to which attention should be paid:

- The configuration of the factory site area, the surrounding environment, natural conditions (sunshine, wind direction), the distance from each contaminant source (production area of highly potent substances and/or agricultural chemicals, waste water treatment facilities, etc.), wind direction, and movement routes inside the factory area must be taken into consideration in the site planning.
- Personnel/material movement routes in the site and tie-in points of utilities
- If necessary, expansion/increase must be taken into consideration.

### Production Factory Zoning

Zoning has as its aim the protection of the production plant by ensuring a proper production environment. Thus, prior to zoning, an analysis of the production process is indispensable.

The zoning of a production factory will be established based on provisional area classification, which is the result of risk assessment work based on the process conditions – Figure 9. This work will include such steps as:

- Clarifying process steps (production flow, properties of materials handled, equipment specifications, transport system, etc.)
- Identifying critical process steps and a rough plot plan of necessary rooms

- Finding necessary protection levels (Level I ~ III) and establishing provisional area classifications
- Selecting the HVAC system (re-circulating, all fresh)
- Establishing changing rules

### Zoning Plan of each Class of Area

The plot plan of each area class will be in accordance with the movement route plan for the entire factory complex. The following are points to which attention must be paid:

- Concentrate as much as possible on the areas requiring equal protection levels and the areas requiring equal clean levels. In this way, the prevention of cross-contamination, the clarification of the routes of movement, and the rationalization of HVAC systems can be achieved.
- Concentrate on those areas where hazardous/poisonous materials are handled.
- Separate the areas legally defined as “hazardous” and “non-hazardous” so that the regulations that apply to hazardous areas will not need to be applied to the whole factory area.
- The supporting areas that include washrooms, toilets, rest rooms, and storage for waste materials will be positioned so as not to face directly to the production area in a way that may cause contamination.

## Moving Route Planning

In the planning of routes for movement, the routes for the entire factory area and those inside the production factory itself will naturally influence each other. The basic structure of the layout will be established by studying the combination of the zoning requirements and the routes for movement inside the factory.

In the analysis of personnel/material/air flows, attention will be paid to work procedures, handling volume, and work efficiency in studying the prevention of cross-contamination.

### Entire Factory Area Movement Routes

The following are the points of concern for the analysis of the movement routes in the entire factory area.

- The receiving routes for raw materials and other materials
- The routes followed by transportation and pick-up vehicles
- The product shipping route
- Routes for the movement of wastes
- Routes of movement to be followed by factory personnel and visitors
- Energy flows such as electricity and heat sources

### Personnel/Material/Air Flow Inside the Factory

Based on the zoning, the moving route analysis will be carried out in order to find that moving of materials, humans, and air across the different zones will give no contamination risks to the production environments and the products that cannot be allowed. In case such risks are found, proper counter measures

# Planning an API Production Factory

have to be provided. Such buffer zones or areas such as pass boxes/pass rooms and ante-rooms may be raised as examples. Also, movement analysis may find the necessity for additional areas like corridors owing to the operational necessity.

The following are the points of concern for the study involved in the analysis of movement routes inside the factory:

- The corridors and elevators for personnel and materials will be installed according to necessity, and consistent with each protection level, within each protected area. Whether such areas should be classified as level I or level III is relevant to not only the needs of additional buffer areas,

such as ante-rooms or A/L owing to zone control reasons, but also to the area of the cleanroom or that of the building and the HVAC loadings.

This classification also is relevant to the frequency of changing for operators, which raises issues of operability and cost incompatibility. Thus, case studies on these issues will be important before deciding the building configuration or the number of stories and going into details of the layout.

- The physical dimensions of corridors and loading conditions will be set up according to the purpose of use, such as personnel only, materials only, common for personnel/materials, and equipment installation at maintenance.

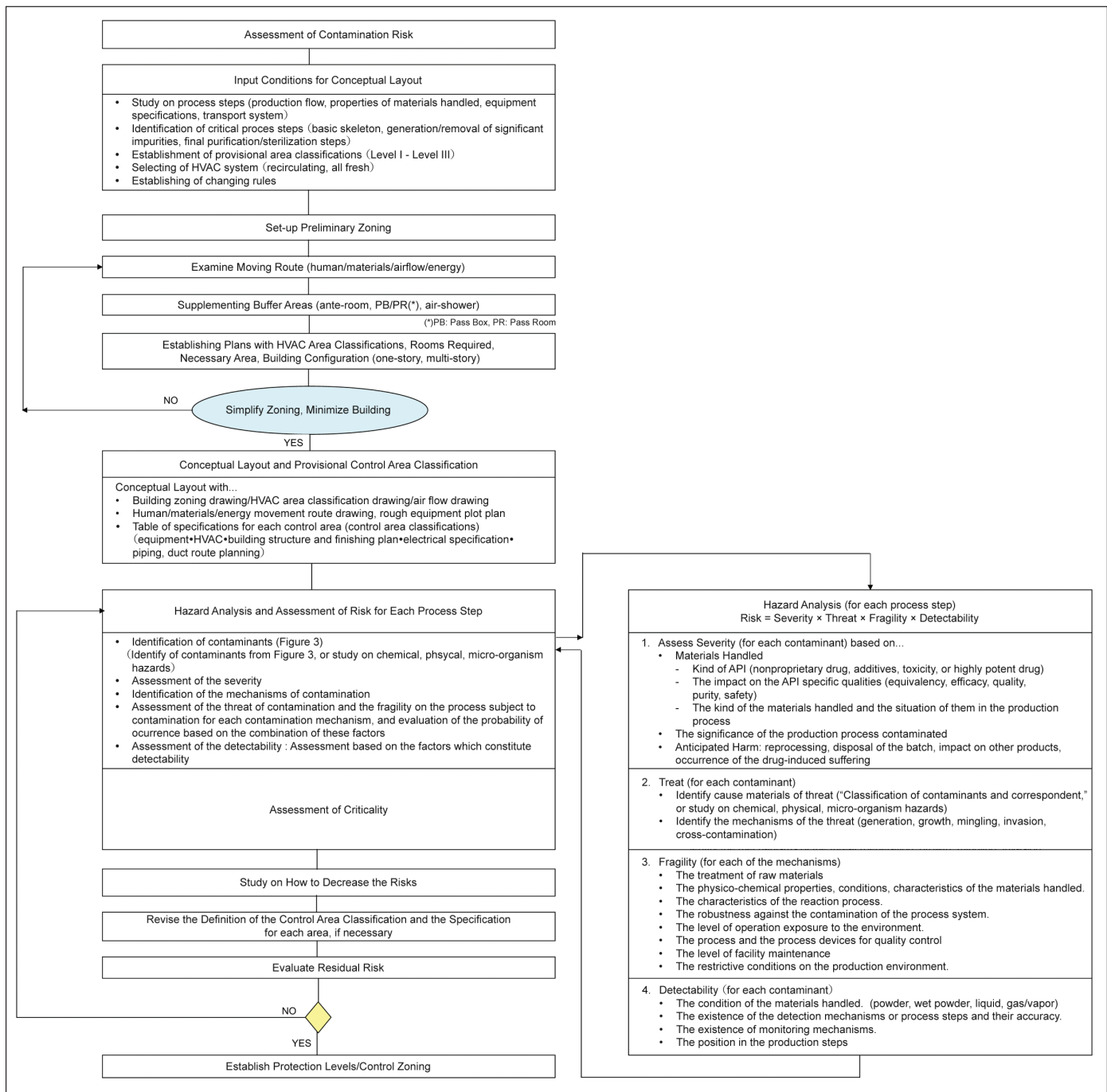

Figure 8. Risk assessment procedure.



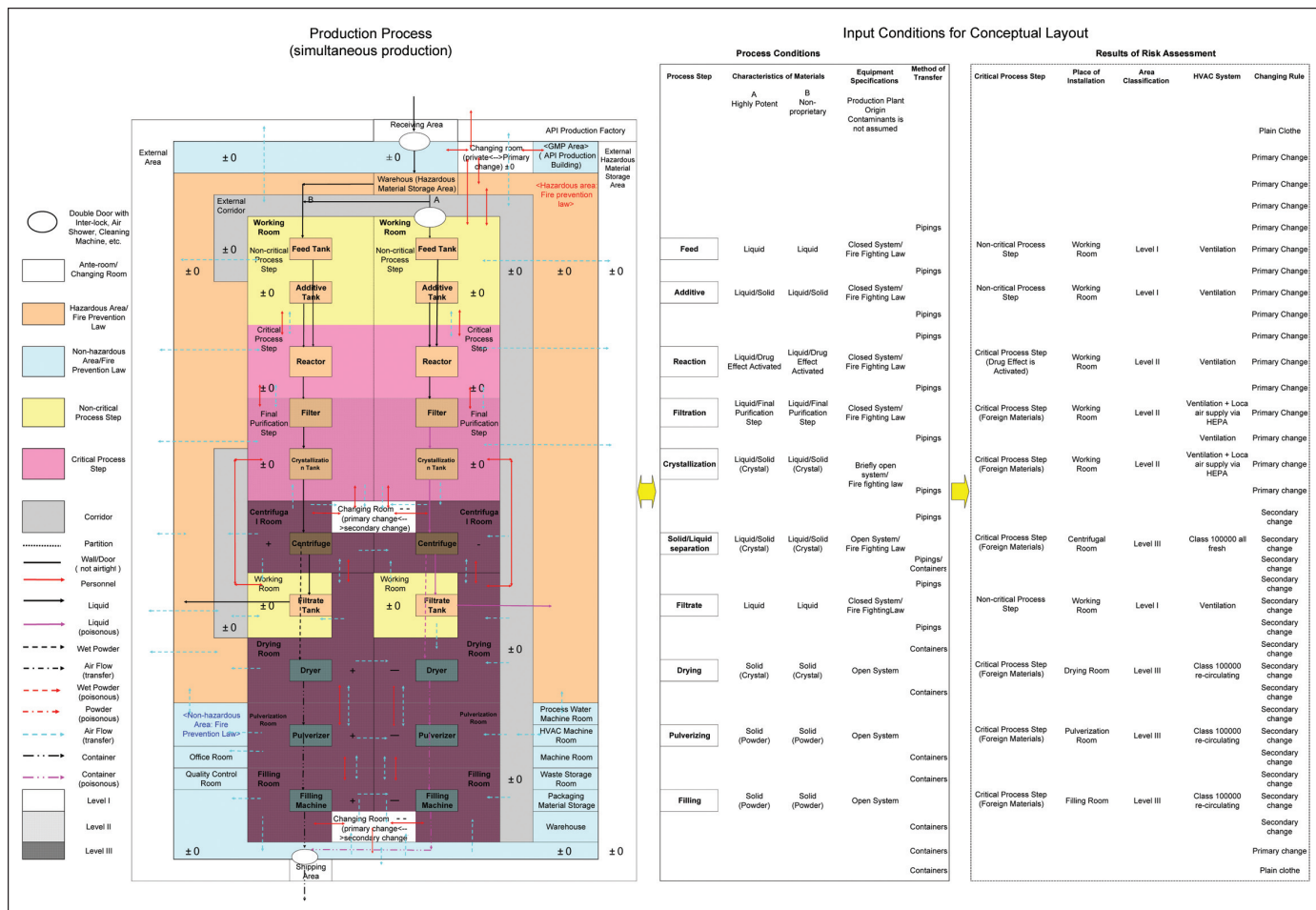

Figure 9. Example of conceptual layout.

- By installing buffer areas such as changing rooms, ante-rooms, air-locks, pass-rooms, and pass-boxes, issues on air-flows will be settled. Also, enforcement of enter/exit control to the protected area will ensure protection from human origin cross-contamination.
- The routes for the movement of personnel and those for materials should be made separate as much as possible and decrease the risk of cross-contamination. In the event that less than ideal routes for movement cannot be avoided, operation procedures like time difference control will be effective to remove the possibilities of contamination.
- Also necessary is the securing of sufficient space and routes for movement that will enable easy checking, repairing, and cleaning.

In Figure 9, a table of input conditions for risk assessment (process conditions) and the result of assessment with control measures is shown.

A sample of a conceptual layout developed through zoning and moving route analysis also is shown.

During the process of these works, the experienced risk factors described in this article are to be examined.

An appropriate framework will be helpful to evaluate the contaminants and manage the risks, and is shown in Figure 5 and summarized in Figure 3.

## Equipment Plot Plan

The equipment plot plan will be planned according to the process flows and work flows so that the operation will be carried out effectively, while also paying attention to stationary operations that make up the regular production activities and non-stationary operations, such as maintenance, cleaning, and emergency measures.

- Equipment will be positioned according to the production steps as far as practicable.
- Sufficient space for maintenance work will be ensured around the equipment as well as planning a layout which satisfies the need for easy workability and safety by clarifying work flows. Routes for movement for emergencies must be taken into consideration, as well.
- Supplementary equipment for production and piping will desirably be installed as much as possible outside of protected areas so as to increase the cleanability.
- If necessary, future extension of the plant will be foreseen.

## Establishing Control Area Classifications

After setting up the basics of the layout through zoning and movement route analysis, a provisional control area classification will be established. Then, specifications for the basic

Control Classification	Definition	Building	HVAC	Changing Rule	Equipment Specification	Reference
0.0	An area equivalent to the external of the factory: External Area	---	Ventilation	Factory Clothes, Glasses, Outdoor Shoes	Equipment is operated under closed system	---
0.5	An area where APIs or intermediates will be exposed to the environment and not be separated by walls: An area where cleaning-up of the outer surface will be carried out, Pass-room to external area	Walls : ALC + Painting Floors: Concrete + Dust-Proof Painting	Ventilation	Factory Clothes, Glasses, Outdoor Shoes	Equipment is operated under closed system	Clean-Up Air
1.0	An area where APIs or intermediates will not be exposed to the area except in emergency	Walls : ALC + Painting Floors: Steel Floor + Painting, Concrete + Dust-Proof Painting	30% ASHRAE Air Pressure: $\pm 0$ Pa	Factory Clothes, Glasses, Indoor Shoes	Equipment is operated under closed system	Insect Proof Device
1.5	An area where protective measures exist to protect APIs exposed to the area (wet powder, liquid)			Factory Clothes, Glasses, Indoor Shoes	Equipment, or part of equipment, is protected with sheets or curtains	---
2.0	Anteroom for control class 3.0: Pass Room of product, anteroom	Walls: Gypsum Board Ceilings: Gypsum Board Floors: Concrete + Dust-Proof Painting	85% ASHRAE Air Pressure: +12.5 Pa	Changing Room	---	Hand Washer, Locker
3.0	An area for which specific environmental conditions are defined, controlled, and monitored to prevent contamination of exposed APIs or intermediates	Walls: Gypsum Board Ceilings: Gypsum Board Floors: Concrete + Dust-Proof Painting	85% ASHRAE Air Pressure: +25.0 Pa Monitoring with Air Conditioning Device Class: 100,000	Over-Gown, Over-Shoes, Glasses, Dust-Proof Mask, Gloves	Open system equipment, Stainless steel is adopted in the part which is exposed to the environment	No difference in grade

Table A. Example of control area classifications.

conditions of the production facility, building facility, HVAC system, and electrical, as well as changing rules will be made. This specifying work is to be carried out at the basic planning phase or at the beginning of the basic design phase. This is to develop the prerequisite conditions for each element involved in the techniques which constitute plant engineering. These techniques will concern the design of equipment, machinery, buildings, HVAC, electricals, etc. The specifications at this stage will decide the major part of the construction cost factors for the facilities. Hereafter, in the project of creating an API production factory, detailed design work will be carried out with the specifications of this stage as input conditions. Table A is an example of area classifications and related specifications which are developed for buildings, HVAC, and facilities.

## Summary

In order to plan the GMP qualified API production factory, identifying contaminants and establishing the countermeasures based on the mechanisms of contamination, and planning production facilities which are effective in preventing contamination from both hardware and software viewpoints are necessary elements.

In order to give shape to the GMP concept in the factory planning, the “Contamination control of API” is important,

and this control requires the identification and grouping of contaminants and the study of protection measures through three contamination management concepts.

Then, integration of these countermeasures in one set of hardware, enabling the building up of hardware which complies with the concept of contamination control, can be achieved.

An appropriate factory layout will play a significant role as an actual countermeasure in decreasing contamination risks for the API.

## Notes

Note 1: These process steps will include those such as the purification steps for raw materials, the process step where the drug effect is activated, process steps where significant impurities are generated or removed, the final purification step, and the final sterilization step.

Note 2: The 5S are the first letters of the Japanese words ‘Seiri,’ ‘Seiton,’ ‘Seiketsu,’ ‘Seisou,’ ‘Shitsuke,’ and they refer to the basic activities necessary to build a good working environment and will be of importance as one of the prerequisite conditions of GMP practice.

Note 3: This refers to the chemical substances, which the

production process is not intended to generate, such as excess raw reaction materials, by-product, decomposed product, denatured materials, and residual intermediates.

Note 4: A critical process step is a step where the API with the scheduled quality and impurity profile cannot be attained in the event that operation mistakes or mingling of foreign materials should occur.

Note 5: Examples of critical process steps:

1. Process step where the basic structure of the chemical compound is established.
2. Process step where significant impurity is generated.
3. Process step where significant impurity is removed.
4. Final purification step.

Note 6: The following are examples of the change factors on the equivalence at the commercialization phase and after approval:

1. The equivalence of the drug quality: impurity profile and physico-chemical properties
2. The equivalence of the facility: the change of the production facility, process step, or unit operation, the scaling-up of the facility with the accompanying changes in heat transfer rate, changes in the methods of material handling, specifications or handling differences from those of the pilot plant on raw materials, utilities and solvent, the change of construction materials, and physical properties of the powders.

Note 7: A typical example of a protection level framework, which makes use of two-dimensional evaluation axes of the level of exposure of process steps to the external environment, and the significance of the process steps - Figure 6.<sup>4</sup>

## References

1. Pharm Stage, Vol.6, No.1, 2006.
2. Tozaki, K., Chap. 3, Iyakuhiin API kojo no GMP ha-do taiou ni. kansuru gaido-bukku, Dai 2 han GMP ha-do kenkyukai, JIHOU-kabu, 2009.
3. Good Manufacturing Practice Guide for Active Pharmaceutical Ingredients (ICH Q7A), 2001.
4. *ISPE Baseline® Pharmaceutical Engineering Guide, Volume 1 - Active Pharmaceutical Ingredients*, International Society for Pharmaceutical Engineering (ISPE), Second Edition, June 2007, www.ispe.org.

## About the Author



**Kazuo Tozaki, PE**, is a Project Manager with JGC Project Service Co., Ltd. (JPS) for pharmaceutical and food production factory construction projects. He has worked for 26 years at JGC Corp. of Japan in that area as well as in chemical plant projects and has spent the last six years with JPS. He holds a BS and a MS from Kyoto University in

sanitary engineering and finished his PhD course in 1976. He is a member of ISPE and PDA. He worked as a member of a national project which studied the countermeasures on GMP hardware aspects in 2002. As an ISPE member, he served on the API COP working group that developed the Japanese translation of the second edition of the API Baseline Guide. As a Project Manager, he has executed more than 10 EPC projects for API production plants as well as food plants in the past 20 years. He also executed a project for an anti-chemical hazard parenteral drug production plant, together with a number of basic design jobs. He is a registered consulting engineer (chemical) and a registered management consultant. He is a registered provisional auditor of ISO22000 of IRCA /JFARB and is a registered Japan Quality Award self assessor. He can be contacted by telephone: +81-45-743-7469 or by email: tozaki.kazuo@jgc.co.jp.

JGC Project Service Co., Ltd., 13-1 Saido 1-chome, Kounan-ku, Yokohama 233-8550, Japan. 

The Global Information Source for Pharmaceutical Science and Manufacturing Professionals

# PHARMACEUTICAL ENGINEERING®

THE OFFICIAL  
MAGAZINE OF  
ISPE

JULY/AUGUST 2009 VOLUME 29, NUMBER 4

**Pure Steam Generation**  
**WFI Production Methods**  
**Amplified Media Circulation**  
**Maintenance and Facilities Outsourcing**  
**Water and Steam Systems**  
**Interview with Sharon Bleach**  
**Vice President, Global Quality, Operations,**  
**AstraZeneca**

Official sponsor of:



ENGINEERING PHARMACEUTICAL INNOVATION



[www.ISPE.org](http://www.ISPE.org)

# Dust Problem?

Go to where dust and fume pollution meet permanent solutions.

[www.pharmadustcollectors.com](http://www.pharmadustcollectors.com)



We make the toughest, best-built industrial dust collectors in the industry!

Visit [www.farrapc.com](http://www.farrapc.com) today.

**FARR**  
Air Pollution Control

Home About Us Products Applications Contact Us

Gold Series®  
Customer Installation Photos  
Case Studies  
Who's Using Farr  
Testimonials  
Industry Articles  
Product Awards

Download Capabilities Brochure

**Gold Series® Camtain®**  
The dust collector designed specifically for pharmaceutical and containment applications.

Processes Involving Pharmaceutical Dust

**Gold Series Camtain on Pharmaceutical Manufacturing Applications**

- The Gold Series (GS) Camtain units can be used in a variety of pharmaceutical dust collection applications including tablet presses, coating, fluid bed drying, spray drying, blending, granulation and general room ventilation.
- The GS Camtain is perfect for high efficiency filtration where recovery of the product is not required.
- Safe-change containment systems are available for both the filter cartridges and discharge system underneath the collector. The cartridge change utilizes the bag-in/bag-out (BIBO) method while the discharge uses continuous liner technology.
- The GS Camtain can also support traditional dust collection for nuisance dusts and fumes that do not require full isolation and containment.

Download Gold Series on Pharmaceutical Brochure

Benefits  
Health Safety Co  
Equipment O  
Proper Ap  
Users a  
Farr



**FARR**  
Air Pollution Control



Farr APC is a proud member of the Camfil Farr Group.  
Visit [www.camfilfarrapc.com](http://www.camfilfarrapc.com) for offices out of North America.

866-530-5474

Jonesboro, AR • email: [filterman@farrapc.com](mailto:filterman@farrapc.com)



We'll give your  
CFO a reason  
to smile.

*Adding value to enhance your bottom line.*

CRB is a global provider of end-to-end solutions for life science and advanced technology companies. Our solutions deliver enhanced value, productivity and return on investment. Whether you are across town or across the pond, CRB's consulting, design and construction expertise will meet your R&D and manufacturing needs, while adding some black to your bottom line.

1.877.4CRBUSA  
[crbusa.com/ROI](http://crbusa.com/ROI)



Consulting

Design

Construction

Commissioning

Qualification

## EDITORIAL STAFF

### Publications

**Editor and Director of Publications**  
Gloria N. Hall  
**Publications Manager**  
Lynda D. Goldbach  
**Technical Writer**  
Rochelle Runas  
**Publications Coordinator**  
Amy Lecceardone

### Sales

**Director of International Sales**  
David J. Hall  
**Sales Coordinator**  
Valerie Adams  
**European Sales Manager**  
Christine Sainvil

## PHARMACEUTICAL ENGINEERING®

(ISSN: 0273-8139) is published bimonthly by ISPE, 3109 W. Dr. Martin Luther King Jr. Blvd., Suite 250, Tampa, Florida 33607, USA. Telephone +1-813-960-2105. Fax +1-813-264-2816. Periodicals postage paid at Tampa, Florida, USA.



### Subscriptions.

An annual subscription to PHARMACEUTICAL ENGINEERING is included in the membership of ISPE. Any reproduction of the contents of this publication in whole or part is strictly forbidden without the written permission of ISPE. Views and conclusions expressed in articles herein are those of the authors and not necessarily those of the editorial staff, officials and Board of Directors of ISPE.

### US Postmaster:

send change of address to Pharmaceutical Engineering, 3109 W. Dr. Martin Luther King Jr. Blvd., Suite 250, Tampa, Florida 33607.

### Canada Postmaster:

send change of address information and blocks of undeliverable copies to PO Box 1051, Fort Erie, ON L2A 6C7. Canada Post Agreement Number 40041350.

©2009 International Society for Pharmaceutical Engineering. Pharmaceutical Engineering and the logo appearing throughout this magazine are registered trademarks.

### ISPE HEADQUARTERS

3109 W. Dr. Martin Luther King Jr. Blvd. Suite 250  
Tampa, Florida 33607 USA  
Tel +1-813-960-2105  
Fax +1-813-264-2816

### ISPE ASIA PACIFIC OFFICE

73 Bukit Timah Road  
#04-01 Rex House  
Singapore 229832  
Tel +65-6496-5502  
Fax +65-6336-6449

### ISPE CHINA OFFICE

Suite 2302, Wise Logic International Center  
No. 66 North Shan Xi Road  
Shanghai 200041, China  
Tel +86-21-5116-0265  
Fax +86-21-5116-0260

### ISPE EUROPEAN OFFICE

Avenue de Tervueren, 300  
1150 Brussels, Belgium  
Tel +32-2-743-4422  
Fax +32-2-743-1550

[www.ISPE.org](http://www.ISPE.org)



ENGINEERING  
PHARMACEUTICAL  
INNOVATION

The Global Information Source for Pharmaceutical Science and Manufacturing Professionals

# PHARMACEUTICAL ENGINEERING®

THE OFFICIAL  
MAGAZINE OF  
ISPE

JULY/AUGUST 2009 VOLUME 29, NUMBER 4

## ISPE Board of Directors

### Officers

**Chair, Charles P. Hoiberg, PhD, Pfizer**  
**Vice Chair, Alan Mac Neice, Elan Corp.**  
**Treasurer, Andre L. Walker, CPIP, Biogen/IdC Manufacturing ApS**  
**Secretary, Arthur D. (Randy) Perez, PhD, Novartis Pharmaceuticals Corp.**

### Directors

**Nuala F. Cainan, PM Group**  
**Bruce S. Davis, Global Consulting (Immediate Past Chair)**  
**Charlotte Enghave, PhD, NNE Pharmaplan**  
**Nigel Frost, Thermal Transfer Ltd.**  
**Joan L. Gore, RPh, Eli Lilly and Co.**  
**Damian J. Greene, Pfizer Inc.**  
**Tomiyasu Hirachi, EEM Japan Co., Ltd.**  
**David E. Petko, PE, Auxilium Pharmaceuticals Inc.**  
**Stephen M. Tyler, Abbott Laboratories**  
**Stephanie A. Wilkins, PE, PharmaConsult US Inc.**  
**Dr. Guy A.S. Wingate, GlaxoSmithKline**

## ISPE Pharmaceutical Engineering Committee and Reviewers

**Chair, Phillip V. Pursifull, Commission Agents, Inc.**  
**Co-Chair, Judith S. Samardelis, Wyeth BioTech**  
Janice T. Abel  
Jan S. Baldauf, *Environmental Resources Management*  
Stephen Bryan, *AstraZeneca*  
Nissan Cohen, *Start-Up Business Development*  
Rajesh V. Dave, *Wyeth*  
Charlotte Enghave, PhD, *NNE Pharmaplan*  
Jeff Hargroves, *ProPharma Group Inc.*  
James B. Hills, *Sanofi-Aventis*  
Barbara J. Lanman, *Roche Diagnostics Operations Inc.*  
Catherine E. Middelberg, *Wyeth Biotech*  
James M. O'Brien, *NAMA Industries Inc.*  
Miguel A. Perez Colon, *Water Management Associates*  
Dr. Johannes Rauschnabel, PhD, *Robert Bosch GmbH*  
Murray A. Sterling, *Precis Engineering Inc.*  
Stephanie A. Wilkins, PE, *PharmaConsult US Inc.*  
Steven J. Wisniewski, *IPS*

## Editorial Reviewers

Rory Budihandjo, *Boehringer Ingelheim*  
Jose A. Caraballo, *Amgen Manufacturing Ltd.*  
John T. Connor, *Telstar Life Sciences*  
Robert Del Ciello, PE, *Northshire Associates*  
Dr. Thomas C. Dine, *Dine Consultancy Ltd.*  
Martin Dübblin, *Y-Tec GmbH*  
Ronald C. Gaughf, *Eli Lilly & Co. (retired)*  
Mervyn L. Hamer, *Intercell USA*  
Orlando Lopez, *Alpharma Integrated Solutions*  
Joseph J. Manfredi, *GMP Systems, Inc.*  
Hank Moes, *Arion Water Inc. (retired)*  
Philippe Robin, *Jacobs France*  
Andrzej J. Szarmanski, *Polpharma SA*  
Takeshi Takashima, *Powrex Corp.*  
Richard S. Tessier, PE, *Novartis Pharmaceuticals Corp.*  
Dr. Slawomir Wielinski, *GlaxoSmithKline Pharma SA*  
Bruce R. Williams, *Williams Process Ltd.*  
Jing Zhou, *Foster Wheeler*

## ISPE Professional Staff

### CORPORATE

**President/Chief Executive Officer, Robert P. Best**  
**Professional Advisors**  
**International Regulatory Affairs Advisor, Douglas I. Ellsworth**  
**European Regulatory Affairs Advisor, John Berridge**  
**Asia-Pacific Regulatory Affairs Advisor, Robert W. Tribe**  
**University Relations Advisor, Jon S. Tomson**  
**Technical Documents Writer/Editor, Gail Evans**  
**Regulatory Web Site Consultant, Eileen Junker**  
**Technical Documents Advisor, Russell Madsen**  
**European Education Advisor, Dr. Kate McCormick**  
**North American Education Advisor, Jeffery N. Odum**  
**Technical Consultant, Sinn Wyn**  
**POLI Technical Project Manager, Chris Potter**

### NORTH AMERICA

#### ADMINISTRATION

**Vice President of Administration/CEO, Victoria Smoke**  
**Administrative Coordinator, Debbie Miller**

#### Accounting

**Director of Accounting, Alicia Aponte**  
**Accounting Manager, Meredith Pritchett**  
**Accounting Coordinators**  
Julie Amburn  
Shirley Noble

#### Event Operations

**Director of Event Operations, Kindra Bess**  
**Event Operations Coordinator, Danielle Shelton**

#### Information Systems

**Director of Information Systems, Chris Muratoro**  
**Application Needs Analyst, Roberto Diaz-Viana**  
**Help Desk Technician, Michael Shelp**

#### Human Resources

**Director of Human Resources, Trudy Contessa**  
**Compensation and Benefits Coordinator, Holly Smith**

#### International Sales

**Director of International Sales, David J. Hall**  
**Sales Coordinator, Valerie Adams**

#### KNOWLEDGE MANAGEMENT

**Continuing Education**  
**Director of Continuing Education, Virginia (Ginger) Phillips**  
**Continuing Education Coordinator, Lisa Steward**

#### Knowledge Management

**Director of Knowledge Management, Carol Winfield**  
**Web Site Technical Specialist, Chris Grab**  
**Web Site Associates**  
Kathleen McKinnon  
Melanie Woods

#### Publications

**Editor and Director of Publications, Gloria N. Hall**  
**Publications Manager, Lynda D. Goldbach**  
**Technical Writer, Rochelle Runas**  
**Publications Coordinator, Amy Lecceardone**

#### Regulatory Affairs

**Regulatory Affairs Specialist, Gina Chan**

#### Technology-Based Learning

**Technology-Based Learning Manager, Rae Hayward**  
**Technology-Based Learning Coordinator, Connie Garcia**

#### Training

**Director of Training, Alicia Montes**  
**Training Program Coordinator, Jessica Bradley**

## MEMBER RELATIONS

**Vice President of Member Relations, Karleen Kos**  
**Affiliate and Chapter Relations**  
**Affiliate and Chapter Relations Coordinator, Tracey Ryan**  
**Business Initiatives**  
**Director of Business Initiatives, Scott Ludlum**  
**Business Initiatives Administrative Assistant, Cicelle Domingo**  
**COP Coordinator, Jacqueline Saldana**  
**Member Services**  
**Director of Member Services, Christian DeSouza**  
**Member Services Manager, Alain Vandamme**  
**Member Services Coordinators**

Xuandai Hoang  
Fred Jimenez  
Diane Lakner  
Maria Mendoza  
**Shipping/Fulfillment Assistant, Mark Bunker**

### Membership Development

**Director of Membership Development, Linda Brady, CAE**  
**Membership Development Coordinator, Angela Brumley**

### Professional Certification

**Director of Professional Certification, Jerry J. Roth**

## MARKETING COMMUNICATIONS

**Director of Marketing Communications, Alison Matherly**  
**Communications Manager, Marni Schribman**  
**Marketing Communications Associate, Heather Fortson**  
**Traffic Coordinator, Lisa Maccaroni**  
**Graphic Designer, Karelina Lopez**

## EUROPE

**Vice President of European Operations, Paul K. Jordan**  
**European Operations Director, Elmarie Herloff-Petersen**

### Member Relations

**European Sales Manager, Christine Sainvil**  
**European Member/Affiliate Relations Manager, Marie-Hélène Charles**  
**European Services Coordinator, Francesca Rollo**

### Events/Conferences

**European Conference Manager, Michela Melis**  
**European Education Program Manager, Eralda Azizaj**  
**European Event Logistics Administrator, Dorothy Henry**  
**European Event Logistics Coordinator, Emma Boyd**  
**European Education Program Coordinator, Laura La Porta**

### Operations

**European Customer Service Coordinator (Membership), Evariste Biyebe**

### Marketing Communications

**European Marketing Manager, Claudia Fortes**  
**European Marketing Coordinator, Hanna Kuikka**  
**European Web Site Coordinator, Vicky Laurijsen**

## ASIA PACIFIC

**Asia Pacific Operations Manager, Chester Chu**  
**Asia Pacific Affiliate Relations Manager, Rhonda Ng**  
**Asia Pacific Customer Service Coordinator, Dex Wah**  
**Asia Pacific Marketing Communications Manager, Sharon Lim**

## CHINA

**China Membership and Affiliate Relations Manager, Cheryl Siow**  
**China Event Manager, Sarah Xiao**  
**China Customer Relations Coordinator, Danni Cao**  
**China Sales Associate, Jackie Liu**

# PARSONS

Integrated Solutions for the Global Life Sciences Industry

Engineering, Architecture, Procurement,  
Program and Construction Management, Validation







The Global Information Source for Pharmaceutical Science and Manufacturing Professionals

# PHARMACEUTICAL ENGINEERING®

THE OFFICIAL  
MAGAZINE OF  
ISPE

JULY/AUGUST 2009 VOLUME 29, NUMBER 4

## Cover Photo

Courtesy of CRB  
Consulting Engineers.

## Cover Design

Lynda Goldbach, ISPE  
Publications Manager

## Current Issue/Theme

JULY/AUGUST 2009  
*Utilities*

## Next Issue/Theme

SEPTEMBER/OCTOBER 2009  
*Management of  
Globalization*  
Publishes 21 September  
2009

## Articles

- 8 Design of Pure Steam Generation and Distribution Systems**  
by Hugh Hodgkinson
- 20 Methods of Producing Water for Injection**  
by Henry Brush and Gary Zoccolante
- 30 Amplified Media Circulation – A New Way for Enhancing Sterilization Cycles**  
by David A. Karle, Gerald McDonnell, and Teppo Nurminen
- 38 Maintenance and Facilities Outsourcing Excellence – An Industry Case Study**  
by Pdraig Liggan
- 44 Industry Interview Series: Sharon Bleach, Vice President, Global Quality, Operations, AstraZeneca**  
by Rochelle Runas

- 48 Rouge in Pharmaceutical Water and Steam Systems**  
by ISPE Critical Utilities D/A/CH COP

## Departments

- 56 Global Regulatory News**
- 60 ISPE Update**  
PQLI Tours Asia  
Global Regulators and ISPE Members Make for Washington Conference Success  
ISPE Launches Three New Online Learning Product Lines  
ISPE Strasbourg Conference to Focus on Managing Knowledge through Science and Risk Assessment  
Event to Showcase Facility of the Year Award Winners from DACH Region  
New ISPE Technical Document and Webinar Offer Pragmatic Solutions to Maintenance Issues  
Sichuan University Student Chapter Takes on Glossary Translation  
New Knowledge Briefs Published
- 64 Classified Advertising**
- 66 Advertiser's Index**

## On-Line Exclusive Articles

### Electro Membrane Technology Boosting Bioreactor Processes

by René Fuhlendorff, Arvid Garde, and Jens-Ulrik Rype

### Working Height Velocity Measurement in Conventional Cleanrooms

by William Mason, Bernard McGarvey, PhD, Thomas R. Spearman, PE

### A Risk Assessment Approach to Planning an API Production Factory

 by Kazuo Tozaki

visit [www.ISPE.org/PharmaceuticalEngineering](http://www.ISPE.org/PharmaceuticalEngineering)



# A Single Resource...



Site  
Integration



Infrastructure  
Integration



Product  
Integration



Process  
Integration

for TOTAL Cleanroom Confidence.

**Planning & executing the right cleanroom solution  
for your critical process.**

AES is your single resource to deliver fast track solutions for Pharma & BIO applications, such as:

- API Clean Containment
- Low cost ISO 8/CNC Macro Environments
- Fill/Finish Processes
- Cell Manufacturing Facilities
- Blow/Fill/Seal Facilities
- EU/Grade A Laminar Flow Upgrades

With the AES Pharma Wall System, combined with our expert knowledge of HVAC and process integration, let us show you how the AES "single resource" team can deliver maximum value to your cleanroom investment.

Call Grant Merrill at 888-237-2532 (ext. 139) to arrange your free consultation today.



**aes**

Clean Technology, Inc.

**1-888-AES-CLEAN ext. 139**  
237-2532

[aesclean.com](http://aesclean.com)

This article presents an overview of design requirements of pharmaceutical pure steam generation and distribution systems with particular emphasis on recommended terminology (clean vs. pure steam) and feed water quality requirements.

## Design of Pure Steam Generation and Distribution Systems

by Hugh Hodkinson

### What is Pure Steam?

**P**ure steam is a clean utility used in the pharmaceutical industry with two primary uses:

- sterilization of product contacting components
- humidification of cleanroom and isolator air supplies

Since the above two categories are both critical to the production of pharmaceutical products, the design of pure steam generation and distribution systems is a very detailed process, which must include a wide range of considerations to ensure the steam generated is suitable for product contact and that the distribution system maintains this quality.

Pure steam has traditionally been defined as having Water For Injection (WFI) quality condensate. While this is still the case for the European Pharmacopoeia (EP), the United States Pharmacopoeia (USP) has more recently defined pure steam specifically. However, this definition of pure steam lists the quality requirements of its condensate, which actually ties in with USP WFI requirements. Furthermore, if the pure steam is to be supplied to sterilizers downstream, it should meet the quality requirements defined in European Norm (EN) 285 and Health Technical Memorandum (HTM) 2010.<sup>1, 2</sup> (Note: these are European and UK standards, but are generally used internationally.) These requirements are summarized in Table A.

The characteristics in Table A are listed because it is important that steam sterilization

takes place with saturated steam. The most effective method of heat transfer from steam is due to condensation. Therefore, the lower the dryness level, the less steam is available to condense. On the other hand, superheated steam will have to cool sufficiently prior to it condensing and non-condensable gases will never condense. All three of these are factors which reduce the efficiency of the heat transfer process.

Note that while, as stated above, pure steam is most commonly used for air humidification in pharmaceutical facilities, the ISPE Baseline<sup>®</sup> Pharmaceutical Engineering Guide on Water and Steam Systems<sup>3</sup> states “Pure steam is commonly utilized in the industry for humidification of “cleanroom” process areas due to possible exposure to the drug product. However, production areas where exposure to the drug product is of less concern commonly utilize chemical free steam for humidification.”

### Pure Steam vs. Clean Steam

There is a lot of debate throughout the industry as to which term is more appropriate: “clean steam” or “pure steam.” In many circles, both terms are acceptable and are often used interchangeably. However, it is the strong recommendation of this author to use the term pure steam for the following reasons:

- Some parties (especially equipment suppliers) use the term “pure steam” to refer to a unit that produces steam, which is suitable for pharmaceutical product contact applications (e.g., for Sterilize In Place processes), but use the term “clean steam” to refer to units which produce steam that is suitable for use in hospitals and similar environments.

This situation became problematic when a contractor ordered a Clean

*Continued on page 10.*

Table A. EN 285 and HTM 2010 Steam Quality Requirements.

Characteristic	Requirement
Dryness	0.9 (0.95 for metal loads)
Superheat	< 25°C
Non Condensables	< 3.5%

High performance teams make the difference.



# Commissioning Agents, Inc.

Our teams are recognized industry leaders in developing better methods to meet your business and regulatory demands. When schedule is your problem, we are your solution.

## Major services include:

- Commissioning planning, equipment start-up, troubleshooting, field execution, verification and qualification (IQ, OQ, PQ)
- Quality Risk Management (QRM) Implementation and Risk Based Qualification Programs
- Validation – Process, Cleaning, Sterilization, Computer
- Process Improvement Services: Process Analytical Technology (PAT), technology transfer, process improvement studies
- Technical services including design reviews, SOP development, and training
- Maintenance program development and implementation
- cGMP Compliance Services – audits, regulatory reviews, improvement projects, submission assistance, and comparability protocols

**Achieve world class manufacturing.**

Call Robert E. Chew, P.E., President  
Robert.Chew@CAgents.com  
+1.317.710.1530

CommissioningAgents.com



*An Employee-Owned Company*

Steam Generator for a pharmaceutical facility, which was actually not suitable for pharmaceutical steam production and it had to subsequently be replaced.

- The ASME Bioprocessing Equipment (BPE) 2007 Guide<sup>4</sup> defines clean steam as “steam free from boiler additives that may be purified, filtered, or separated. Usually used for incidental heating in pharmaceutical applications.” The same guideline defines pure steam as “steam that is produced by a steam generator, which when condensed, meets requirements for Water For Injection (WFI).”
- Many equipment suppliers use the term “pure steam” or “pyrogen-free pure steam” exclusively throughout their documentation. If a pharmaceutical facility refers to “clean steam” throughout all of their documentation and drawings, but “pure steam” is referred to throughout all of the generation skid documentation and drawings, it creates an undesirable disparity.
- The quality of the feed water is in no way related to whether the steam produced is called “clean steam” or “pure steam” so the name used should never be based on the feed water quality.
- Although there are variations throughout the relevant guidance documents, it is common for pure steam to be defined as higher quality than clean steam or at least the same quality. Using the term “pure steam” is unlikely to cause any confusion, but the term “clean steam” is a lot more ambiguous due to different definitions throughout the industry.

## Feed Water Quality for Pure Steam Generators

This is another controversial item in the pharmaceutical industry. There is widespread debate over the quality of the feed water required by a Pure Steam Generator (PSG). The most common feed water used by PSGs is USP and EP Purified Water. The reason that purified water is normally used is because it is available in and distributed through most pharmaceutical facilities. In fact, purified water is a much higher quality than is typically required by a PSG; therefore, it is a needlessly expensive water supply if there is a lower quality supply available which still meets the PSG feed water requirements. There also are parties who advocate using Water For Injection (WFI) to feed a PSG. However, this does not make sense since the most common method of producing WFI is from a WFI Still, which operates on the same principles as a PSG. Therefore, the WFI produced is condensed steam so the feed would have been distilled twice. It should be noted that USP states that the feed water supplied to the PSG must be in accordance with feed water required for a WFI Still or Purified Water Skid. According to USP, for a WFI Still: “The minimum quality of source or feed water for the generation of Water for Injection is Drinking Water as defined by the US EPA, EU, Japan, or the WHO.” However, in practice, many PSGs require a higher standard of feed water than that.

The recommendation of this author is to contact the supplier (or potential suppliers) of the PSG to confirm the acceptable feed water quality. Then a decision must be made

Characteristic	Requirement
pH @ 2 °C	6.5 - 8.5
Conductivity @ 20°C	< 10 µS/cm
Dissolved Solids	< 5 mg/L
Chlorides	< 50 ppb
Free Chlorine	< 50 ppb
Ammonia	< 50 ppb
Total hardness	< 2 ppm
Silica as SiO <sub>2</sub>	< 1 ppm
Endotoxins	< 250 EU/ml

Table B. Recommended feed-water quality for pure steam generators.

as to which water supply in the facility would give the most cost effective feed water. To take a hypothetical example: If there was a de-ionized water loop, a Purified Water loop, and a WFI loop, where all three met the minimum feed water quality requirements, the de-ionized loop would generally be the most economic to extend to supply the PSG. Additionally, producing one liter of de-ionized water as feed is substantially less expensive than producing one liter of WFI. However, it must be stressed that before this decision can be made, the water quality must be confirmed as acceptable for the PSG.

The water quality characteristics listed in Table B can be used as a guideline for the quality of water typically required for supply to a PSG. This has been collated based on feedback from several leading PSG suppliers to the pharmaceutical industry. Note that this is purely a guideline and that the final decision for feed water quality must be made in accordance with the recommendations of the PSG supplier.

### Notes:

1. Pure steam generators will typically give a 3 to 4 log reduction in Endotoxin Level (which will be stated in the upcoming revision to ISPE Baseline® Guide: Water and Steam Systems<sup>3</sup>) which is why this is a requirement for feed water quality. One manufacturer confirmed that they achieve a minimum 3 log reduction in endotoxin levels through their PSGs.
2. Non-condensable levels in the feed water will ideally be less than 3.5% v/v, but if this requirement is not met, the PSG can be fitted with a degasser.

## Specification of a Pure Steam Generator

The key activities of a Pure Steam Generator are to evaporate the feed water, remove non-condensable gases from the system, and remove entrained droplets from the steam, while keeping the steam saturated. Removal of non-condensable gases is necessary because there is a non-condensables limit specified in HTM 2010. Removal of entrained droplets is necessary because dryness is another key quality criterion, but also because these droplets will carry over contamination from the feed water. Saturation is important for effective steam sterilization because most of the energy transferred is from latent heat of condensation.

*Continued on page 12.*



# ELETTACQUA

*pure water technologies*

SINCE 1966

## PHARMACEUTICAL WATER SYSTEMS



MULTIPLE EFFECTS DISTILLATION UNIT

DESIGN AND CONSTRUCTION OF PURIFIED WATER PACKAGES ◊ DOUBLE PASS REVERSE OSMOSIS ◊ R.O. + ELECTRODEIONIZATION HOT WATER SANITIZABLE ◊ ULTRAFILTRATION ◊ MULTIPLE - EFFECT DISTILLATION UNITS ◊ PURE STEAM GENERATORS ◊ STORAGE AND DISTRIBUTION LOOP ◊ COMPLETE TURN KEY PROJECTS ◊ VALIDATIONS IQ, OQ

[www.elettracqua.com](http://www.elettracqua.com)



Common methods of reducing entrained droplets include using demister plates in the main evaporator, designing the evaporator column to be long and wide enough that the steam upflow is low enough that droplets fall back into the boiling feed water, and/or using a cyclone effect so that centrifugal force drives entrained droplets against the evaporator wall (baffles can be used to augment this process).

It is good practice to degas the pure steam produced. If there is a feed water tank on the skid, it is common to heat the feed water and recirculate it so that it sprays back into the feed water tank, enabling non-condensable gases to be released through a stack vent on the tank. If there is no feed water tank, some suppliers can feed a degassing vent directly to the evaporator column. These can operate by means of a falling film on the infeed line to the PSG, where the hot feed water releases non-condensable gases which rise up through a degassing vent. The advantage of fitting this directly to the evaporator is a smaller overall footprint for the PSG, but the vent stack is generally more difficult to remove than from the feed water tank.

Prior to ordering a PSG, it is wise to meet with one or more leading PSG suppliers to discuss the details and exact requirements of your application. Some key items that should be considered for the PSG specification are summarized below. Note that the below list is aimed at design items which are specific to PSGs and is not intended to be an all encompassing list covering items common to specifying any piece of sanitary equipment, such as documentation requirements, testing requirements, safety requirements, construction requirements, etc. Key items to consider when specifying a PSG are:

- The quality of the feed water proposed for the PSG.
- Ensure the PSG outlet is fitted with EN 285/HTM 2010 test points, as well as a test point for taking pure steam condensate samples. If the pure steam does not meet these quality requirements at the facility user points, the first check that should be performed is that the PSG is producing sufficiently high quality steam.
- Ensure the PSG is fitted with a degasser. This gives confidence that non-condensable requirements will be met in the system.
- State the feed water minimum supply pressure. PSGs require a feed water tank and booster pump if the feed water pressure is not a sufficient quantity greater than the pure steam generation pressure – commonly 1 bar (14.5 psi), but this varies between suppliers.
- It is recommended that inlet feed water is used to condense pure steam for inline conductivity monitoring and offline analysis. Otherwise, a separate cooling water supply is required to the PSG skid.
- Effluent from the PSG is going to be hot, and if it is not cooled, a plume of steam will be generated at the waste connection from the skid. So it is recommended to include a blow down vessel in the skid where the effluent is cooled by process water or similar. Also note that the vent from this blow down vessel will typically be exhausting hot water vapor so it is normal to pipe this vent outside the building.
- The flowrate and pressure required at the PSG outlet (based on the requirements of the distribution system users).
- Passivated 316L stainless steel is the recommended material of construction as pure steam is a very corrosive substance. Non-metallic piping materials of PVDF and PTFE could be used if rated for the pressure and temperature. Schedule 80 would be preferable.
- A surface finish of  $Ra < 0.5 \mu\text{m}$  (20 microinch) is recommended for pure steam contacting parts.
- Hygienic connections to be used throughout. High pressure clamps which require a tool to remove are recommended over clamps which can be removed merely by hand.
- Any interaction with the upstream feed water distribution system should be specified, such as feed water request signals sent from the PSG control system and feed water available signals returned to the PSG control system.
- A small stream should be taken off the pure steam outlet, condensed and monitored continuously for conductivity. Note that the ISPE Baseline® Guide<sup>3</sup> states that temperature compensated conductivity sensors cannot be used for critical quality assurance testing of purified water, highly purified water, WFI, and pure steam condensate.
- It is common to record the PSG pure steam condensate conductivity and temperature for a facility's batch records. Since most PSGs are Programmable Logic Controller (PLC) based and do not have permanent data storage, it is recommended that this data is stored either by connecting the PLC to a Supervisory Control and Data Acquisition (SCADA) system or alternatively that the conductivity and temperature signals are routed in parallel to a data logging system. In the case of the latter, it is recommended that a signal is also sent from the PSG PLC to confirm that good quality steam is being produced. Otherwise, it will not be clear from the data logged when the PSG is running properly and when it is in alarm or shut down.
- One item that must be considered when designing a pure steam system is whether and how the feed water system is sanitized. If the feed water is normally cold, but is sanitized by heating the feed water distribution, this can generally be catered for in the PSG design if the vendor is informed up front. However, if a different method of feed water sanitization is used (e.g., chemical sanitization), then it could be necessary to stop feeding the PSG for the duration of sanitization. If there is no feed to the PSG for a sufficient period, it will have to shut down. This would obviously have a drastic effect if the facility air handling units depend on the PSG for pure steam. Note that feed water sanitization depends on the design of the feed water system and is not a requirement of the PSG.
- It is typical for the pure steam distribution system header to be a purely mechanical system. That is, the distribution does not have its own control system. The key parameter that must be controlled in the distribution header is the pressure, which is set in the PSG control system.
- The most common temperature used for sterilization processes is 121°C. 134°C is used for some processes, but this is much less common. These temperatures correspond to steam supply pressures of ~1.1 barg (16.0 psig) and ~2.0 barg (29.0 psig)

*Continued on page 14.*



# In safe hands

Containment Solutions for the Pharmaceutical & Biotech Industries

- Barrier Isolation Systems
- Downflow Containment Booths
- High Containment Screens
- Pack Off and Process Equipment
- Kilo Labs & Glassware Enclosures



For further information please contact us on

North America

502 968 2065

Rest of the World

+44 (0) 1204 571131

[info@howorthgroup.com](mailto:info@howorthgroup.com)

[www.howorthgroup.com](http://www.howorthgroup.com)



respectively. To allow for pressure losses in the distribution system and to buffer the distribution system, it is common to run distribution headers at pressures in the range of 2.5 – 3.0 barg (36.3 psig – 43.5 psig). However, it is important to check the pressure required by each of the downstream users before deciding on the pressure required in the header and corresponding pressure setpoint at the PSG outlet.

## Design of a Pure Steam Distribution System

The design of a pure steam distribution system is more complex than might first appear. The following design guidelines assume that the pure steam generator has been correctly specified and will produce pure steam of a quality that meets USP and EN 285 requirements (as well as meeting EP WFI quality limits for Pure Steam condensate).

Once the PSG has been correctly specified, designed, and installed, it is critical that the distribution system delivers pure steam of a sufficient quality to the facility user points. A poorly designed distribution system can reduce the quality of the steam so that it does not meet the regulations pertaining to pure steam.

### Header Design

Headers must be designed so that they minimize condensate formation and any condensate which is formed is routed out of the distribution system, maintaining a dry steam supply to each user point. To this end, the following design features are recommended:

- Piping runs slope to at least 1%
- Steam traps are recommended:
  - at the end of each header or branch
  - every 30m (~100 ft) on any straight run
  - at each user point or sample cooler
  - where the line transitions from horizontal to vertical (at the bottom of the vertical riser)
  - at thermal expansion loops
  - anywhere condensate could build up and would not otherwise be removed (i.e., there should be no dead legs where condensate can build up)
- Thermostatic steam traps to be used throughout. These are the most common sanitary traps for pure steam distribution systems and have the ability to remove air from the system. Float traps and thermodynamic traps are not free draining and do not release air from the system so they are not recommended.
- Never group steam traps. This means that multiple users are not run to a single trap (this often leads to preferential draining for one piece of equipment, because different pieces of equipment will release condensate at different temperatures and pressures). It also means that the discharge lines from traps must not be connected. Each of these should go to drain through a separate air gap since linking these lines can hinder the release of condensate through one or more of the traps.
- Trap legs for the collection of condensate from the steam distribution system should be of equal size to the distribu-

tion line for sizes up to 4 inch (100 mm) and one or two sizes smaller for lines of 6 inch (150 mm) or larger.

- 30 cm (~1 ft) of uninsulated piping above each steam trap. Thermostatic traps release condensate which is a few degrees colder than the steam saturation temperature would be at the operating pressure. Therefore, the condensate must be allowed to cool so that it is released through the trap.
- Full bore ball valves used throughout, but diaphragm valves are advisable at the sterile boundary of an aseptic system, e.g., the last valve on a line for SIP of a vessel would be a diaphragm valve, but the preceding valves would be ball valves. Diaphragm valves used in a pure steam system require far more maintenance than ball valves.
- Sanitary pressure regulators are to be used where required. Sanitary pressure regulators typically have a bottom mounted inlet and side mounted outlet so that any condensate built up in the regulator flows back through the regulator inlet.
- No direct connections to unhygienic systems. Air gaps to be used at all drain points.
- Hygienic connections used throughout. High pressure clamps which require a tool to remove are recommended over clamps which can be removed merely by hand.
- Passivated 316L is the recommended material of construction as pure steam is low in ions and is a very corrosive substance.
- User point take offs are piped off the top of headers to minimize entrained condensate.
- Headers and take offs are typically sized to give a steam velocity in the range of 20 to 30 m/s (~65 to 100 ft/s) to minimize entrained condensate in the pure steam flows. Note lower velocities also are acceptable.
- Sample points to be easily accessible.
- It is often stated that pure steam distribution systems are self sterilizing and the benefits of polished tubing is questioned. However, it is very common throughout the industry (and recommended by this author) to polish distribution systems to finishes of  $R_a < 0.5 \mu\text{m}$  (20 microinch) or less (depending on the site standard) and is recommended. Sometimes for smaller components such as steam traps, this requirement cannot be met and can be relaxed to  $R_a < 0.8 \mu\text{m}$  (32 microinch).
- Air breaks to be at least twice the size of the relevant pipe diameter.
- Eccentric reducers used for any horizontal reductions in pipe diameter.

A typical autoclave user point is shown in Figure 1. Note that this includes HTM 2010 test points and a pressure gauge as well as local condensate sampling. Not all of these features are required at every user point, as described in the sampling section below. Also note that 50 mm (2") air breaks are used in this example. This is a common length, but air breaks should always be at least twice the pipe diameter used in the given application.

### Sampling

It is recommended to take samples to prove compliance with the following:

*Continued on page 16.*

# Intelligen Suite

The Market-Leading Engineering Suite for Modeling, Evaluation, Scheduling, and Debottlenecking of Single & Multi-Product Facilities

## SuperPro

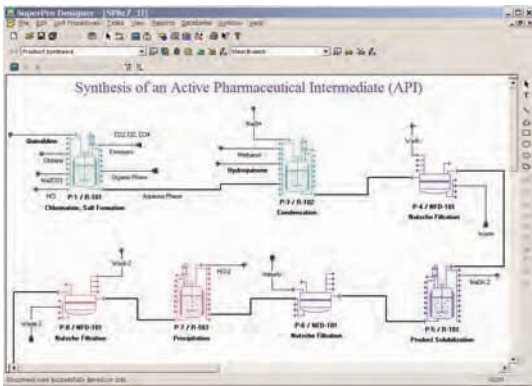

## SchedulePro

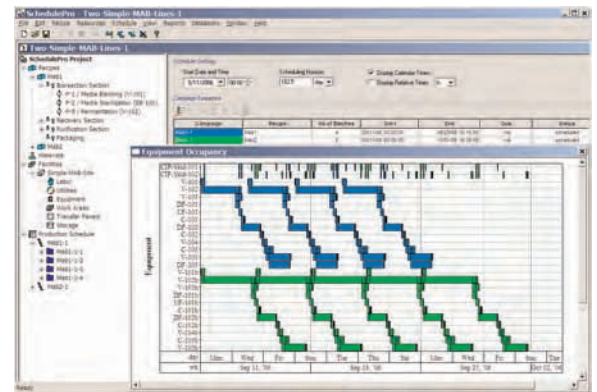

Use SuperPro Designer to model, evaluate, and debottleneck batch and continuous processes

Switch to SchedulePro to schedule, model, and debottleneck multi-product facilities



Tracking of equipment occupancy in multi-product facilities

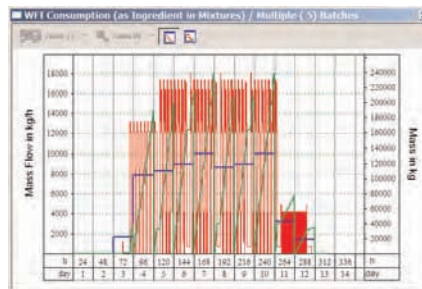

Tracking demand for resources (e.g., labor, materials, utilities, etc.)

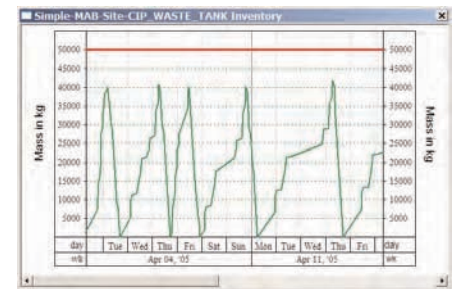

Inventory tracking for raw materials, intermediates, products, and wastes

**SuperPro Designer** is a comprehensive process simulator that facilitates modeling, cost analysis, debottlenecking, cycle time reduction, and environmental impact assessment of biochemical, specialty chemical, pharmaceutical (bulk & fine), food, consumer product, mineral processing, water purification, wastewater treatment, and related processes. Its development was initiated at the Massachusetts Institute of Technology (MIT). SuperPro is already in use at more than 400 companies and 500 universities around the world (including 18 of the top 20 pharmaceutical companies and 9 of the top 10 biopharmaceutical companies).

**SchedulePro** is a versatile finite capacity scheduling tool that generates feasible production schedules for multi-product facilities that do not violate constraints related to the limited availability of facilities, equipment, resources and work areas. It can be used in conjunction with SuperPro (by importing its recipes) or independently (by creating recipes directly in SchedulePro). Any industry that manufactures multiple products by sharing production lines and resources can benefit from the use of SchedulePro. Engineering companies use it as a modeling tool to size utilities for batch plants, identify equipment requirements, reduce cycle times, and debottleneck facilities.

**Visit our website to download detailed product literature and functional evaluation versions of our tools**

**INTELLIGEN, INC. • 2326 Morse Avenue • Scotch Plains, NJ 07076 • USA**

**Tel: (908) 654-0088 • Fax: (908) 654-3866**

**Email: [info@intelligen.com](mailto:info@intelligen.com) • Website: [www.intelligen.com](http://www.intelligen.com)**

**Intelligen also has offices in Europe and representatives in countries around the world**

# Pure Steam Generation

- a. Pure steam condensate complies with USP and/or EP (as relevant)
- b. Pure steam quality complies with HTM 2010/EN 285 dryness, superheat, and non-condensable requirements as described in the introduction to this article

With respect to a. above: Sample coolers are recommended at the following locations:

- At the end of each header
- At each critical user take off, i.e., where pure steam is used on product contacting surfaces such as for equipment SIP or for autoclaves. However, for non-product contacting users such as steam used for humidification,

it is generally acceptable to sample at the end of the relevant header.

It is advisable to fit a hygienic needle valve immediately upstream of the sample cooler so as to control the sample flowrate. It also is recommended to normally fit a steam trap at the outlet of the sample cooler so that it is continuously self sterilizing, but to have a spool piece which can be used to replace the steam trap during sampling (obviously after the system has been isolated and allowed to depressurize and cool sufficiently).

With respect to b. above: HTM 2010/EN 285 test points are recommended at the following locations, at a minimum:

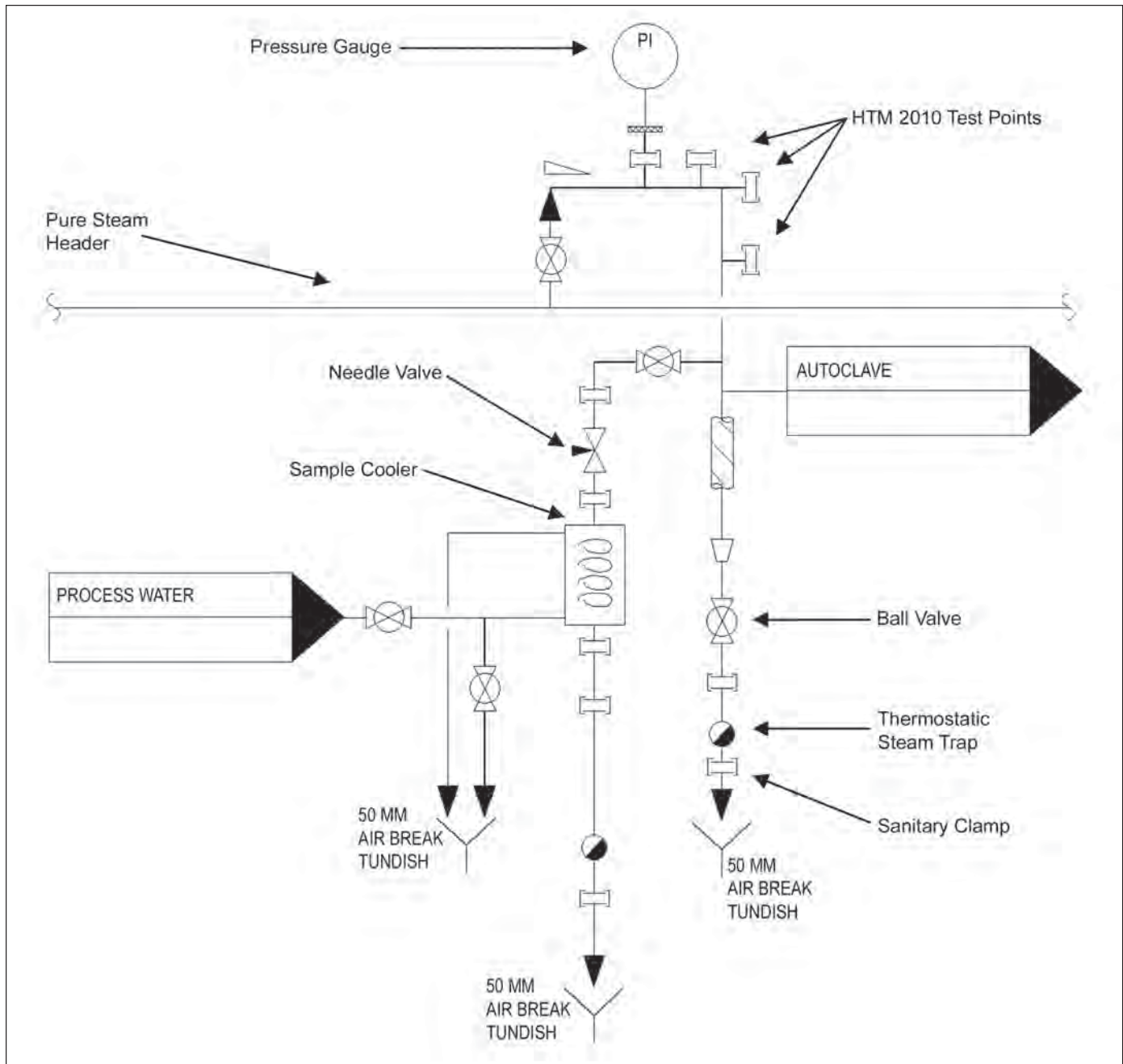
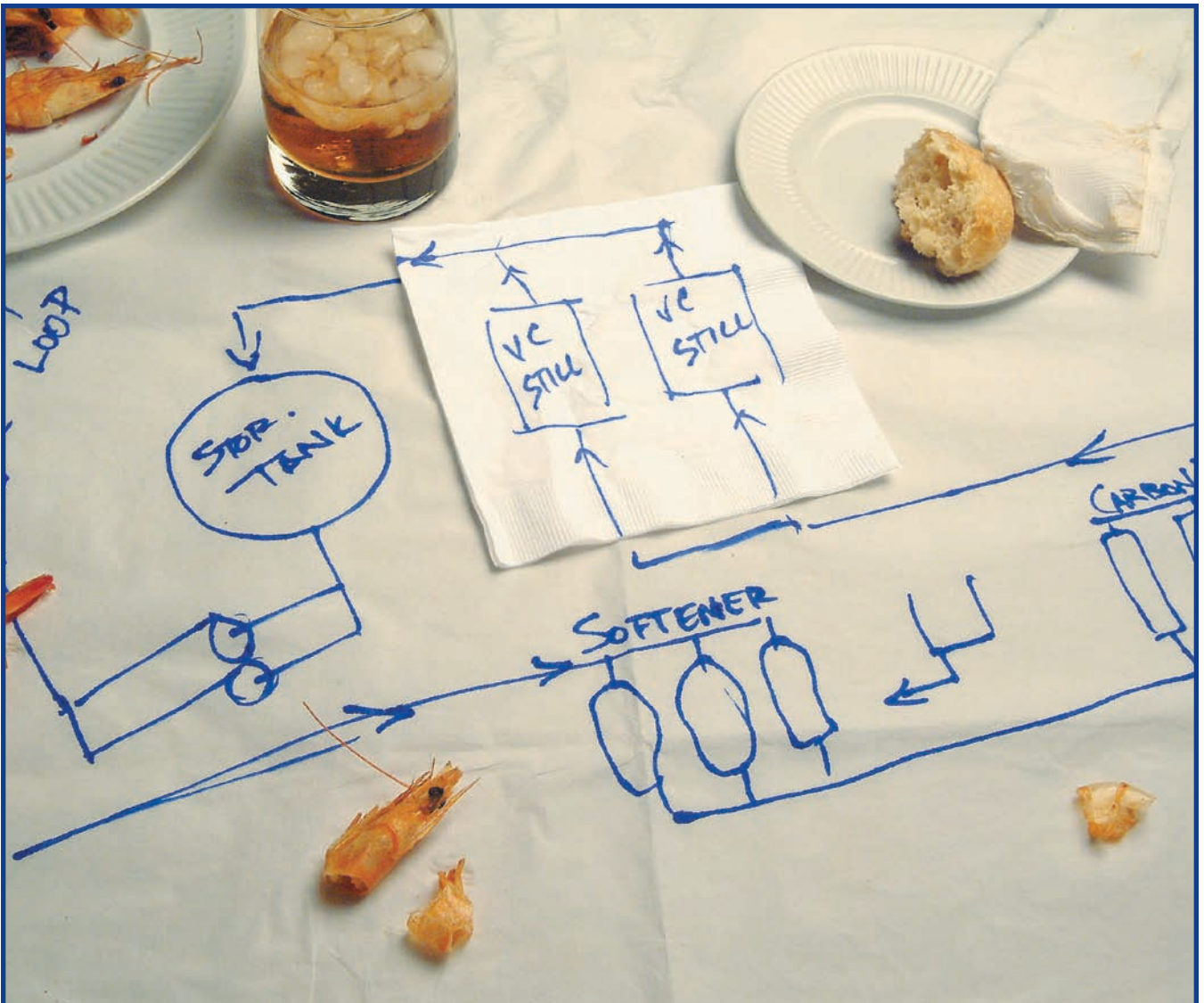

Figure 1. Typical pure steam supply configuration for an autoclave.

*Concludes on page 18.*



**VAPOR COMPRESSION IS JUST THE BEGINNING OF WHAT WE DO.**

**Innovative Solutions For Purified And WFI-Grade Water And Pure Steam.**

It was a big idea that simply got bigger. Today, MECO has grown to provide expert guidance and customized solutions for every phase of water and Pure Steam generation. Whether you need a particular product, a specialized service or an entire water plant designed and built from scratch, MECO delivers. To see for yourself, visit [mecobiopharm.com](http://mecobiopharm.com) or call 1-800-421-1798.

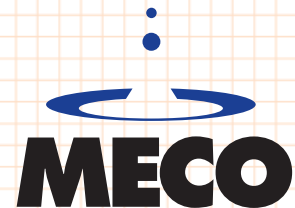

PEOPLE

PRODUCTS

SERVICE

US \_ UK \_ Singapore \_ UAE \_ 800-421-1798 \_ [mecobiopharm.com](http://mecobiopharm.com)  
 12505 Reed Road, Suite 100, Sugar Land, TX 77478

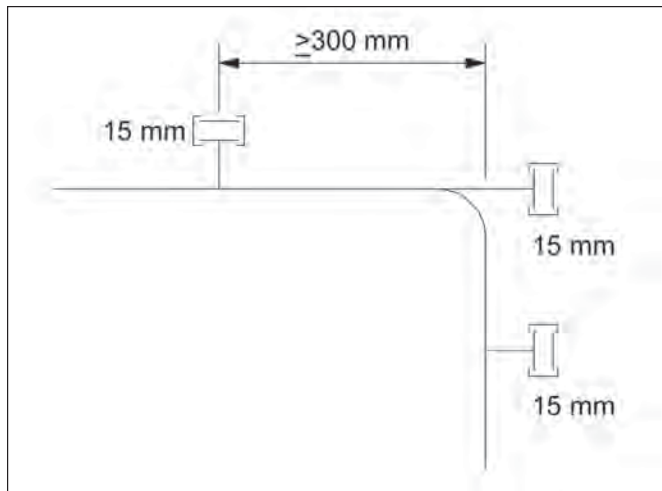

Figure 2. Typical HTM 2010 sampling arrangement.

- At each autoclave (as stipulated in the above standards)
- At each lyophilizer (not specified in the above standards, but good practice)
- At the PSG outlet. Normally, in the scope of the PSG supplier.

Three ½" hygienic clamp connections are required for these sample points. It is recommended to have an isolation valve immediately upstream and a pressure gauge to confirm that the line has been depressurized before clamp blind caps are removed to connect sampling equipment. It cannot be stressed enough that these sample points must be accessible. They are often installed as an afterthought and can then be extremely difficult to connect with the relevant sampling equipment. During the initial piping layout design, it must be anticipated to locate these sample points as close to the autoclave (or other equipment) as possible, but certainly within 2 or 3 meters.

These HTM 2010/EN 285 test points are used to take samples manually. Non-condensables are measured by condensing a quantity of steam and then measuring the volume of this which is water and the volume which is gas. Superheat is measured by routing steam through an expansion tube and checking that there is not an excessive temperature difference between that temperature and the main header temperature. Dryness is measured by condensing steam from the header. A typical HTM 2010 test connection is shown in Figure 2.

Note that the dryness HTM 2010 test in particular is very sensitive to entrained moisture, and if there are flaws in the design or installation of the pure steam distribution system, this is the test that is most likely to fail. Even if an upstream pipe has been stepped on during construction and bent (even if it is almost imperceptible to the naked eye) so that there is slight pooling of condensate in the line, this amount of condensate can be enough to make the system fail its dryness test.

## Air Venting

There are sources which recommend installing a high point trap for venting air out of the pure steam system. However,

this is not recommended for a continuously running pure steam system. While it is possible that a high point trap, such as this, will accelerate the de-aeration of the system, this is not a worthwhile gain for a system which will only be shut down and started up once or twice a year. It must be noted that once hot, air is heavier than steam and that thermostatic traps operate based on temperature. In other words, the low point steam traps will pass air until the system is de-aerated. These types of high point air vents can make sense in plant steam systems which use thermodynamic or float traps which are based on velocity and density respectively (i.e., will not pass air), but do not make sense for a distribution system which uses thermostatic traps throughout.

Furthermore, the ideal location of the high point venting trap is frequently in a very inaccessible location at the top of the building, often at the top of a pipe rack. Over time, these traps can begin to leak. If the trap begins to leak, it will have to be removed for maintenance. Since these are generally difficult to access, they are often permanently removed after they have leaked a few times.

## Conclusion

The above article is intended as a guideline to some of the key issues to consider when designing a pure steam generation and distribution system. In particular, it aims to discuss many of the contentious issues which come up repeatedly in the design of pure steam systems. However, it is recommended to seek the advice of a professional designer when designing or modifying such systems.

## References

1. EN 285:2006 Sterilization. Steam Sterilizers. Large Sterilizers.
2. Health Technical Memorandum (HTM) 2010 Crown Copyright 1994.
3. ISPE Baseline® *Pharmaceutical Engineering Guide, Volume 4 - Water and Steam Systems*, International Society for Pharmaceutical Engineering (ISPE), First Edition, January 2001, <http://www.ispe.org>.
4. ASME BPE 2007 Bioprocessing Equipment.
5. United States Pharmacopoeia 32-NF27, 1 November 2009.

## About the Author



**Hugh Hodkinson** is a Lead Process Engineer for DPS Engineering. Educated at University College Dublin, he holds a BE in chemical engineering. He has been with the company since 1999 and has led aseptic design projects in Ireland, the UK, and the Netherlands. His experience includes a variety of facilities for vaccine production, cell culture production,

downstream processing, and fill finish products. He can be contacted by telephone: +353-86-8185589 or by email: [hugh.hodkinson@dpseng.com](mailto:hugh.hodkinson@dpseng.com).

DPS Engineering, Landscape House, Baldonnell Business Park, Baldonnell, Co. Dublin, Republic of Ireland. 

# New ISPE Online Learning Programs



## Three new categories

of programs are now available as part of ISPE's expanding Online Learning library. Available for download anytime, these programs provide cost-effective learning solutions, especially for professionals experiencing travel and budget restrictions.

### 2009 Washington Conference Series

---

Video recordings of ISPE education sessions are available for those who missed an event, or those who want to experience it again. The 2009 Washington Conference Series features topics such as global supply chain integrity, validation and quality by design, and discussions with numerous global regulators — including those from the U.S. Food and Drug Administration.

### **Certified Pharmaceutical Industry Professional™ (CPIP™) Online Courses**

---

Self-directed courses providing a broad range of learning opportunities for career growth and professional development. They target two groups: those interested in general pharmaceutical industry knowledge on topics ranging from drug product development to manufacturing, and those seeking industry-wide recognition for accumulated experience by obtaining the CPIP credential.

### **Good Manufacturing Practice (GMP) Online Courses**

---

A series of interactive pre-recorded courses reviewing the pre-approval and post-approval USFDA GMP inspection approach for quality, facilities/equipment, laboratory, materials, packaging/labeling, and production systems.

Visit [www.ISPE.org/onlinelearning](http://www.ISPE.org/onlinelearning) to learn more, and to download and search the new ISPE Online Learning Catalog.



This article presents the advantages and disadvantages of distillation-based and membrane-based methods for producing WFI, outlines international WFI regulatory requirements, discusses historical market penetration and performance of distillation and membrane-based WFI systems, and includes a membrane case study.

## Methods of Producing Water for Injection

by Henry Brush and Gary Zoccolante

### Introduction

**W**ater For Injection (WFI) international pharmacopoeial standards have been brought closer through harmonization efforts, but significant differences still exist. The USP WFI monograph allows production by “distillation or a purification process proven to be equal to or superior to distillation.” USP language is the least restrictive in terms of acceptable processes among the major pharmacopoeial groups. The Japanese Pharmacopoeia (JP) allows distillation or Reverse Osmosis (RO) followed by UltraFiltration (UF). Distillation is the only WFI method of production that is approved by the European Pharmacopoeia (EP).

Historically, distillation has been the preferred method for producing WFI in the biopharmaceutical industry, and today, most pharmaceutical WFI is produced by distillation. Regulatory requirements have helped significantly in the domination of WFI production by distillation, but distillation also has

been successful in attainment of the water quality specifications. Yet, most other high-purity industries use reverse osmosis, deionization, and ultrafiltration, not distillation, to produce WFI equivalent or higher quality water. ASTM Type A laboratory water limits for total bacterial count and endotoxin are respectively ten and eight times lower than WFI. ASTM Type 1.2 water for microelectronics has similar microbial restrictions with total organic carbon and conductivity limits well below WFI. Those applications are routinely satisfied with membrane-based systems producing water at ambient temperature. However, those industries do not have regulated process limitations.

This article will discuss the advantages and disadvantages of distillation-based and membrane-based methods for producing WFI; outline international WFI regulatory requirements; and discuss historical market penetration and performance of distillation and membrane-based WFI systems. Also included is a membrane case history from US biopharmaceutical company Alkermes, Inc.

Table A. WFI Requirements for USP, EP, JP.

	USP	EP	JP
Method of WFI Production	Distillation or purification process proven to be equal to or superior to distillation	Distillation only	Distillation or RO/UF
Conductivity, $\mu\text{S}/\text{cm}$ @ 25 °C or equiv. @ other temps.	1.3	1.3	1.3
TOC, ppb	< 500	< 500	< 500
Endotoxin	0.25 EU/mL	0.25 EU/mL	0.25 IU/mL
Bacteria, cfu/100 mL	10	10	10
Nitrates, ppm	N/A	0.2	N/A
Ammonium, mg/L	N/A	N/A	0.05

### Distillation-Based WFI Systems

To meet USP requirements, WFI must be produced by “distillation or a purification process proven to be equal to or superior to distillation.” Additionally, the water must pass conductivity and Total Organic Carbon (TOC) tests, and the bacteria endotoxin level must be below 0.25 endotoxin units per milliliter (EU/mL). The microbial level must not be above 10 Colony-Forming Units (CFU) per 100 mL. Distillation is effective at quantitative reduction of most water contaminants and can produce water with low conductivity,

*Continued on page 22.*

A photograph of an iceberg in the ocean. The visible tip is a small, white, pointed shape. Below the surface, a much larger, dark blue, and jagged mass of ice is submerged, illustrating the concept of hidden depth. The sky is a clear, deep blue.

# How can I find real depth in cost-effective water solutions?

## **With Siemens, cost-effective solutions are just the tip of the iceberg.**

Siemens Water Technologies provides the largest portfolio of innovative solutions that get below the surface of all your plant's needs. Our reduction, reclaim and reuse approach helps your plant's water and energy conservation efforts, drastically reducing costs and waste production while meeting ever-increasing regulations. And with the most validated and non-validated pharmaceutical installations around the globe, experienced service teams, and fully functional factory acceptance tests (FAT), product safety and reliability are ensured, and profitability is maximized. Count on Siemens to provide more than just the tip of the iceberg. For more information, call 800.875.7873 ext. 5000 or visit [www.siemens.com/iceberg](http://www.siemens.com/iceberg)

Answers for industry.

**SIEMENS**



low TOC, low microbial levels, and low endotoxin levels.

Almost all pharmaceutical distillation-based systems implement either multiple effect or vapor compression stills. Both still types employ various techniques for recovery of latent and sensible heat to minimize energy consumption. Both technologies produce WFI quality water when properly implemented and operated. Each still type has advantages and disadvantages and each has significant successful operational history.

While stills are reliable, they are not perfect, and can produce pyrogenic product water when operated incorrectly, when they fail mechanically or when the feed water contains contaminant levels beyond the still reduction capability. If fed with high endotoxin feed water from the raw supply or pretreatment equipment, in cases where there is no membrane-based system pre-treating the still, the product water from the still may fail the endotoxin test. Many successful distillation systems exist with no membrane pretreatment, but several other systems have required retrofit of Reverse Osmosis (RO) or UltraFiltration (UF) pretreatment after periodic product water endotoxin failures due to high still feed endotoxin levels.

The FDA Guide for Inspections of High-Purity Water Systems recognizes the still pretreatment design question regarding potential use of a membrane process. Section V of the Guide states, "Many of the still fabricators will only guarantee a 2.5-log to 3-log reduction in the endotoxin content. Therefore, it is not surprising that in systems where the feed water occasionally spikes to 250 EU/mL, unacceptable levels of endotoxins may occasionally appear in the distillate (WFI). For example, three new stills, including two multi-effect, were recently found to be periodically yielding WFI with levels greater than 0.25 EU/mL."

The FDA Guide further states, "Pre-treatment systems for the stills included only deionization systems with no RO, ultrafiltration, or distillation. Unless a firm has a satisfactory pre-treatment system, it would be extremely difficult for them to demonstrate that the system is validated."

The decision to implement or not implement reverse osmosis in still pretreatment is generally more relevant to vapor compression stills than multiple effect stills. Vapor compression stills operate at a lower temperature than Multiple-Effect (ME) stills and are less susceptible to chloride stress corrosion and scale; therefore, reverse osmosis is not always necessary for scale and corrosion prevention. Multiple effect stills generally require feed water with low levels of chloride, silica, and total solids, and are almost always pretreated with reverse osmosis and/or an ion exchange process. Since reverse osmosis is present in almost all ME still feed systems, the feed endotoxin levels are quite low.

## **Vapor Compression Distillation**

Vapor compression distillation systems generally implement scale control, dechlorination, and in some cases, reduction of ionized solids and/or endotoxin. A vapor compression distillation system often consists of softening, heat exchanger, hot-water-sanitizable activated carbon, prefilter, optional hot-

water-sanitizable RO, and finally, a vapor compression still. The key design consideration is inclusion or exclusion of RO.

RO is excluded when ionized solids and endotoxin reduction is not deemed necessary for reliable, consistent attainment of WFI quality parameters. RO is implemented when the user believes that reduction of endotoxin and ionized solids in the still feed assures that WFI quality is consistently attained, maintenance is minimized, and hot blowdown is minimized. Many systems of both types are in operation. If only endotoxin reduction is desired in the still pretreatment system, UF may be substituted for RO.

In addition to meeting all pharmacopoeial requirements, vapor compression distillation offers the following advantages:

- generally reliable operation
- typically more energy efficient than multiple-effect distillation
- can be operated on softened/dechlorinated feed
- may not require a complex system design
- relatively low maintenance

Potential disadvantages of vapor compression stills include:

- may be more labor intensive than multiple-effect distillation with compressor and associated drive gear
- may have higher life cycle cost than membrane based systems

## **Multiple-Effect Distillation**

A Multiple-Effect Distillation (MED) system often consists of a multi-media filter, softening, break tank, heat exchanger, hot-water-sanitizable activated carbon, prefilter, optional pH adjustment, 254-nanometer ultraviolet (UV) light, hot-water-sanitizable RO, continuous electrodeionization (CEDI), followed by the multiple-effect distillation unit. The pretreatment system is generally comprehensive because the high operating temperature makes MED stills susceptible to chloride stress corrosion and scale. The pretreatment system typically minimizes chloride, silica, and total dissolved solids levels. Membrane based pretreatment typically reduces endotoxin to very low levels, such that the still endotoxin challenge is negligible.

- In addition to meeting all pharmacopoeial requirements, multi-effect distillation has the advantage of few moving parts and this can minimize maintenance requirements.

Potential disadvantages include:

- generally requires high-quality feed water: less than 0.5 ppm chloride; less than 1.0 ppm silica; less than 5.0 µS/cm conductivity
- typically higher energy costs than vapor compression distillation
- typically higher cooling water requirements than vapor compression

*“Most alternative designs to distillation have used one or two passes of RO, often with an ion exchange process and in virtually all cases, final polishing with UF or RO. The system designs over decades have been driven by practicality and regulation.”*

- may have higher life cycle costs than membrane-based system

### What Other Treatment Methods Work?

A number of separation methods, such as RO and UF, can remove endotoxin. Oxidation with ozone also removes endotoxin. Heat, distillation, UF, RO, filtration, ozone, UV, and chemical methods can all achieve low microbial levels in the product water. Other market applications, such as microelectronics and select laboratory water types have water quality specifications far tighter than WFI including extremely low endotoxin limits. Almost all of these systems utilize membrane technologies for primary treatment. Membrane systems may offer lower operating economics as no water evaporation occurs. Systems either operate at ambient temperature normally or are heated to high temperature without evaporation and condensation. The content of stainless steel is often less with membrane systems compared to distillation.

### Membrane-Based WFI Systems

Most alternative designs to distillation have used one or two passes of RO, often with an ion exchange process and in virtually all cases, final polishing with UF or RO. The system designs over decades have been driven by practicality and regulation. The first alternative to distillation allowed by USP decades ago was RO. RO technology was generally not up to the task of consistent WFI performance and the technology did not flourish. Hot water sanitizable membranes did not exist and chemical sanitization was often inconsistent, allowing periodic microbial excursions beyond WFI specification. Some validated systems existed, but placements were few.

The presence of membrane systems was enhanced when the Japanese Pharmacopoeia allowed RO followed by UF as an alternative to distillation. Hot water sanitizable and continuous hot ultrafiltration elements were available and contributed to successful operation. Ultrafiltration had a lengthy, successful history in pharmaceutical manufacturing and was accepted. This technology change led to implementation of more systems that produced “WFI quality” water where pharmacopoeial WFI compliance was not required.

The change by USP to open WFI production to “distillation or a purification process proven to be equal to or superior to distillation” has helped to increase interest in membrane based WFI systems.

EP has created a monograph for Highly Purified Water with no process limitations and water quality specifications identical to WFI. This has helped to increase membrane system placement for production of “WFI quality” water.

Two-Pass RO (TPRO), also known as product staged RO, was one of the earliest WFI membrane configurations. TPRO

systems were more popular prior to the presence of conductivity and TOC tests. At that time, the USP WFI monograph only allowed distillation or RO for process and it was accepted that the still or RO would be the terminal process. The FDA had noted in “The FDA Guide for Inspections of High-Purity Water Systems” that if RO was used for WFI, two stages should be used to assure attainment of the quality specifications. TPRO can typically meet all of the required water quality parameters, but consistent attainment of Stage 1 conductivity can be an issue with some feed waters. TPRO systems often consist of a multi-media filter, softening, break tank, heat exchanger, hot-water-sanitizable activated carbon, prefilter, optional pH adjustment, 254-nm UV, and two stages of hot-water-sanitizable reverse osmosis.

The implementation of a WFI conductivity test requirement and the liberalization of the USP WFI allowable processes increased use of systems implementing reverse osmosis, ion exchange processes, and ultrafiltration or a final stage of RO. The logic of this type of system configuration is that the combination of reverse osmosis and ion exchange easily meet the conductivity and TOC specifications while the final ultrafilter or RO stage assures compliance with the endotoxin and microbial requirements. Systems of this type have had a lengthy history in production of “WFI quality water” prior to acceptance as a method to produce WFI to pharmacopoeial standards. The basic system capability for production of water with low contaminant levels has been long proven in other markets, such as microelectronics, for decades.

Most membrane based systems have several components that are either intermittently hot water sanitized or maintained continuously at a self sanitizing high temperature. Some systems have a final membrane stage that operates at the same elevated temperature as the storage and distribution system. Several systems of this type have been in operation for more than 10 years with water quality performance equivalent to distillation based systems.

A typical membrane based WFI system includes dechlorination, softening, a hot-water-sanitizable RO device followed by a hot water sanitized CEDI device. A continuous hot-water UF device polishes the water prior to storage and use as WFI if the water will be stored hot. A hot water sanitized UF or RO serves as the final stage if the product water will be stored at ambient temperature. Advantages of using RO/RO or RO/UF to produce WFI are as follows:

- may be the lowest life cycle cost alternative
- typically low energy requirements
- typically very low conductivity, TOC, endotoxin, and microbial levels
- generally reliable operation

*Continued on page 24.*

- can be intermittently or continuously hot sanitized
- there is some history in the U.S. Pharmacopeia and Japanese Pharmacopoeia of using RO and UF for WFI

The most significant disadvantage is that EP does not allow a WFI production method other than distillation and therefore, WFI membrane use is limited to non-EP applications. The history of membrane based WFI system usage is significantly less than with distillation, and this has negatively affected confidence in membrane systems among some pharmaceutical companies. Additionally, the RO system requires periodic cleaning, the membranes must be replaced at some point, and membranes can fail just as any technology has failure mechanisms.

Capital and operating cost comparison for distillation and membrane based systems is a key element of system choice when regulatory requirements do not dictate distillation only. This article does not provide costs for several key reasons. Equipment specifications for materials of construction, instrumentation, control, and other major cost factors impact capital costs significantly and capital costs are meaningless without detailed specifications. Operating costs are directly impacted by utility costs for water, wastewater, power, steam, chilled water, and others and vary tremendously site to site. These costs are best based upon actual conditions case to case for accurate analysis. The significant possibility of lower life cycle economics for membrane based systems is based upon the relative absence of distillation based systems in non-regulated high purity applications.

## Why Has Membrane-Based WFI Production Failed to Flourish?

With all the potential advantages of using membrane-based technologies for producing WFI, why has it not caught on in the industry? For one reason, when RO was first approved for use in WFI production, the technology was not completely “ready” for this application. Hot-water-sanitizable RO did not exist, and chemical sanitization is not as effective as heat. Full-fit RO membrane elements were not available and neither was continuous hot operation. Early failures discouraged use, and while endotoxin control was not a problem, microbial control was. Ultrafiltration technology, while “ready,” did not have USP or EP approval.

Membrane technology has a significant successful history in production of WFI in Japan and in the US, but membrane system implementation is limited to facilities or applications where the EP requirements are not a factor. Since a significant percentage of pharmaceutical manufacturers produce for the European market, the EP distillation requirement stifles membrane implementation.

## Conclusions

Most WFI systems are distillation based. Distillation has a lengthy successful history in WFI production. Most other high purity systems in other markets use membrane processes rather than distillation, but no regulatory requirements exist. Water quality specifications for use such as microelectronics

manufacturing often greatly exceed WFI quality requirements.

USP and JP allow membrane based designs as well as distillation. The EP requirement for distillation eliminates any choice of alternate technologies for companies wanting to comply with EP. Therefore, membrane based systems are only employed where EP compliance is not required or where “WFI quality” water is desired, such as for meeting the requirements of EP Highly Purified Water, preparation of intermediates, or other uses.

Although some successful membrane-based systems have been in operation for several years, the historical database is not nearly as large as for distillation. Membrane-based systems are beginning to be placed and are considered more frequently because membrane-based systems may offer lifecycle cost advantages in reduced capital or operating costs. The choice is one of many risk-based decisions in the pharmaceutical industry. Users need to consider product, market, capital cost, utility costs, commissioning/qualification, maintenance, and risk to make an informed decision.

## Case Study for WFI Production: Alkermes, Inc.

The following case study is for a membrane-based WFI system in a US facility. A case study for distillation is not presented because distillation is well established. The distillation operating history is generally good and advantages and disadvantages are well understood.

### Background

Alkermes pulmonary drug delivery platform technology enables delivery of both small molecules and complex macromolecules to the lungs. This system can provide efficient dry-powder delivery of small molecule, peptide, and protein containing drug particles to either the deep lung or the upper respiratory tract, based on the product needs. Alkermes designed and built a manufacturing facility to support production of late stage clinical supplies as well as commercial production of its pulmonary drug delivery products. The manufacturing operations at the site include spray drying to produce the bulk dry powder, capsule filling, packaging, CIP systems for cleaning, and a clean steam system. The purified water system was designed to support the formulation activities associated with production of the bulk powder in the spray drying operation, the CIP system for cleaning process equipment, and as feed water to the clean steam system.

### Introduction

Dry powder inhalation products are typically not produced under aseptic manufacturing conditions. Based on this, the initial project requirements specified USP Purified Water as the appropriate grade of water for the manufacturing site. This decision was revisited after detailed engineering had been completed on the project. The review team identified a potential for tightening of microbial specifications in the final drug product, particularly for products that might be used in patients with compromised immune systems. Based on this

assessment, it was decided that the microbial specifications of the water should be tightened to support the current as well as any future drug product microbial and endotoxin requirements.

The water system had already been ordered and was in fabrication when the system requirements were changed. The Alkermes engineering team met with the system supplier to identify solutions that could meet the revised water system requirements, while minimizing the impact on the cost and schedule of the project. Several options were discussed, including the option of the reverse osmosis and continuous electrodeionization (CEDI) systems that were already specified as being able to meet the new requirements, and installation of a still to produce WFI grade water. The team identified the addition of an ultrafiltration step as the best way to meet the tightened water specifications, while minimizing the cost and schedule impact to the project. The system supplier was willing to guarantee that with the addition of an ultrafiltration step, the water generation system would be able to meet USP Water for Injection specifications with regard to microbial and endotoxin requirements.

The ultrafilter unit operation is relatively small physically and had a minimal impact on the layout of the generation and distribution system. This minimized any costs associated with piping layout changes. It also minimized the schedule impact because it did not require significant re-piping to accommodate the ultrafilter unit into the layout. The ultrafilter

unit and hardware also had short lead times, which further minimized the impact to the overall project schedule. In addition, the capital cost of the ultrafilter system was relatively small. This minimized the impact to the project cost.

### **System Description and Discussion**

The Alkermes water system is designated as an EP Highly Purified Water (HPW) System. The system consists of a generation system that is supplied with city water and produces up to 8 gpm of highly purified product water that meets USP, WFI test specifications. The product water is supplied from the HPW generation system to the top of a 3,000 gallon hot storage tank that is maintained at 80°C. The hot water storage loop is continuously circulated by pumping water from the bottom of the storage tank, through a heat exchanger, and back into the top of the storage tank. If the storage tank is full, the product water is circulated back to the HPW generation system as feed water.

The HPW distribution loop is self contained and normally maintained at room temperature or 24°C. The HPW distribution loop and hot storage loop are connected so that when water is drawn from the distribution loop, hot water is supplied from the storage loop to the distribution loop. A heat exchanger in the HPW distribution loop cools the water prior to feeding the water out into the plant and to the use points. Every 24 hours the cooling heat exchanger is turned off and the HPW loop is heated to 80°C and held

*Continued on page 26.*

GE Water & Process Technologies  
Analytical Instruments

## Proven performance. Proven results.

### The wise choice for TOC when every dollar counts

For decades, major global pharmaceutical manufacturers have trusted **Sievers Total Organic Carbon (TOC) Analyzers** from GE Analytical Instruments to deliver cost savings, accurate results, and productivity enhancements. With today's tight budgets, minimizing risk and maximizing return on investment is critical. Sievers TOC Analyzer customers regularly report significant savings, including:

- An 82% reduction in TOC laboratory samples for USP water testing
- More than \$500,000 in cost savings from switching to on-line TOC analysis
- IOPQ execution in less than five days
- 92% cost savings in cleaning verification costs by moving to at-line analysis

Find out how we can help you improve your bottom line. Visit [www.geinstruments.com](http://www.geinstruments.com) or contact us at [geai@ge.com](mailto:geai@ge.com) or 800-255-6964.



imagination at work



Sievers TOC Analyzers — the safe, proven choice for accurate, reliable TOC testing

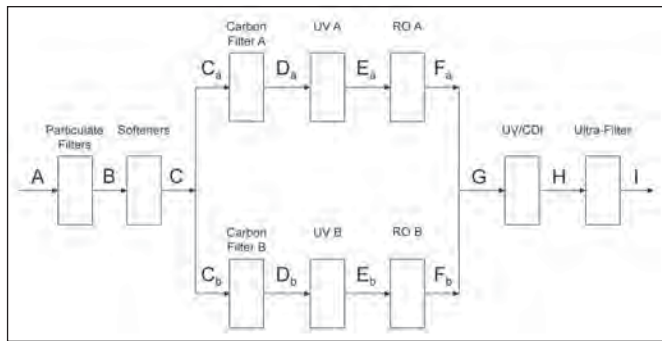

Figure 1. Process flow diagram for the HPW generation system.

at temperature for 60 minutes. The system design is based on the “Hot Storage – Self Contained Distribution” design that is described in the ISPE Baseline® Guide on Water and Steam Systems.

The overall water system includes several unit operations to meet the required product specifications. City water from the Massachusetts Water Resource Authority system is filtered using a multi-media filtering system to remove coarse particulates. The first unit operation in the HPW generation system is the particulate filter system. The particulate filters are nominal 5.0 µm cartridge filters designed to remove large particulates from the incoming feed water. The particulate filter system includes two banks of five cartridge filters, each of which can be operated in parallel with either one or two units in operation.

The next stage in the HPW generation system is a duplex water softening system. The water softening system is an ion exchange process that is designed to remove divalent and trivalent ions from the incoming city water and replace them with a monovalent sodium ion. The softening process prevents scale in the reverse osmosis unit downstream.

Two activated carbon filter skids in parallel are located downstream of the water softeners. The carbon filters are designed to remove chlorine from the feed water. Chlorine is added by municipal authorities to the city water as a microbial control agent. Chlorine can oxidize the reverse osmosis membranes and negatively impact system performance. In addition, it is recognized that the carbon beds can serve as an environment

for microbiological growth once the chlorine is removed. The heat sanitization cycles for the carbon filters are designed to control the bioburden levels in the carbon filters.

Ultraviolet (UV) lamp units are installed downstream of the carbon filters for inhibiting microbial growth after the chlorine has been removed by the carbon beds and prior to feeding the RO membranes with the in process water. The intensity of the UV lamps is monitored and documented in rounds sheets during routine operations of the system.

The next stage in the HPW generation system is the reverse osmosis process, which is part of the final treatment system. The system includes single pass RO membranes. The RO process is a pressure driven process with a semi-permeable membrane designed to remove minerals, organics, particulates, microbiological material, and endotoxin. The RO membranes reject a significant portion of the feed stream, while allowing a portion of the purified water stream to pass through the membrane. The daily performance of the RO membrane is monitored by measuring the percent rejection of conductive elements in the feed water to the reverse osmosis unit.

The CEDI unit is located downstream of the RO membranes and removes ionized species from water using electrically active media and electrical potential to effect ion transfer. The CEDI system is a continuous process in that the ions are continuously removed and the ion exchange resins are regenerated continuously. In addition, there is a UV unit as part of the CEDI skid. As discussed above, the UV unit is designed to limit microbial growth.

The last unit operation in the final treatment portion of the HPW generation system is the ultrafiltration system. The ultrafilter (UF) includes a 0.05 µm single pass filter and is designed to provide the final step in meeting the WFI specifications. Figure 1 includes a process flow diagram indicating the different unit operation steps in the HPW generation system.

Heat is used to sanitize both the HPW generation system and the HPW distribution system. The carbon filter, reverse osmosis skid, and associated piping are sanitized weekly using 80°C water. The entire generation system, including the carbon filter, RO skid, CEDI system, ultrafilter, and associated piping

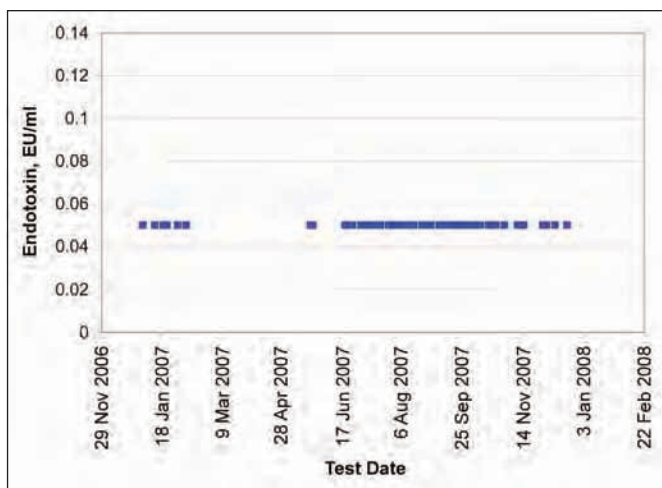

Figure 2. HPW generation system outlet.

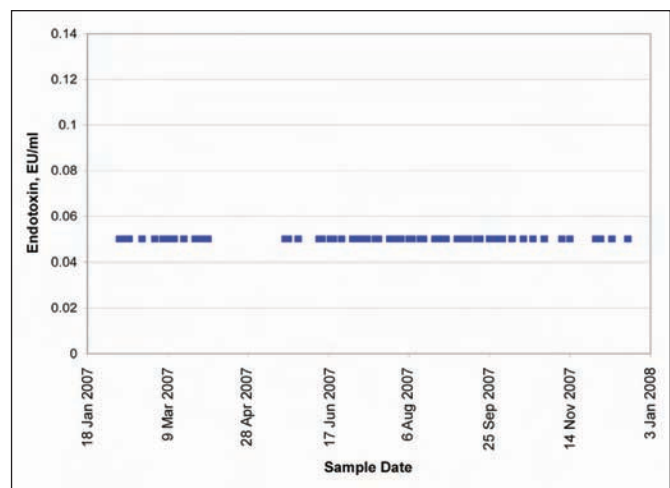

Figure 3. Formulation tank supply valve.

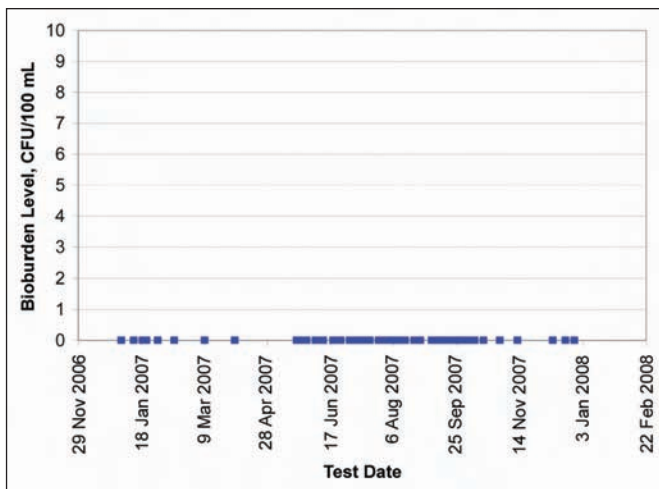

Figure 4. HPW generation system outlet.

is heat sanitized monthly. The distribution system is sanitized nightly by heating the entire distribution loop to 80°C.

The HPW generation and storage and distribution system was routinely monitored with a combination of inline and offline testing to confirm that the system was performing as expected. Critical performance attributes were identified for the unit operations within the generation system, along with appropriate test methods and acceptance criteria. The performance attributes were routinely monitored to confirm that the system was performing as expected. This includes, for example, routinely monitoring the free chlorine and bioburden levels after the carbon filter. In addition, the storage and distribution system was monitored at various points throughout the system. This included a rotating schedule of sampling various use points and testing for bioburden, endotoxin, conductivity, TOC, heavy metals, and nitrates. Appropriate specifications were established for the use point monitoring that included alert and action levels for the various attributes. Data and acceptance criteria are presented below.

### Data Discussion

As discussed above, the HPW was used for cleaning operations, clean steam feed water, and for formulation activities in producing dry powders used for inhalation therapies. Alkermes identified test attributes and specifications along with acceptance criteria that were appropriate for the intended use of the water. The specifications met the standards outlined for WFI compendial grade water.

The HPW storage and distribution system was sampled and tested on a routine basis to monitor the quality of the water. The schedule included sampling and testing of water from various points in the HPW storage and distribution system. Data is presented below from the January through December 2007 period that demonstrates the overall performance of the system. The data includes test points from the outlet of the generation system before the product water enters the storage and distribution system as well as at use points within the storage and distribution system.

Endotoxin test data is presented from two different sample points in the HPW system. Figure 2 includes data from the

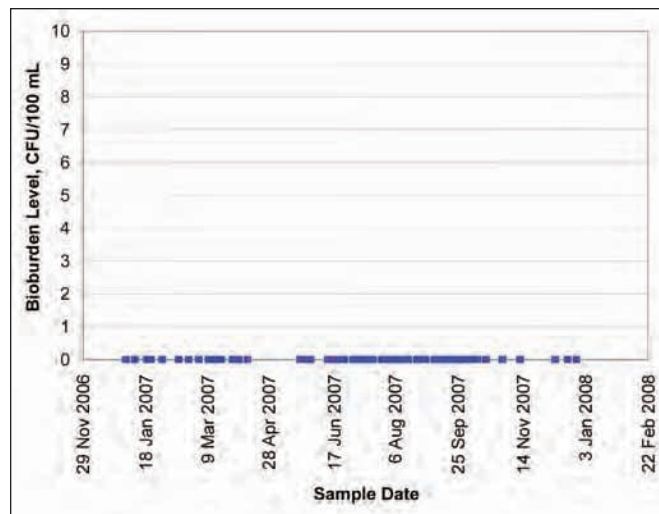

Figure 5. Formulation tank supply port.

generation system outlet. Figure 3 illustrates data from a charge port on the distribution system which is used to fill a formulation tank. In both cases, all samples were found to be below the detection limit of 0.05 EU/mL, which satisfies the alert limit of Not More Than (NMT) 0.13 EU/mL.

Total aerobic bioburden test data is presented from two different locations in the HPW system for the period January through December of 2007. Figure 4 includes data from the outlet of the HPW generation system. Figure 5 includes

*Concludes on page 28.*



**Murray Company**  
MECHANICAL CONTRACTORS

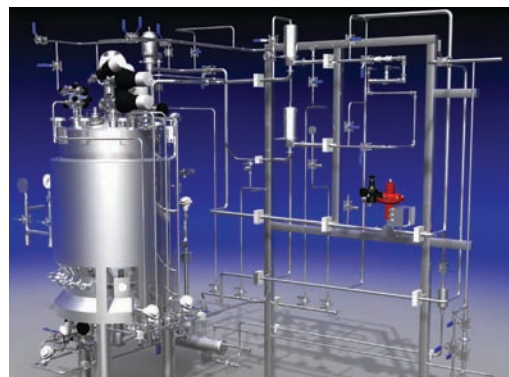

### A Proven High Purity Piping Contractor

Murray Company has built its reputation in the industry with our strong commitment to installing high purity piping and fabrication, as well as providing proven standard operating procedures tailored to FDA protocol with in-house Level 2 trained inspectors. We take pride in offering a turnover package that has been repeatedly praised by our clients for the ability to help expedite system validation. We ensure the quality of every project from start to completion.

2919 E. Victoria Street, Rancho Dominguez, CA 90221  
P 310.637.1500 • F 310.604.0359  
www.murraycompany.com

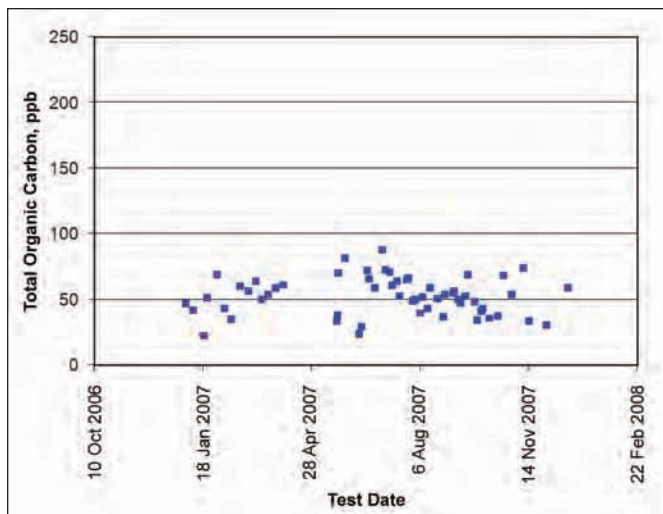

Figure 6. Formulation tank supply port.

data from a charge port on the distribution system, which is used to supply a formulation tank. In both cases, all test data from the ports were non-detectable for bioburden or below the alert limit of NMT 1 CFU/100 mL.

Total Organic Carbon (TOC) data is presented for the formulation tank charge port, which is located on the HPW distribution system. The data is plotted in Figure 6. The acceptance criteria include an alert limit of NMT 250 ppb. All values tested during the January to December 2007 period were below the alert limit of 250 ppb.

## Conclusions

This case study presented data demonstrating that WFI can be produced using a membrane-based water purification system. Monitoring data from a calendar year are presented for several critical performance attributes of the HPW generation and distribution system. All of the critical performance attributes met the standards outlined for WFI compendial grade water.

A membrane-based water purification system was chosen to minimize cost and schedule impact when the design basis was changed during the construction phase of Alkermes' manufacturing site. The addition of an ultrafiltration unit operation, which is compact in size, minimized the impact on the design and layout of the overall water system. The ultrafilter had a relatively short lead time and the capital cost was low. In addition, the operating cost of the ultrafiltration unit is significantly lower than the operating cost of a still, minimizing the impact on operating costs.

## About the Authors



**Henry Brush** is the Director of Manufacturing and Process Development at Alkermes, where he has developed the manufacturing process technology for the pulmonary drug delivery platform. This includes leadership roles in the scale-up of the manufacturing process to a high volume commercial operation, clinical

production operations, manufacturing plant design and commissioning, and manufacturing technical support. Prior to Alkermes, Brush has developed manufacturing technology at Acusphere, PerSeptive Biosystems, and Polaroid. Brush is currently a member of ISPE and has served on the Board of Directors for the ISPE Boston Chapter. He received his BS in materials science and engineering from MIT, and his MS in chemical engineering from Northeastern University. He can be contacted by email: [brush@alum.mit.edu](mailto:brush@alum.mit.edu).

Alkermes Inc., 88 Sidney St., Cambridge, Massachusetts, 02139-4137.



**Gary Zoccolante** is Pharmaceutical Technical Manager at Siemens Water Technologies. He has more than 30 years of experience in the design, operation, and trouble-shooting of pharmaceutical water systems, and has been involved in the development of equipment for pretreatment, reverse osmosis, deionization, ultrafiltration, and distillation. Zoccolante

was a task team member of the original ISPE Baseline® Water and Steam Systems Guide and is part of the task team currently updating the guide. He has been part of the Guide Presentation Team on several occasions. He was involved in face-to-face meetings with the FDA to help resolve many of the Guide principles. He is a member of the ISPE Critical Utilities Community of Practice Steering Committee. He worked on the development of the ISPE Good Practice Guide: Commissioning and Qualification of Pharmaceutical Water and Steam Systems. He has been selected to deliver the first public presentation of the Guide. Zoccolante developed the four day ISPE Pharmaceutical Water course and has presented the course to hundreds of pharmaceutical industry personnel, including the FDA. He is a frequent lecturer for many pharmaceutical groups and has chaired many courses. He has presented for ISPE, Interphex, American Institute of Chemical Engineers, American Society of Mechanical Engineers, Institute for International Research, Center for Professional Advancement, PDA, Pharmtec, Barnett International and many others. He has conducted several in-house courses on pharmaceutical water production and regulatory requirements for pharmaceutical companies. He has authored and co-authored many papers on pharmaceutical water production and system operation and maintenance. He holds several patents for pharmaceutical water processes. He has previous experience as manager of engineering and manager of application engineering. He holds a BS in mechanical engineering from Northeastern University. He can be contacted by email: [gary.zoccolante@siemens.com](mailto:gary.zoccolante@siemens.com).

Siemens Water Technologies Corp., 10 Technology Dr., Lowell, Massachusetts 01851-2728. 

INTERPHEX



# INTERPHEX™

## Conference & Exhibition

*Connecting Life Science Professionals Globally*

- *World Class Exhibitors & Attendees*
- *Comprehensive Education Programs*
- *Face-to-Face & Online Networking*

**NEW YORK**  
[www.interphex.com](http://www.interphex.com)  
 April 20-22, 2010  
 Jacob K. Javits Center  
 New York, New York

**PUERTO RICO**  
[www.interphexpuertorico.com](http://www.interphexpuertorico.com)  
 March 4-5, 2010  
 Puerto Rico Convention Center  
 San Juan, Puerto Rico

**CANADA**  
[www.interphexcanada.com](http://www.interphexcanada.com)  
 September 16-17, 2009  
 Metro Toronto Convention Center  
 Toronto, Ontario



[www.interphex365.com](http://www.interphex365.com)

- Industry News
- Global Supplier Directory
- Meetings & Events
- Education & Training
- Community
- Careers

*Year Round Industry Access*  
[www.INTERPHEX.com](http://www.INTERPHEX.com)



Sponsored By:



Media Sponsors:







This article describes Amplified Media Circulation (AMC), which is an alternative option to the use of intrinsic sterilizer fans.

## Amplified Media Circulation – A New Way for Enhancing Sterilization Cycles

by David A. Karle, Gerald McDonnell, and Teppo Nurminen

### Introduction

Any mechanical moving part in a clean environment can present unique challenges to a manufacturing facility. For example, in the terminal sterilization of fluids, the associated sterilizer moving parts can include conveyors (for loading/unloading of the chamber) and impellers (or fans) within the sterilization chamber for heating/cooling purposes. Sterilizer fans are widely used to optimize the steam sterilization of loads (e.g., for providing laminar steam and air flow for good temperature distribution or for enabling enhanced cooling times), but are a particular problem as they are enclosed within the chamber of steam sterilizers. In addition to the requirement for emission-free operation for the fans, the hot, moist, pressurized conditions associated with steam sterilization result in an extra stress on these mechanical devices to include the bearings, shafts, and in the routine maintenance (e.g., lubrication) of such components. Further, chamber penetrations associated with fans require extra design requirements and utility supply, e.g., ultra pure water or distillate

for sealing purposes in powering the fans. Even with magnetic coupling technology, problems with particulate emissions, lubricant contamination, and bearing endurance can be a concern with traditional fan designs. In this article, an alternative option to the use of intrinsic sterilizer fans is presented, which is referred to as Amplified Media Circulation (AMC).

### Alternative Method and Design

Recently, a new method for enhancing air, steam, liquid, and/or gas movement in sterilization processes has been developed. The movement of air or other process fluids within a chamber, such as steam, can be amplified by methods other than mechanical agitation (the use of fans). An example is using the “venturi” effect. The venturi effect is actually a rather old concept, named after the Italian physicist Giovanni Battista Venturi (1746-1822). It is based on the premise that a high-speed liquid or gas generates a local vacuum through the kinetic energy of the flowing molecules. Although this might not be obvious, this phenomenon is used in many common devices, such as car carburetors, gas stoves,

Figure 1. Principle of venturi effect.

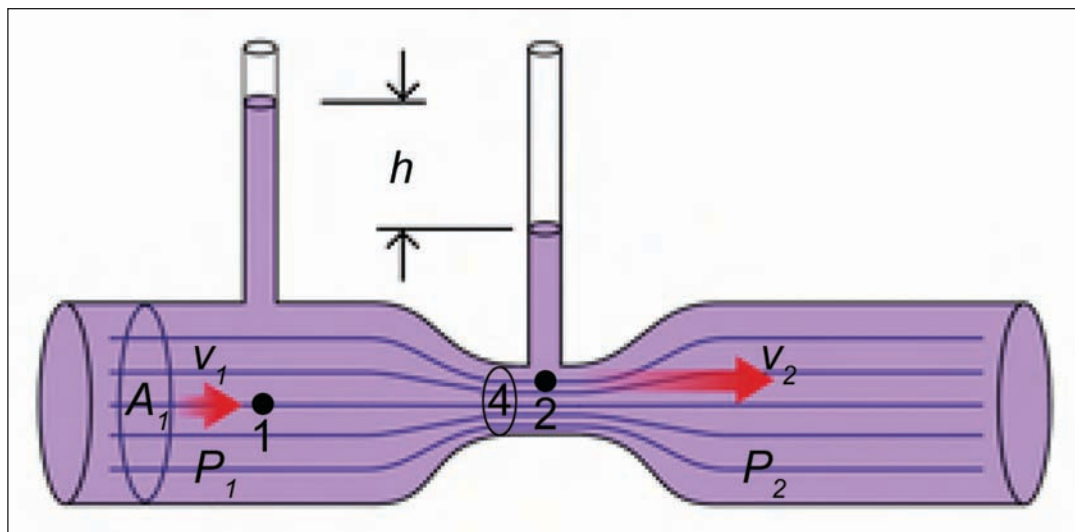

Continued on page 32.

# Pharmaceutical Processing Systems

GEA Pharma Systems supplies the world's pharmaceutical companies with state-of-the-art solutions for the processing of active pharmaceuticals, ranging from the processing of API (Active Pharmaceutical Ingredient) to the production of solid dosage forms and sterile liquids finishing.

The GEA Pharma Systems portfolio of leading industry brands includes:

- Aeromatic– Fielder and Collette granulation/drying systems
- Buck contained materials handling systems
- Courtoy advanced tablet presses
- Niro spray drying technology
- Lyophil freeze drying systems including automatic loading and unloading

The combination of these strong brands with a deep commitment to research and development has resulted in GEA Pharma Systems establishing a leading global market position.



Engineering Excellence.

## GEA Pharma Systems

9165 Rumsey Road • Columbia, MD 21045  
Tel 410 997 7010 • Fax 410 997 5021  
E-mail [info@niroinc.com](mailto:info@niroinc.com) • Website [www.niroinc.com](http://www.niroinc.com)

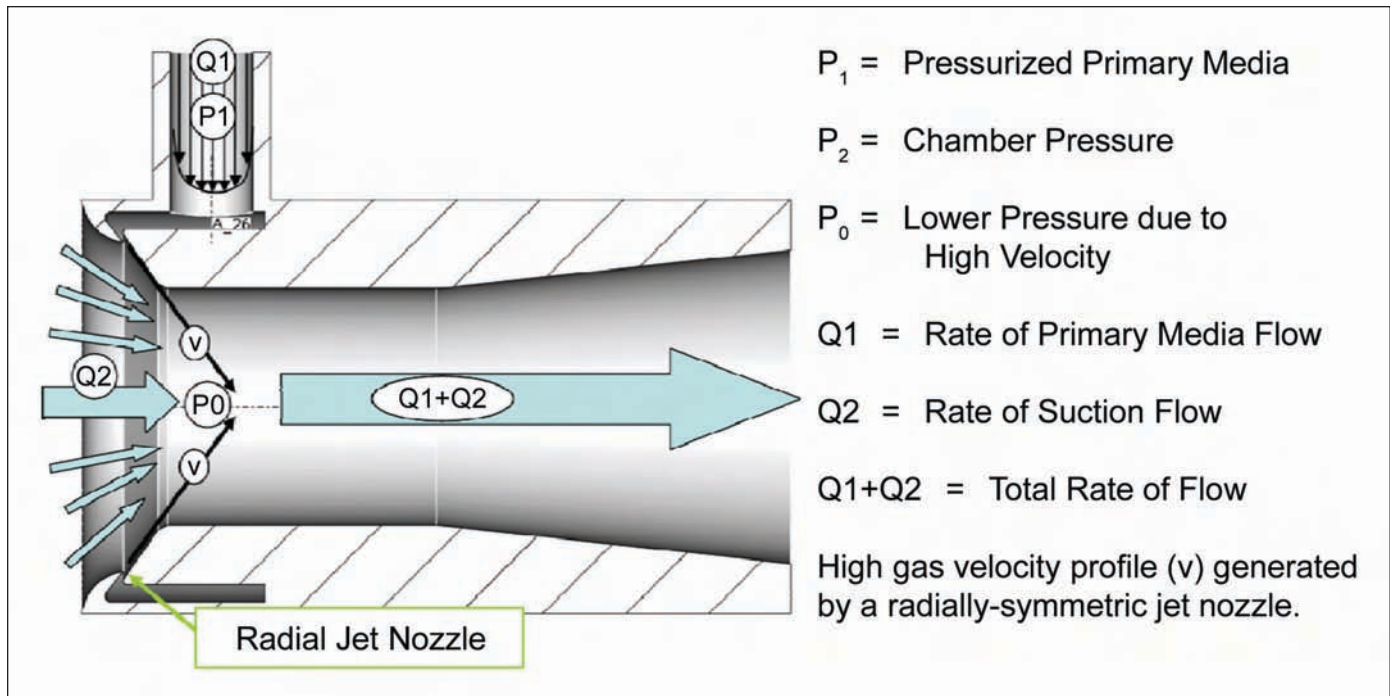

Figure 2. Principle of the AMC ejector.

or paint atomizers. In Figure 1, the venturi effect manifests itself as the hydrostatic pressure difference (h) between high and low velocity areas of the demonstration device.

For specific application to enhanced sterilization cycles, AMC differs from the traditional venturi pipe system due to the configuration of the associated flow channels. Whereas in a basic venturi design the primary flow in the main channel induces a negative pressure component into the side channel(s); in the case of AMC for sterilizer applications, the channel arrangement is the opposite. Primary media (like air) is injected into a narrow side channel, from which it flows into the main channel through a radially-symmetric capillary gap at the inlet end of the channel. The concave shape of the final section of the side channel redirects the flow, making it enter the main channel in a skewed angle, pointing toward the other end (outlet end) of the channel - *Figure 2*. The subsequent angled flow generates a local vacuum into the main channel. This vacuum draws air (or other fluid) into the inlet end of the main channel, and as a result, the combined main flow (priming air and venturi-induced main flow) is typically about 20 to 30 times higher in volume flow rate than the primary flow was. In this way, the higher pressure in the compressed air supply is converted into higher, "amplified" flow rates in the main channel.

The primary air needed for powering the AMC device(s) can be taken from any source; for example, a typical steam sterilizer air supply. The air quality requirements are the same as for any air-powered process component, being dry, oil-free, and passed through a 0.22 micron filter to ensure its sterility. This arrangement is practically no different than any other terminal steam-air-mix sterilizing process or any associated liquid process for that matter since all of these require air to provide and maintain over-pressure. For example, in the sterilization of closed liquids, a pressure higher than saturated

steam pressure is routinely applied in order to maintain product integrity. Producing compressed air is relatively inexpensive, especially when compared to the requirements for producing distillate or similar quality water for fan installations. In sterilizer applications, the AMC devices' primary air consumption is typically from 22 to 72 m<sup>3</sup>/h at 4 bar working pressure (equaling 13-32 cfm at 58 psig), depending on the sterilizer size. These values are essentially equivalent to the typical air pressure required for an associated sterilization process, i.e., any process designed for processing liquid loads. The difference is that with AMC, the peak consumption is sustained throughout the cooling stage and the air compressor should be able to support this level of air consumption on a continuous basis. Essentially, this can be achieved when planning the utilities for process support to verify that the compressor capacity for generating required amounts of pressurized air exists. In a medium or large plant, these rates would not be considered unusual or high, and in most cases, an existing compressor would already possess the additional capacity required. As energy consumption is always a consideration, it is important that the additional electrical energy consumed by air compressor is below that of the energy consumed by most conventional fan motors; this is despite the fact that the AMC approach does not require the pure water supply for sealing the required penetration. Typically, the cost of the electrical energy consumed is estimated to be around one dollar (\$0.33 - \$1.13 or 0.25 - 0.85 € depending on the chamber size) for each cooling hour.

Utilization of AMC devices is not limited to process air. Steam also can be injected into the chamber through such devices, which also may be considered as "ejectors," which can result in enhanced temperature distribution and shortened heating up times. Steam itself can be efficient in its own

right, but nevertheless a definite improvement in heating up times can be witnessed when the steam flow was amplified by directing it through AMC devices. Also, the higher the steam velocities, the more dynamic and effective the penetration into the load items can be. As stated in a steam sterilizer validation guide, "determining which load items are the most difficult to sterilize and which location(s) within the items presents the worst-case conditions can be a daunting task."<sup>2</sup> Steam penetration speed during standard operating conditions can be calculated. Calculations are based on simple diffusion and convective flow,<sup>3</sup> but dynamic disturbances improve the penetration further by agitating the atmosphere mechanically. Consequently, in order to achieve an optimal performance, arrangements can be made for toggling the utility supplies automatically between ejector/no ejector inlets based on the process phase. Figure 3 illustrates a typical ejector pair installation in the ceiling of the sterilizer chamber.

### Practical Applications

An example of the practical use of the AMC principle has been shown for the rapid cooling of liquid loads. Figure 4 presents a typical liquid load with sealed bottles. A traditional, indirect (jacket) cooling of such load can take many hours. Enhanced with fans or other mechanical devices, the cooling stage can routinely be shortened by 50 to 60%. The AMC system meets or even exceeds the performance of currently used mechanical convection systems (fans), but does not possess any of their



Figure 3. Ejector installation in the sterilizer ceiling.

associated disadvantages. Figure 5 presents tests results with unaided natural cooling, indirect jacket cooling, fan-enhanced cooling, and cooling assisted with AMC.

Ejector design and function can be maximized for optimal performance and programmed permanently for that application. An added advantage is that the ejectors do not require maintenance, periodical checks, safety precautions, special cleaning, spare parts, or adjustments during the lifetime of the sterilizer. Importantly, they do not contain moving parts nor require lubrication. The entire ejector assembly to include both the external and internal surfaces, such as the capillary gap, is fully within the steam contact area. Consequently, the ejector(s) are sterilized each and every sterilization cycle, as

*Continued on page 34.*

**ARE YOU RELYING ON  
SAFETY PRODUCTS  
THAT "SHOULD" WORK?**



**FIKE IS COMMITTED TO RELIABLE SAFETY SOLUTIONS THROUGH RESEARCH, NEW TECHNOLOGIES, AND EXTENSIVE TESTING.**

- Comprehensive selection of ASME, CE and 3-A rupture/bursting discs
- High performance explosion vents, specifically designed for sanitary applications
- Complete line of products for CIP/SIP applications
- Dedicated team of combustion engineers and pressure relief experts

**DON'T LEAVE THE SAFETY OF YOUR BUSINESS TO ANYTHING LESS THAN THE MOST RELIABLE, PROVEN PRODUCTS.**



VENTING



SUPPRESSION



RUPTURE DISCS



TESTING

**PROVEN PERFORMANCE, QUALITY  
AND RELIABILITY FOR OVER 60 YEARS**

**Fike®**

1-866-758-6004

WWW.FIKE.COM



Figure 4. Typical liquid load configuration.

with the chamber and associated piping. Actually, the sterilizing steam enters the pressure vessel through the ejector(s), meaning that they are intrinsically the hottest spot in the chamber and therefore, inevitably become sterile. Contrary to this design, traditional impellers with water sealing may become a focus area in the sterility qualification as cold spots within the chamber. FDA guidelines suggest that special attention should be given to the sterilization of those locations slowest to heat.<sup>1</sup> The sealing water flowing through the shaft penetration, although not intended for cooling, may induce colder spots into that particular area.

Another advantage of AMC is that it occupies minimal space within the chamber. Whereas a fan assembly can be rather bulky and require auxiliary stainless steel constructions around it, the AMC ejectors are stand-alone devices extruding only a couple of inches from the chamber ceiling. Further, the ejectors do not require any associated electric motors on the top of the sterilizer, thus minimizing the height and installation size of the unit. The noise levels of the entire sterilizer,

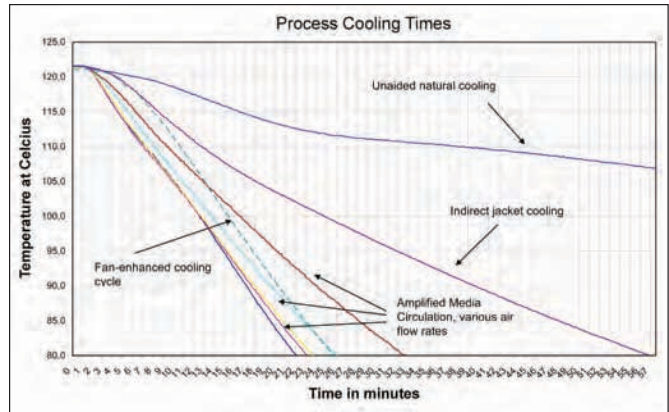

Figure 5. Comparison of various cooling methods.

including AMC devices have been independently verified not to exceed the OSHA or other safe criteria for operation.

Traditional terminal sterilization applications with fans have attempted to maximize laminar flow to optimize their use. This approach most often requires guides or baffles, thus restricting and redirecting the air flow and consuming chamber space. With AMC, the penetration is based on high air velocities which create the necessary turbulence within the chamber. During the cooling phase of a steam sterilization cycle, for instance, this turbulence prohibits stratification without the need for particularly guided flow patterns. Smooth and efficient cooling has been proven for representative full loads. Figure 6 illustrates the flow patterns during the cooling

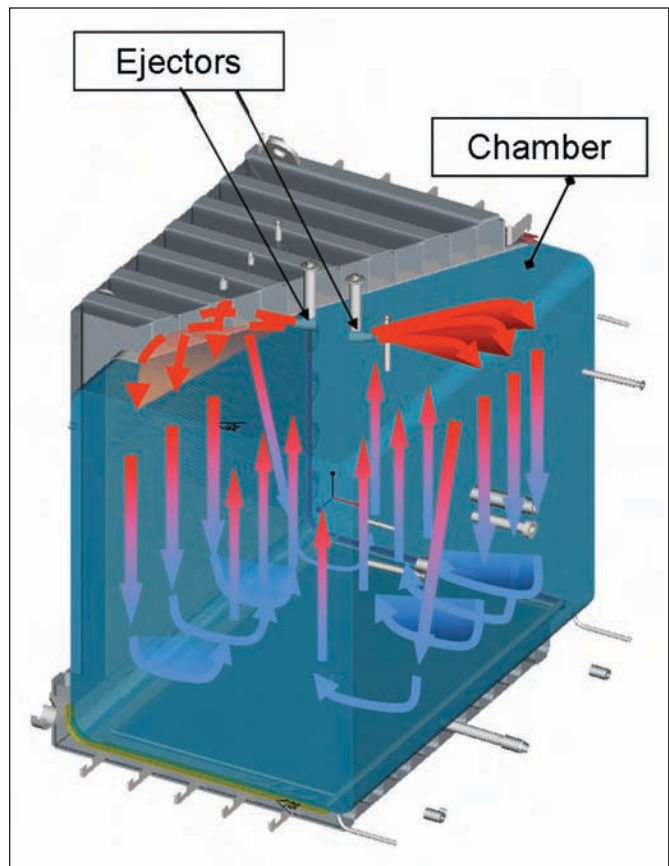

Figure 6. AMC flow patterns during cooling stage.

Date/Time	Temperature Probe Readings													
08-March-2007 09:06:00	121,20	121,10	121,10	121,20	121,10	121,20	121,20	120,90	121,20	121,10	121,10	121,10	121,10	121,50
08-March-2007 09:06:30	121,20	121,10	121,10	121,20	121,10	121,20	121,20	120,80	121,20	121,10	121,10	121,20	121,20	121,50
08-March-2007 09:07:00	121,20	121,10	121,10	121,20	121,10	121,20	121,20	120,80	121,20	121,10	121,10	121,20	121,20	121,50
08-March-2007 09:07:30	121,10	121,10	121,10	121,20	121,10	121,20	121,20	120,80	121,20	121,10	121,20	121,20	121,20	121,50
08-March-2007 09:08:00	121,20	121,10	121,10	121,20	121,20	121,20	121,20	120,90	121,20	121,10	121,20	121,20	121,20	121,50
08-March-2007 09:08:30	121,10	121,10	121,10	121,20	121,10	121,20	121,20	120,80	121,20	121,10	121,10	121,20	121,20	121,50

Figure 7. Typical temperature distributions with a full liquid load.

stage. Forced convection is induced by conveying the hot air rising through the load to the cold walls.

On the other hand, for some other stages of typical sterilization cycles (e.g., during the steam sterilization or holding phase) turbulent conditions should be avoided. The value of a pressure difference-driven device, such as AMC, is that when the pressure difference diminishes, the amplifying effect decreases in parallel. In this way, the flow rates come intrinsically down when the highest (or desired) pressures are approached. Subsequently, during the sterilization phase, the counter pressure in the chamber is at its highest, and the ejector flow rates are at their lowest and the delicate temperature balance can easily be maintained through this critical stage. Also, in the absence of shaft penetrations or cooling water for the shaft seal, cold spots or undesired convection of heat from the vessel are easier to avoid. Consequently typical, verified maximum distribution with a full load has been confirmed to be in the  $\pm 0.35^{\circ}\text{C}$  range (Figure 7) including the probe in the drain line. In an empty chamber, the distribution is normally within  $\pm 0.15^{\circ}\text{C}$  - Figure 8.

The same automatic adaptation applies to other phases of a typical sterilization cycle. During the post-sterilization cooling stage, higher flow rates are again desired (to enhance the forced convection and the heat transfer from the load), and the rates can be artificially boosted by allowing some air to escape from the vessel in a controlled manner. Mechanical agitators, such as fans, are typically running at the same speed throughout the cycle, and even though speed variation solutions that involve frequency drives can be implemented, the flow rates still do not adapt automatically to the process conditions as observed with the AMC devices. During the cooling phase, air is also exhausted from the vessel. The ASME pressure vessel codes state that the exhaust from the vessel must be piped to a safe place. Usually, the air exhaust from the chamber can be connected to the same pipeline, often leading to the outside of the building. If the safety device pipeline for some reason does not exist, the air could be vented directly into the room. In this case, the air flow rates must be taken

into account when designing the room ventilation. Often, the pressure differentials between various rooms are controlled accurately, and in cases like this, the air exhaust may not be allowed directly into the room, but must be piped either to the safety relief device line or to the drain line. In the latter case, the air exhaust should be segregated from the room with a water lock (siphon) to prevent the flow from disturbing the pressure differentials between controlled or clean rooms.

*Concludes on page 36.*

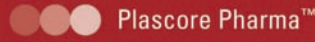





## Cleanroom Solutions

### Wall Systems and Walkable Ceilings

- Modular pharmaceutical wall and ceiling solutions.
- Demountable walls in progressive and nonprogressive options.
- Fully integrated doors and windows.
- Standard and custom finish options including painted, UPVC and stainless steel.

**Pharmaceutical  
Biotechnology  
Medical Research  
Life Sciences**





**PLASCORE®**

**Plascore, Inc.** 615 N. Fairview St., Zeeland, MI 49464  
 (800) 630-9257 sales@plascore.com www.plascore.com

Date/Time	Temperature Probe Readings												
13-May-2007 07:08:30	121,30	121,20	121,30	121,40	121,30	121,30	121,30	121,30	121,30	121,40	121,40	121,40	121,30
13-May-2007 07:09:00	121,30	121,20	121,20	121,30	121,30	121,30	121,30	121,30	121,30	121,40	121,30	121,40	121,30
13-May-2007 07:09:30	121,20	121,20	121,20	121,30	121,20	121,30	121,30	121,30	121,30	121,30	121,30	121,30	121,30
13-May-2007 07:10:00	121,30	121,20	121,20	121,30	121,20	121,30	121,30	121,30	121,30	121,30	121,30	121,30	121,30
13-May-2007 07:10:30	121,20	121,20	121,20	121,30	121,20	121,20	121,30	121,30	121,30	121,30	121,30	121,30	121,30

Figure 8. Typical temperature distributions with an empty chamber.

## Summary

Mechanical fans have been the traditional method for forced convection within steam sterilizer chambers. More modern alternatives to conventional fan, such as the AMC devices described in this article, can provide the same if not more efficient operation, but with less space within the chamber, with no moving parts to fail, requiring fewer utilities to operate and being virtually maintenance free. These advantages also can be provided to low temperature sterilization and other applications with similar technology.

## References

1. U.S. Department of Health and Human Services, Food and Drug Administration, Guidance for Industry: Sterile Drug Products Produced by Aseptic Processing – Current Good Manufacturing Practice, Rockville, Maryland, 2004.
2. Lewis, R.G., “Practical Guide to Autoclave Validation,” *Pharmaceutical Engineering*, July/August 2002, Vol. 22, No. 4, <http://www.ispe.org/pe>.
3. Nordhauser, F.M. and Olson, W.P., **Sterilization of Drugs and Devices**, Interpharm Press Inc., 1998, pp. 65-71.
4. Morrissey, R.F. and Phillips, G.B., **A Practical Guide for Manufacturers and Users of Health Care Products, Sterilization Technology**, 1993.

## About the Authors



**David A. Karle** is a Senior Product/Marketing Manager for Steris Corporation. He also is responsible for managing a team of professionals who work with pharmaceutical companies to develop sterilization cycles for their products. Karle started his career with AMSCO in 1974 as a senior research scientist.

He maintained that position for 11 years before joining the marketing group as a product manager for healthcare steam sterilizers. Since 1985, Karle has held various positions in product and marketing management of consumables and capital equipment in both healthcare and in the pharmaceutical businesses at AMSCO, which in 1996

became Steris Corporation. He can be contacted by telephone: +1-814-870-8578 or by email: [Dave\\_Karle@steris.com](mailto:Dave_Karle@steris.com).

Steris Corporation, 2424 W. 23rd St., Erie, Pennsylvania 16506 USA.



**Dr. Gerald McDonnell** has a BSc. (Hons.) in medical laboratory sciences from the University of Ulster and a PhD in microbial genetics from Trinity College Dublin. He is currently Vice President of Technical Affairs and Research for Steris Corporation, based at their European headquarters in Basingstoke, UK. McDonnell is widely published in the decontamination and sterilization area. His research interests include infection prevention, decontamination microbiology, emerging pathogens, and the mode of action/resistance to biocides. McDonnell is a member of the American Society of Microbiology, Society for Applied Microbiology, Hospital Infection Society, Council of Healthcare Advisors, European Biological Safety Association, PDA, and ISPE. He can be contacted by telephone: +44-1256-866560 or by email: [Gerry\\_McDonnell@steris.com](mailto:Gerry_McDonnell@steris.com).

Steris Limited, Steris House, Jays Close, Viabes, Basingstoke, Hampshire RG22 4AX, United Kingdom.



**Teppo Nurminen** has a Master of Science (Eng) in applied electronics and control techniques from the Helsinki University of Technology. He has held various managerial positions at Steris Finn-Aqua since 1994, and he is currently a Manager for Research and Development at the Tuusula facility, Finland. Prior to Finn-Aqua, he worked as an engineering consultant. He is the inventor or co-inventor in numerous international patents related to pharmaceutical water treatment, steam sterilization, and biohazardous effluent decontamination. He can be contacted by telephone: +358-9-2585227 or by email: [Teppo\\_Nurminen@steris.com](mailto:Teppo_Nurminen@steris.com).

Steris Finn-Aqua, Teollisuustie 2, 04300 Tuusula, Finland. 

[www.ISPE.org/strasbourgconference](http://www.ISPE.org/strasbourgconference)



## Managing Knowledge through Science and Risk Assessment

**28 September - 1 October 2009**

Palais de Congrès  
Strasbourg, France

### Seminars:

- Commissioning & Qualification: Practical Applications of Science and Risk-based Approaches to Validation
- Disposables and Containment Technology in Biomanufacturing: Managing Risk, Reducing Cost
- *GAMP*<sup>®</sup>5 Operational Aspects
- Barrier Isolation Forum, Innovation Updates and New Case Studies

- Investigational Medicinal Product (IP) Innovation in a Regulated Environment
- PQLI<sup>®</sup>: Global Realisation and Implementation of the ICH Quality Vision

### Training Courses:

- Basic Principles of Computerised System Compliance (*GAMP* 5)
- Cleaning Validation Principles

ISPE Strasbourg Conference Exhibition is sponsored by:  **INTERPHEX**2009<sup>™</sup>  
Conference & Exhibition

ENGINEERING PHARMACEUTICAL INNOVATION



Sponsorship and Table Top Exhibit Opportunities Available



**This article presents a case study on the area of utilities and facilities maintenance outsourcing within the pharmaceutical industry. This approach shows how the future for outsourcing is moving toward full ownership of utilities and facilities systems through long-term fixed contracts which have shown clear benefits for both parties involved.**

# Maintenance and Facilities Outsourcing Excellence – An Industry Case Study

by Padraig Liggan

## Introduction

**A**ccording to Jones,<sup>1</sup> it was found that in the early 1990s, as little as five percent of world class manufacturing organizations outsourced maintenance and facilities services. Within 10 years, by the end of the 1990s, this figure had risen to around 30%, particularly in the area of utility systems operations and maintenance. The outsourcing of maintenance at this time had started to reveal itself as a relatively new trend. Currently, in 2009, the number of world class manufacturing organizations who are outsourcing utilities and facilities operation and maintenance is estimated to be in excess of 40% and still growing.

The main reasons for outsourcing utilities and facilities maintenance are to allow the manufacturing company to focus on its core

activities of developing and producing product. Outsourcing the maintenance function can reduce costs by eliminating direct company headcount; enabling management to enforce change quickly, drive continuous improvement, and improve service levels. This is possible because the outsourcing company then becomes the 'customer' of this activity and is in a better position to demand the most for their money from subject experts.

The outsourcing of utility services within the pharmaceutical industry will in most cases include clean utility systems such as high purity water and steam systems (purified water, water for injection, clean steam) and cleanroom Heating Ventilation and Air Conditioning (HVAC). Facilities services will typically include building fabric maintenance, cleaning, and general building services administration. For the main-

Figure 1. The Wyeth Biopharma Campus at Grange Castle.



*Continued on page 40.*

# Solutions

## ANSWERS FOR ALL YOUR PROCESSING NEEDS

### In the Exhibit Hall:

- **Over 300 Exhibitors** - Leading manufacturers of process equipment, systems and technology for fluids, solids, and plant services.
- **NEW Technology Workshops** - An interactive opportunity to discuss specific solutions with participating exhibitors.

### In the Classroom:

- **NEW AIChE Day** – One-day Conference developed by AIChE addresses proven solutions to adapt to your projects.
- **Chemical Engineering Magazine Educational Conference** – Two-day program presenting practical seminars for more efficient process operations.
- **Nano & Green Technology Symposium** – Two-day Symposium and Workshop on the opportunities that currently exist to incorporate nanotechnology into your operations - developed by iRAP.

### OnLine:

- **NEW Matching Service** connects you with the exhibitors that have the right products and solutions you need.

**More to see, do and learn at the  
process industries #1 event.**

Free Show Registration and Information:

[www.chemshow.com](http://www.chemshow.com)



*The New*  
**CHEMSHOW**  
Processing Solutions  
for a Changing Marketplace

**November 17-19, 2009 | Javits Convention Center • New York City**

Produced and managed by:

INTERNATIONAL EXPOSITION CO.

Telephone: 203-221-9232 • E-mail: [info@chemshow.com](mailto:info@chemshow.com)

Endorsing Associations:

AICHE

FCI  
Fluid Controls Institute, Inc.

FLUID SEALING  
ASSOCIATION FSA

ICAc

VMA

tenance outsource provider, customer satisfaction is a primary area of focus, which is a motivation for the expert service provider to deliver a best in class, value for money service, not necessarily felt as deeply as in-house staff. Outsourcing partners are generally non-unionized and so the risks of strike or halts to manufacturing as a result are extremely low.

By setting out clear objectives and outsourcing to an experienced company, great results can be achieved. Outsourcing should not be mistaken with relinquishing of overall responsibilities. For example, in the pharmaceutical industry, legal aspects such as regulatory compliance for drug manufacturing must be maintained and closely monitored and the outsourcing company must provide safe systems of work. Outsourcing of utilities (particularly clean utilities) and facilities should be a risk-based approach where over time, the contract company becomes more empowered through satisfaction by the client company that high quality services can be consistently delivered. The company also should employ people to monitor performance of the outsourced contract and to develop service level agreements. All the major manufacturing companies in Ireland have adopted various degrees of maintenance and facilities outsourcing as part of their business strategy. This has paved the way for a new emerging industrial services business sector in Ireland: outsourcing services, such as facilities, maintenance, and security. Competition in these areas is healthy, which of course encourages the industry-wide provision of better value for money. This is allowing Irish companies to build expertise in these areas by being able to support large multinational companies who wish to set up in Ireland. This ability of these service companies can be a positive factor in the decision-making process of a company potentially choosing Ireland as a location.

## Building Outsourcing Excellence

In 2001, it was announced that pharmaceutical giant Wyeth was to invest €1.8 billion (\$1.8 billion) in a state of the art biopharmaceutical plant at Grange Castle, West Dublin. Later that year, the construction of one the world's largest biopharmaceutical plants began at Grange Castle - *Figure 1*.

In 2002, maintenance outsourcing began with the externalization of the utilities and facilities maintenance organization in order to operate plant utilities and to setup maintenance programs for the site. Although we don't often see plants of this size being constructed, this is the best time to form an alliance partnership with the maintenance outsourcing company, working together from the start, regardless of plant size.

Since 2002 to the present, Wyeth and its outsourcing strategies have evolved to form one of the best examples of outsourcing excellence in Ireland today. There are a number of key areas that have contributed to this success.

## Utilities and Facilities Outsourcing: A Self-Managed Service

Wyeth expects and encourages the outsourcing companies to have a high degree of ownership when it comes to operating and maintaining utility/facilities systems. In each manufacturing area, the contract is overseen by one Wyeth cost center owner

who monitors contract performance and contract spend. This structure is beneficial to Wyeth and they don't need to get involved in the day to day running of the plant. Through the cost center owner, Wyeth management has a good visibility of the performance of the contract and the areas that may need to be addressed. Performance is measured through areas, such as availability, planned work vs. actual, safety and regulatory requirements. For clean utility systems (which are qualified systems and feed manufacturing areas directly), high level compliance is ensured through Wyeth subject matter experts and the Quality Assurance group in each area. Wyeth has overall responsibility for the safety of their products and this structure needs to exist. Figure 2 details the type of organizational structure that has been set up for the outsourcing of utility systems in manufacturing areas.

The outsourced teams interact with local quality groups and manufacturing area owners on a daily basis as would occur in any pharmaceutical organization. Overall, the contract is overseen by a client operations manager along with client quality support. One of the key advantages of this structure is that the outsourced company can be measured directly against the equipment/system uptime that is being provided; this is because they own every activity within the maintenance organization. In some outsourcing situations, only certain tasks are contracted (also known in industry as "body shopping"). In this scenario, it can be difficult for the company to achieve full accountability from the contractor for systems performance. Where the outsourced company has a high degree of ownership of systems, continuous improvement is a natural evolution, and this should be supported and encouraged by the client company.

A service level agreement sets out clear expectations and tasks to be performed by the outsourcing partner. The manufacturing companies' measurement of the contract is important; company's can't manage what they don't measure, and this is where Key Performance Indicators (KPIs) have a part to play. The KPIs can be structured in terms of plant availability, scheduled work completion, and safety and compliance with specific targets, among others. Penalty clauses can be employed for performance targets that are not met, this approach creates a mutual gain "win-win" (i.e., both share the risks and rewards) environment in which all parties see the benefit of high performance.

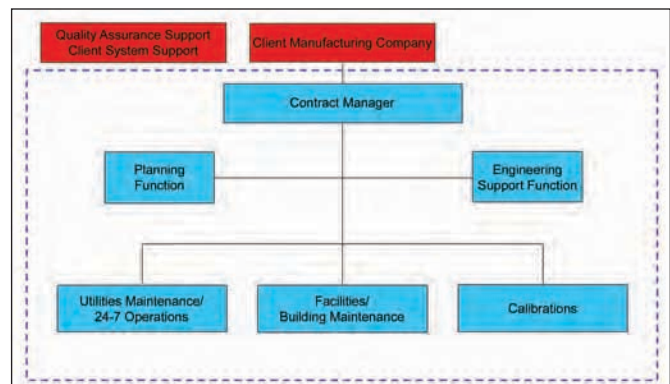

Figure 2. Typical outsourcing organization chart for utilities/facilities.

Within the outsourcing structure, the internal site training systems should be adopted by the contract company for areas such as procedural, GMP, and safety compliance. There should be an expectation that the outsourced company will continually develop their own employees by providing additional technical/equipment specific training.

By creating the outsourced maintenance function as a separate entity, it means that whatever is happening in production, good or bad, the utilities and facilities equipment/systems performance is not compromised. In cases where the maintenance function is in-house, the company departments have tendencies to abandon the maintenance function temporarily in order to sort out problems in production, which can potentially lead to system performance and regulatory compliance suffering due to lack of focus.

### An 'Alliance Partner' not 'Contractor'

Utilities and facilities outsourcing plays an important role in the day-to-day operation of the Wyeth plant in Grange Castle and for this reason, high recognition is given to the outsourced company by providing them with internal facilities such as training, computer network access, and opportunities to become involved in site business initiatives. Instead of being "housed away in the back-yard," the outsourced company operates alongside Wyeth on a daily basis.

The term "contractor" is very rarely used, rather an "Alliance Partner" with Wyeth. In many plants, the outsourced

company is often referred to as "those maintenance people" and this stigma creates an "us versus them" relationship, which can inhibit improvement, hinder trust, and have a negative effect on overall plant performance.

All of the above approaches by Wyeth create a true partnership between the client and the outsourced partner, and the relationship is based on mutual trust and mutual gains.

### Building for the Future

At present in Irish industry, companies are in the process of negotiating long-term contracts with utilities and facilities service companies who take over full ownership of the plant. This type of approach can provide for a "Black Box" service, which further enables the client company to reduce overall costs and focus on their core business. This sort of contract arrangement is set to become the future for outsourcing of utilities and facilities.

Again this is a win-win situation for both parties; on one hand, the manufacturing company has an ability to set long term fixed budget costs for each year in return for the supply of utilities and facilities services. For the outsourced company, an operational profit is made over the term of the contract, and investment can be made for the long term development of its people without the fear of losing them through loss of short term contracts. Typical KPI measurements are as follows:

*Concludes on page 42.*

## Push a button and walk away



## Automate your TOC analysis



Be Right™

## Anatel PAT700: The first TOC analyzer for on-line release

- Simplify validation and reduce operator intervention with OASIS™ Onboard Automated Standards Introduction System
- Provide peace of mind, superior reliability and uptime with UV Detect™ and advanced diagnostics
- PAT design for compliance in the most demanding regulatory environments

**Call or email to schedule your demonstration:**

HACH COMPANY World Headquarters  
Toll Free: 800-866-7889  
Fax: 970-461-3914  
Email: [orders@hach.com](mailto:orders@hach.com)  
[www.hach.com](http://www.hach.com)

- Utility Systems Plant availability (expectations >99.5%)
- Quality Compliance (CAPA Investigations timely closure, maintenance scheduled Vs complete)
- Safety (number of incidents, no lost time injury)
- Innovations/plant efficiencies/energy savings (bonus payment provisions in place)
- Facilities response times and timely closure of logged items

With a strong outsourcing partnership in place, it is estimated that the pharmaceutical company can expect to make savings in excess 20% in comparison with the alternative internal structure. With a long term fixed price contract, it is within the outsourced company's own initiative to continuously improve in order to gain a higher profit margin on best efficiency and performance of high availability utilities being sold back to the client.

## Design, Finance, Operate, and Maintain

During the construction of a new plant, another popular option is to completely outsource the plant core utilities. Some outsourcing companies can design, build, finance, and operate and maintain the central utilities plant, which can include steam, electricity, air, water, etc. With this arrangement the client company can focus on getting its manufacturing facilities up and running and be supplied with plant utilities which can be purchased at unit cost. At an operating level, the outsource partner, in close cooperation with the client, can offer ongoing savings and efficiencies in the area of energy use and consumption.

This package often includes a Combined Heat and Power (CHP) plant, also known as co-generation CHP, which is the simultaneous generation of usable heat and power (electricity) in a single process.

An overview of a CHP plant is shown in Figure 3; CHP plants are over twice as efficient as a traditional power plant. The CHP plants are built on the factory premises, electricity is sold back to both the factory and the national grid, and heat generated by the plant is then re-used in the factory.

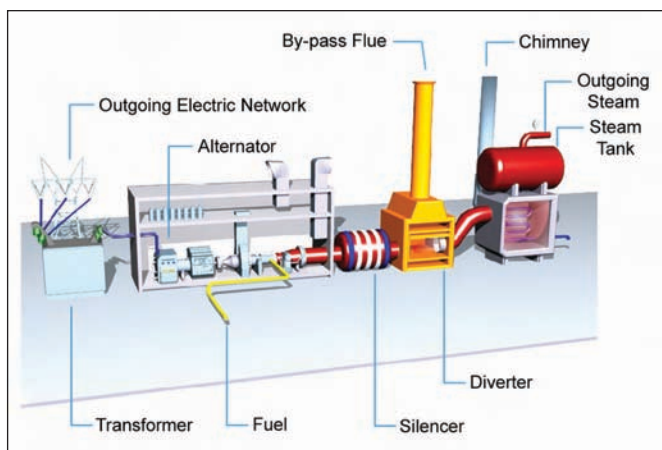

Figure 3. CHP power generation.

In 2009, a CHP is set to be constructed at the Wyeth Grange Castle plant. This project is an example of the design, build, finance, and operate/maintain model mentioned above.

## Summary and Conclusion

Following research and from the author's own experience, the area of maintenance outsourcing has been identified as a major part of modern industry. As discussed earlier, the main driver for manufacturing companies to outsource maintenance is to reduce costs and to enable them to focus on the core activity of making product, while gaining best service performance. However, this is only the baseline of possibilities – so much more can be achieved by approaching outsourcing correctly, leading to a high degree of ownership by the outsourcing partner, continuous improvement, and a win-win culture which promotes open/honest communication. The future for outsourcing is moving toward full ownership of utility systems through long-term fixed contracts that have shown clear benefits for both parties involved.

## References

1. Jones, K.E., "10 Key Indicators of Maintenance Performance," *Information Service Centre for Energy Industry*, 1999.
2. Welch, S., "A Plan for Maintenance Success," *Advanced Technology Services*, 2002.
3. Martin, H.H., "Contracting out Maintenance and a Plan for Future Research," *Journal of Quality in Maintenance Engineering*, 1997, Vol. 3, No. 2, pp. 1355 -2511.
4. Durand, A., "The Benefits of Outsourcing Maintenance," *Caribbean Business (Industrial Maintenance Supplement)*, 2003.
5. Ireland, B., "Outsourcing Options," *Electrical Contractors & Maintenance (EC&M) Magazine*, 2006.
6. Liggan, P., "The Research and Implementation of Maintenance Excellence on Clean Utility Systems in the Pharmaceutical Industry," Dublin Institute of Technology, 2008.
7. <http://www.dalkia.ie> – Combined Heat and Power Plants.

## About the Author



**Pdraig Liggan, MEng, BSc (H)**, has worked in maintenance engineering within the pharmaceutical and dairy industries for the past decade. He is currently employed with the energy and facilities management engineering company, Dalkia Ireland Ltd., where since 2003, he has been heavily involved in setting up start-up maintenance programs

at the new Wyeth, Grange Castle plant. The Wyeth plant at Grange Castle is currently one of the largest integrated Biopharmaceutical campus' in the world and is still undergoing further expansion. He can be contacted by telephone: +353-1-4648959 or by email: [ligganp@wyeth.com](mailto:ligganp@wyeth.com).

Dalkia Ireland Ltd., 145 Lakeview Drive, Airside Business Park, Swords, Co. Dublin, Eire, Ireland.



# 2010 Facility of the Year Awards



**Bristol-Myers Squibb**  
was a winner from  
the New Jersey Chapter.



was a winner from Germany.

**Genentech**  
was a winner from the Greater  
Los Angeles Chapter.



was a winner from China.

Will the next Facility of the Year  
Award Winner come from your  
chapter or region?

The Facility of the Year Awards program celebrates state-of-the-art pharmaceutical manufacturing projects utilizing innovative technologies to improve the quality of projects and to reduce the cost of producing high-quality medicines. Companies from 21 countries have submitted and won...the next award-winning company could be a part of your local community.

Submit an entry to the 2010 Facility of the Year Awards program and your firm may win the coveted Facility of the Year Award! Don't let your company pass up this outstanding opportunity to showcase its new or renovated facility. The program and each of the Facility of the Year Award winners will receive high-profile attention and media coverage from ISPE, INTERPHEX™, and *Pharmaceutical Processing* magazine.

**Deadline for Submissions: 2 November 2009**

For additional information about the Awards and submission procedures, visit  
[www.facilityoftheyear.org](http://www.facilityoftheyear.org).



ENGINEERING  
PHARMACEUTICAL  
INNOVATION



[www.facilityoftheyear.org](http://www.facilityoftheyear.org)

A veteran quality executive, Sharon Bleach discusses her philosophy on quality, her experience as previous chair of ISPE's International Leadership Forum, and insight into AstraZeneca's strategic approach to significant changes in the industry.

# PHARMACEUTICAL ENGINEERING Interviews

## Sharon Bleach, Vice President, Global Quality, Operations, AstraZeneca

by Rochelle Runas, ISPE Technical Writer



**Sharon Bleach** followed her degree in biophysics from Sussex University with a role in research at the Max Planck Institute in Berlin, then West Germany.

On her return to the UK, Bleach joined Wellcome's biotechnology R&D organization at Beckenham and then moved into developing deep cell culture plants in the UK, Spain, Canada, Japan, and the US. During this time, she also studied and earned her MBA from Warwick University.

Moving from R&D to Quality, Bleach led activities in a number of project and line management roles across both biotechnology and small molecule areas.

After the GlaxoWellcome merger, Bleach held quality roles covering UK and European sites. Following the merger of GlaxoWellcome and SmithKline Beecham, she became Head of Quality for European sites in eight countries, later moving on to quality associated with new product introduction in Europe, US, and Puerto Rico.

Before joining AstraZeneca in July 2008, she completed 28 years with GSK as Head of Quality Strategy, introducing a revised Quality Management System, leading Quality Training and Development and involvement in External Relations.

Bleach believes that quality is about keeping things simple, getting them right the first time, and working with motivated people who do the right things.

**Q** What are your primary responsibilities in your current position as VP, Global Quality, Operations, AstraZeneca?

**A** As a member of the leadership team for Operations, which is the manufacturing and supply operation, I am responsible for the strategy and delivery of quality activities across Operations. I have the additional role of overseeing all GxP activities throughout AstraZeneca.

**Q** What experiences and training best prepared you for your current position?

**A** Life itself! I've been very fortunate and had many different roles in my career so I have a broad experience base. I've done both site-based and corporate roles, as well as having R&D and quality experience. I've also been extremely fortunate in working with many different nationalities and cultures through the course of my career. That has provided a tremendous learning experience and opportunity to understand different things about the different cultures and countries, which is very useful in a leadership role such as this.

**Q** What are the major challenges faced by a senior quality executive in a pharmaceutical organization?

**A** I guess there's always the "not enough time in the day," which is probably typical of many senior roles in many industries. I think part of it is that regulators look on the quality organization as almost a surrogate for them in the industry, yet you're operating within a company, understanding the company perspectives and priorities. Really it's about how do you balance what regulators are expecting with the

company's need to be successful and, in doing all that, making sure patients get the right product when and where they need it.

**Q** Please elaborate on your philosophy, "Quality is about keeping things simple, getting them right first time, and working with motivated people who do the right things."

**A** Regulations are complex, whether you take one country, such as the US and the FDA regulations there, or whether it's Europe with the European Medicines Agency (EMA) and authorities in each member state, or whether it's Japan, Canada, Australia, etc. One of the biggest challenges is how you integrate those different requirements and how you make sure you're in line with all of those different requirements.

I also think you have to have people who want to come to work, because if they aren't enjoying what they're doing, if they don't think it's important, if they don't recognize the value that patients get from what we're doing in this industry, then you don't have the differentiator that people will keep focused. So, for me, you've got to motivate people to want to improve, to want to constantly be looking for the next idea, the good way of doing things, and how you can simplify. And the more we simplify the more of a chance we've got to get it right.

**Q** Do you think that industry and regulators are understanding that keeping things simple is the best way and is that reflected in how they're revising and coming up with regulations?

**A** I think the dialogue is much more about continuous improvement now and I don't think that people think that continuous improvement necessarily means adding complexity. Whether or not as an industry – taking regulators and suppliers together – we have focused enough on simplicity and simplification: No, I think there's more we can do there.

**Q** You've presented on ICH Q10 and been involved in the ISPE and PIC/S joint conference focusing on ICH guide-

lines in 2007, so I'm going to assume that the Quality Management System at AstraZeneca is based on Q10. Am I correct in that assumption?

**A** That's correct! I've only been at AstraZeneca since last July, but the Quality Management System is linked to Q10. However, we're also doing work on our quality system to put it into a new format and to emphasize the process thinking across the company and

around how we do that. Essentially, I think that's in line with many different companies in the industry.

**Q** Do you feel ICH guidelines are becoming part of the culture within the quality organizations of pharmaceutical companies?

**A** Yes, I think so. I think the potential benefits from ICH Q8, Q9, and Q10 are a significant opportunity for

*Continued on page 46.*

## Sterile Clean Steam Sampling



**GEMÜ BioStar®** Steam Sampler, the innovative automated sampling system for the monitoring of pure steam quality

- **Sterile from the steam pipe to the laboratory**  
Sterilization prior to sampling, sterilized sample container, sterile sample transport
- **Automated, programmable and safe**  
Hands-off auto sampling method eliminates potential contamination of the sample and minimizes risk of injury to operating personnel
- **Consistent, reliable and time saving**  
Automation of the activity provides consistency and repeatability while reducing the time required to complete the sampling by plant personnel
- **Easy to install - easy to operate**  
Simplified connections, easy plug and start, air-cooled, mobile or fixed installation, repeatable and programmed process

**GEMÜ®**

GEMÜ Gebr. Müller Apparatebau GmbH & Co. KG · Fritz-Müller-Str. 6-8 · D-74653 Ingelfingen  
Phone +49(0)7940/123-0 · Telefax +49(0)7940/123-224 · info@gemue.de · www.gemue.de



industry and regulators. So, it would be shortsighted, perhaps, of companies to ignore the opportunities that are there. You can either say, "Well, we'll start by working on these things now and it may not be perfect, but we'll improve as we go on," or you can say, "We'll hang back and wait and see how it works." We've decided we're going to be in the forefront of this because we think there are some significant benefits and I know there are a number of companies that are doing exactly the same thing.

**Q** Your career has encompassed positions in R&D and quality. Did your experiences in R&D help you bring different perspectives to positions you've held in Quality? What are those perspectives?

**A** When you're in R&D you learn very clearly: You only ever make one change at a time in an experiment otherwise you don't know what impact it's had. And that lesson, I think, has stood me in good stead when going through a lot of quality changes and initiatives. If you make multiple changes at the same time, you have no idea which ones have any impact.

I think in general, it is about understanding the whole product development lifecycle. Understanding the early stages and how you work some of those things through is helpful in terms of looking at the lifecycle management of products and what you need to think about at different stages.

I also think it's valuable not to think of there being some big brick or glass wall between R&D and manufacturing organizations, because the skill sets are very transferable between the different areas. I think it's great to be able to encourage people to move between different parts of a business to see those different perspectives.

**Q** What was your experience like as previous Chair of ISPE's International Leadership Forum (ILF)?

**A** I thought it was a tremendous opportunity and really enjoyed doing it. It was great to have the opportunity to actively shape where ILF went for a period. We set up some different work

teams, which enabled us to have some energy from ILF Members focused on the key topics that were of concern to industry and to regulators.

**Q** What are some of those key topics?

**A** One of our major pieces of work is around supply chain security and teams looking at what industry can do to more actively engage with supply chain security initiatives that regulators are highlighting they're particularly concerned about. And obviously it came a lot from the discussion around contaminated milk, or melanin, or the Heparin situation.

We had a very good discussion about 18 months ago with some of the regulators who basically said, "Look, this is our top priority." It was really satisfying to be able to say to the regulators, "Actually, the ILF has already discussed this and we've got a piece of work we are going to be undertaking that you're welcome to be part of and provide us with input and we'll have dialogue with you about what we're doing." The next step will be during this year's Washington Conference with a seminar on Supply Chain Integrity and Anti-Counterfeiting.

**Q** In your opinion, what have been the significant changes in the industry in the past decade and what are the challenges for the future?

**A** One of the big challenges over the past decade has been that the industry as a whole seems to have moved from being perceived as adding value and doing the right thing for patients and people around the world, to being an industry that is not valued in the same way at all. That image and reputation shift and damage is really unfortunate because the majority of people in this industry are here to do the right thing for patients and to make a positive difference to peoples' lives.

The other thing is the consolidation that's going on in the industry at the moment. Companies across the industry understand that the future is going to be very different, and that we all have to approach our response to

these changes in the best way we can. At AZ we are seeking more partnerships and collaborations, as well as driving down our operating costs as much as we can without compromising our quality focus, to ensure our approach to drug development is cost effective, as well as being sensitive to the unmet needs of patients.

**Q** In light of these challenging economic times, some predict that pharmaceutical companies will build themselves horizontally rather than vertically with outsourcing playing a bigger role in that change. In your experience with different companies and certainly now, are you seeing this happen?

**A** Yes. We're actively outsourcing some activities, where the activity is not core and we think another organization can do it in a more effective way, and actively consolidating in house for others that we see as a core strength for us. The key is to maintain great quality and a focus on delivering great medicines for patients.

**Q** In what ways do you believe a global organization such as ISPE can assist regulators, pharmaceutical companies, and individuals in the international arena?

**A** I think one of the greatest opportunities for ISPE is that it provides a whole series of different forums for discussion between regulators and industry and individuals as peers. You can have very good dialogue about the challenges that face the industry either at a high level and global picture, or you can take it down to an extremely detailed technical level and make sure that we've got a common, good understanding of good ways of addressing a technical issue. And it's that breadth in terms of the range of people who are involved, the range of issues, and the levels of the dialogue that can take place.

**Q** Coming from a biotechnology background, what technological and operational breakthroughs do you anticipate within the next five years?

**A** First, I'd say that my direct biotech experience was quite a long time ago. I think one of the things about biotech is that it's been a long time coming and we're still not quite there yet. We'll see more biotech products coming through as there is a greater push for more complex medicines that respond to those areas where there is unmet medical need. But that will be balanced by the pressure on healthcare budgets and the cost of developing these biological medicines, which are more complex and therefore cost more to deliver.

**Q** What has been your most fulfilling role so far in your career?

**A** Well of course the one I'm in now, because it really brings together a lot of the points I learned, the skills and experiences that I've picked up along the way. It's great to be able to work in a global role with many different countries and different groups internally. Also, I find it really good to be able to work externally. I think it's a

really good challenge for the company to make sure that you don't just have an internal perspective. You need to keep an eye on what's going on in the external environment and challenge yourself all the time with that. This role is great and I'm thoroughly enjoying it.

**Q** What kind of career advice can you offer to our readers who are pursuing careers in quality?

**A** I think quality provides a great grounding and a great way into the industry. There are technical skills that people can learn which they can apply to multiple other roles in the industry. The thinking in a quality group is a good education and helpful in terms of looking at different perspectives.

I also think there should be a very dynamic flow with people coming through quality as part of a career or part of an education process and into other roles. So it's a two way flow in and out of quality. Some will be there all their careers, some will spend only a short while there; both are perfectly valid.

I think that quality organization has a real opportunity always to shape how a business is working, to add value to the business. I think in the past people used to see quality, at best as a necessary cost, and at worst as an unnecessary encumbrance. Today, it is considered much more of an opportunity to add value to product flow and to corporate reputation.

**Q** What kind of activities do you enjoy in your free time?

**A** I love spending time with family and friends. I love to garden, to sit and read, and to have a good glass of wine.

I also enjoy traveling with my family; we are planning a trip to Jordan later in the year to see Petra, the Dead Sea, and Wadi Rum. I have to get really fit for that I'm told, because my daughter has grand plans about climbing up huge numbers of steps in Petra to get good views! 

## IMA, the expert in containment process



all O.E.B. categories.

**MORE THAN 60 DIFFERENT INSTALLATIONS WORLDWIDE** for dispensing, handling, granulating, tableting, capsule filling and coating of category IV and V products, both for production and R&D applications.

- Customized solutions.
- Isolated processing areas on all machines due to special sealing systems.
- Isolation at product loading and exit due to isolators and high containment valves.
- Possibility to install in-line indirect methods to control the high containment manufacturing process.
- Special solutions for the treatment of air exhausted from the processing area and dust extracted from the machines during production.
- Clean In Place systems.

**IMA ACTIVE Division**  
mktg.soliddose@ima.it • www.ima.it

**IMA NORTH AMERICA, INC.**  
sales@imausa.net • www.imanorthamerica.com

**IMA**  **ACTIVE**  
Solid Dose Solutions

HANDLING • GRANULATION • TABLETING • CAPSULE FILLING AND BANDING • WEIGHT CHECKING • COATING • WASHING

This article presents the outcome of a series of workshops on the effects of rouging in pharmaceutical water and steam systems.

## Rouge in Pharmaceutical Water and Steam Systems

by ISPE Critical Utilities D/A/CH COP

### Introduction

The ISPE Critical Utilities D/A/CH COP held a series of workshops on pharmaceutical water and steam. The discussions focused on three aspects of rouge, including:

- Choice of materials, quality control
- Engineering, system design
- Service and maintenance

Fifty experts participated in the workshops with a range of experience in various fields, including OEM, engineering, material production, instrument manufacturing, consulting, QC, and pharmaceutical manufacturing.

### Choice of Materials, QC-Service System Startup

The desired condition for new systems (zero or initial-state) should be well defined.

- Sufficiently detailed specifications should be available for all components (material, surface roughness, and tolerances) and these should be tested during the qualification phase. The thermal and chemical resistance also should be checked. Furthermore, special care should be taken regarding the cleanliness of all components from the time of delivery onward.
- If possible (cost feasibility), the materials for pipes, fittings, and valves should be the same to avoid different behavior (welding).

### Definition of "Treatment"

At the end of the installation phase, the entire assembly must be dry.

The following methods are considered treatments:

- Removal of any installation debris, i.e., using compressed air, degreasing, etc.

- Pickling, passivation, rinsing

Each method should be executed, tested, and documented in accordance with a Standard Operating Procedure (SOP). The SOP can be created with the support of the expert/qualified company. The responsibility for the execution should be defined in the SOP.

### Methods

#### Compressed air

- Removal of large debris
- Check for blockage

#### Rinsing

- Rinsing is used to remove:
  - Loose debris or water soluble substances
  - Detergents, etc.
- Rinse after each treatment step.
- The water quality for each rinse step should be defined individually. Purified Water (PW) is usually sufficient.
- The PW should have a pH of five to seven at the end of the rinsing cycle.

#### Degreasing with Alkaline Detergents

- Removal of debris
- Wash out fatty or oily substances

#### Chemical Cleaning/Pickling

- The makeup of the chemical solution should be suitable for the surface roughness of the system (qualified SOP).
- Removal of contaminants (nonalloyed ferrous components, shavings (alloy and nonalloy), construction dust, discoloration, etc.)
- In special cases, such as surface damage, removal by chemical reaction (erosive)
- Electro polished systems, if pickled, are pickled without material removal (see following comments).

#### "Pickling:"

Pickling (cleaning) with weak acids (citric acid,

phosphoric acid) dissolve just surface contamination without damaging the material. The passive layer remains intact. Erosive pickling only takes place using reducing acids or acid mixtures, such as nitric acid or nitric and hydrofluoric acid mixtures and results in the chemical removal of the passive layer. This is usually not necessary for the pharmaceutical industry.

In general, the comments regarding erosive and non-erosive pickling are necessary because pickling always removes something. A film or discoloring could be seen, but are removed during pickling, revealing the layer below.

## Passivation

- The passive layer is always present in a neutral, water based system at ambient temperatures, even at atmospheric exposure with air (oxygen environments, chemical equilibrium).
- The stability and homogeneity of the passive layer is dependent on the redox potential.
  - An oxygen supply is necessary for an optimal redox potential.
  - A low pH is unfavorable. Since CO<sub>2</sub> reduces the pH value, its concentration should be minimized.

## Developing the Passive Layer

- The presence of O<sub>2</sub> or other oxidizing agents, such as ozone, supports the development of the passive layer.
- The passive layer can be artificially developed with chemical treatment. The results of such a treatment are only temporary and not permanent. In time, the system will return to the equilibrium state dictated by the redox system.

## Testing the Passive Layer (Thickness)

- The passive layer doesn't normally need to be tested since it is naturally present.
- There is no regulatory requirement to test the passive layer.
- The thickness of the passive layer is dependant on the surrounding conditions; therefore, varies according to the conditions in the pipe (for example, if the pipe is filled with liquid or air). Due to this variability, testing the thickness of the passive layer only gives information on the state of the layer at the time of the testing.
- Possible measuring methods can be conducted by qualified experts. Laboratory tests (destructive testing), such as X-ray photoelectron spectroscopy, are time consuming and expensive.
- Non-destructive online measurements, which characterize the condition of the material, have been proven in the chemical industry. These are indirect measurements, using sensors made of the same material, which are evaluated using complex algorithms.

## Final Rinse

- With *water for injection, highly purified water, or purified water* the minimum required water quality should be defined (potential cost savings). This quality should be at least equal to the operating medium. For instance, if WFI

is required for the production, then the final rinse should be conducted using WFI.

## Handover Criteria

- The success of the rinse should be proven using suitable acceptance criteria, for instance, conductivity and TOC are frequently used. The tolerance range should correspond to the same predefined range as the rinsing water.
- Visual control at accessible points or with video endoscope can be used to ensure that no installation debris (non-suspended particles) has been left behind.

## Measures for Existing Installations

The system components for existing installations should have documented specifications. If this isn't the case, then the current state of the system components should be documented through a detailed system analysis. At least the following aspects should be considered as adapted treatment methods or processes may be required:

- Material qualities
  - Corrosion resistance is dependant on these characteristics. Therefore, if rouging is corrosion, it follows that the material quality influences the rouging tendency.
- Surface condition (surface roughness, visual evaluation of the surface condition, type and extent of the rouging)

*Continued on page 50.*

[www.ISPE.org/innovationshowcase](http://www.ISPE.org/innovationshowcase)

Register today!

## ISPE Facility of the Year: Innovation Showcase

**2-3 November**

Ulm, Germany

Learn about the latest state-of-the-art developments being implemented by manufacturers in the region.

- Seminar on innovation in pharmaceutical engineering and manufacturing
- Case studies on innovation presented by recent Facility of the Year Awards winners
- Background on projects
- Q&A sessions
- Networking reception
- Site visits to award-winning sites

ENGINEERING PHARMACEUTICAL INNOVATION



Sponsorship and Table Top Exhibit Opportunities Available

- Safety aspects, such as solid connections rather than flexible tubing
- Disposal of treatment and rinsing solutions

System analysis and evaluation should regularly take place using existing monitoring results.

## *Definition of Treatment*

If the system analysis shows a need to take action, suitable treatment methods from the list above should be used.

## **Measures for Derouging**

### *De-rouging of Existing Installations*

The derouging method should be conducted, tested, and documented in accordance with a Standard Operating Procedure (SOP). If necessary, existing warranty conditions should be taken into consideration.

- The SOP can be developed with qualified experts.
- The responsibility for the execution should be decided in advance.

*The recipe* should be based on the following:

- Current state (see above)
- Suitability tests (effectiveness) should influence the choice of the process.

*The frequency* of derouging should be based on the following criteria:

- In accordance with monitoring results (months, years)
- In accordance with experience and knowledge of the installation
- Dependent on the state

*Testing* and documentation can be assigned to the contracting company.

- Visual inspection in accordance with agreed acceptance criteria (colors, film, etc.)
- Wipe test
- Photos, etc.

## **Choice of Materials and Processing/Machining**

The choice of materials influences the formation of rouging.

### **Plastics**

#### Pros:

- No rouging because it is a nonmetallic material

#### Cons:

- Thermal deformation from variance in temperature (hot operation or sanitization)
- New design of piping supports (high expansion value)
- Aging stability (hot sanitizations)
- Not always feasible for hot systems. Pressure and vacuum

tolerances must be observed, regarding the piping connections.

- Mix of materials – for instance, a stainless steel tank, piping in PVDF. A rouging layer can be transported onto the plastic surfaces.
- The chemical tolerance of PVDF is limited to a maximum of pH 12 (relevant for treatment chemicals).

### **Metal Alloys**

The austenitic stainless steels used most frequently in the pharmaceutical industry are 1.4404/1.4435 (316L), 1.4571 (316Ti).

#### Pros:

- They can be used for cold and hot media. Almost all components are available in these materials.

#### Cons:

- Stainless steel is susceptible to rouging.

#### *Specific characteristics of individual alloys:*

- 1.4404 – somewhat less Mo (0.5%), slightly reduced corrosion resistance in hot systems. Good availability (tubing, fittings, instruments, valves, etc.)
- 1.4435 – limited availability of fittings and instruments. Expensive material. Also susceptible to rouging.

Other alloys also are possible; however, they may be more difficult to procure and are significantly more expensive.

1.4539, 1.4462 (Ferritic-Austenitic Duplexsteel), Ni-Basic-Alloy, Alloy 33 (high content of chromium), Titanium.

#### Pros:

- These special materials could be more resistance to rouging; however, this has not been proven yet.
- 1.4462 is resistant to rouging for a wide redox range in pure water systems, but doesn't solve all problems.
- Optimizing the passive layer through higher chromium content. The Alloy 33 with 33% Cr shows a chromium content in the passive layer of 83% after exposure to 95°C pure water.
- No experience with Nickel based alloys. Rouging has been observed with Hastelloy C-276, which is not surprising considering the lower Cr content.
- Titanium stabilized materials: valves and regulating valves in WFI systems are often made of 316Ti.

#### Cons:

- Due to cost and availability, 1.4539 und 1.4462 are only used in special cases.

### **Delta Ferrite Content**

- The delta ferrite criteria can be traced back to the BN 2 (Basler Norm, a guideline of the Swiss Chemical and Pharmaceutical Industries), where a very low delta ferrite content of 0.5% is defined. The original intention of BN2 was to just take the delta ferrite content into account. The delta ferrite limit was specified as a preventive measure and is not based on scientific proof. The limit is too strict and is not practical. It dictates the use of steel, which is considerably more expensive and compliant welds are



# ISPE

Presents:  
**Technical Documents**  
for the Pharmaceutical Manufacturing  
and Biotechnology Industries

Save  
on these great  
titles and more!  
**20%**

- *ISPE Good Practice Guide: HVAC*
- *ISPE Good Practice Guide: Maintenance*
- *ISPE Good Practice Guide: Good Engineering Practice*
- *GAMP® 5: A Risk-Based Approach to Compliant GxP Computerized Systems*
- *GAMP Good Practice Guide: Electronic Data Archiving*
- *ISPE Baseline® Guide: Active Pharmaceutical Ingredients, a Revision of Bulk Pharmaceutical Chemicals*

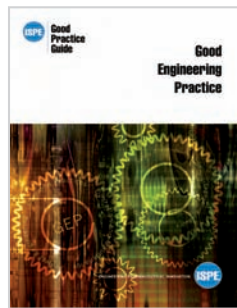

## ISPE Good Practice Guide: Good Engineering Practice

Item # IGPGEPE  
Member: \$145 / €105  
Nonmember: \$215 / €155

- Published December 2008  
This first edition of the ISPE Good Practice Guide: Good Engineering Practice covers the complete lifecycle of engineering from concept to retirement. The Guide aims to promote a common understanding of the concept and principles of GEP and explains the term "Good Engineering Practice." It describes the fundamental elements existing in pharmaceutical and related industries, and identifies practices, demonstrating how GEP concepts may be applied in the pharmaceutical industry considering the entire range of pharmaceutical engineering activity, as well as key attributes of GEP, including how GEP relates and interfaces with GxP.

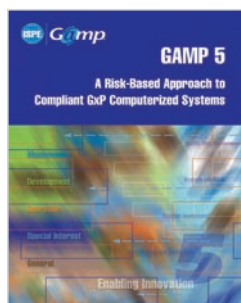

## GAMP® 5: A Risk-Based Approach to Compliant GxP Computerized Systems

Item # 5BOUNDUS/5BOUNDEU  
Member Price: \$250 / €185  
Nonmember Price: \$450 / €375

- Published February 2008  
Provides pragmatic and practical industry guidance to achieve compliant computerized systems fit for intended use in an efficient and effective manner. Describes a flexible risk-based approach to compliant GxP regulated computerized systems, based on scalable specification and verification. Points to the future of computer systems compliance by centering on principles behind major industry developments such as PQLI; ICH Q8, Q9, Q10; and ASTM E2500.



## ISPE Baseline® Guide: Active Pharmaceutical Ingredients, a Revision of Bulk Pharmaceutical Chemicals

Item # API0607  
Member Price: \$200 / €145  
Nonmember Price: \$400 / €335

- Published June 2007  
The first revision in the Baseline Guide series incorporates new regulations and guidance, such as: ICH Q7, ICH Q9, *GAMP® 4*, 21 CFR Part 11, Guidance for Industry, Sterile Drug Products Produced by Aseptic Processing – Current Good Manufacturing Practice (cGMP), FDA Draft Guidance for Industry PAT – Framework for Innovative Pharmaceutical Manufacturing and Quality Assurance, and much more.



Bookmark: tear along the lines

Offer valid at the ISPE 2009 Strasbourg Conference, 28 September-1 October 2009. Discount applies to ISPE Members only.

ENGINEERING PHARMACEUTICAL INNOVATION



considerably more difficult to achieve.

- Many of the participants have found that 3% is a more feasible limit. Since several participants also have had positive experience with considerably higher delta ferrite levels (no unusual rouging observed), 5% was suggested as the maximum for a preventive measure. It should be noted that calling 5% a preventive measure against rouging is not quite correct as lower delta ferrite levels won't have a negative effect on rouging, but could drive up the material costs.
- The goal (specification) should be 3%. Specifying < 3% is not recommended based on the experience of the group. An absolute maximum value of 5% should not be exceeded.
- A complete lack of iron can result in a significantly higher susceptibility to heat cracks and require the use of special weld filler metal.
- This aspect is overvalued regarding its potential negative influence on rouging. The delta ferrite has a more elevated Cr content and is fundamentally more resistant to rouging than austenitic (bulk) structure.
- This does not protect against rouging!
- The limit for delta ferrite was created as a measure of corrosion resistance and it can be used as proof of weld quality. The delta ferrite measurement is an economical and useful method to test weld quality if the weld filler material is fully alloyed.
- The delta ferrite content does not have an effect on the prevention of rouging.

## Surface Quality

*Stainless steel is always produced with a specific surface quality. The many variations, which are common for piping, are well defined in industry standards. There also are standards which described terms and conditions for delivery.*

### Common Design:

- Seamless tubing or longitudinal welds
- Mechanically polished or honed (bright finish, bright rolled, and cold drawn)
- Not pickled, just rinsed with water

### Pros:

- More economical than electro polished tube

### Cons:

- These surface qualities are often treated in situ. *With the exception Ti or Nb stabilized steel, all steel is available with electro polished surfaces, which can lead to further improvement*
- A roughness of Ra < 0.8 µm should be specified

### Pros:

- Due to the reduced surface area and the more compact, clean (free from defects) passive layer in comparison to non electropolished surfaces, electro polished surfaces generally show less tendency to rouging.

*Continued on page 52.*



## Pharmaceutical Online Is The Online Industry Standard



### Visit The NEW Pharmaceutical Online

An improved Pharmaceutical Online is now live, putting the latest technical, operational, and regulatory information about the global pharmaceutical development and production industry at your fingertips. A host of new features makes it easier than ever before to find exactly what you need, whether it's product overviews, industry news, technical articles, or anything else related to the field. Visit us at [www.pharmaceuticalonline.com](http://www.pharmaceuticalonline.com).

### Join the community and benefit from...

#### Rich Content

- Latest news and groundbreaking research
- Technical articles, case studies, and white papers
- Product, service, and solution information
- Video demonstrations, datasheets, and other free downloads

#### Site Resources

- Locating and sourcing products and services
- Keeping up with industry trends
- Interacting and collaborating with your peers

#### Free Newsletter

- Delivered every Tuesday and Thursday straight to your Inbox

Join the community today at [www.pharmaceuticalonline.com/signup](http://www.pharmaceuticalonline.com/signup)



- Better cleanability with higher surface quality

## Cons:

- Treatment with strong acids roughens the surface.
- Special care must be taken if any secondary welding is required.
- The welds in the pipe system can influence the surface quality.

## Welding Procedures

The Processing of the materials should be clearly defined, while taking into account the following criteria:

- Goods-in quality control (QM, QS, documentation)
- Storage conditions and environment (low dust) should be specified

### A. Weld Preparation

- Cutting of non alloyed ferritic materials → these develop very aggressive particles.
- Cutting of alloyed materials leads to conversion to martensite (magnetic, less corrosion resistant).
- Do not use a cutting disc, grinder.

### B. Welding Procedure

- Define welding procedure in advance (orbital or manual)
- Develop and qualify site specific welding procedures
- Welder's qualifications should correlate to the qualified welding procedures (see above)
- Automatic welding procedures (MIG, WIG)
- Laser, plasma welding procedures (tanks, etc.)
- Manual welds allowed as exceptions

### C. Weld Filler Metal

The corrosion resistance is improved when higher alloyed filler metal in comparison to the welded material is used. This also helps maintain a low delta ferrite content (experience: of the same kind as basic material).

### D. Weld Testing and Documentation

- All welds should be visually examined (naked eye, endoscope). A predetermined percentage of the welds should be documented with photos, DVD, or video.
- Examination of the weld formation and any discoloration should be included.
- An alternate testing method should be set for welds, which can not be visually examined (X-ray, sample weld before and after the true welding, etc.).

Further Documentation:

- Risk analysis, sample welds
- Weld plan, weld supervision, work instructions, welding procedure qualification
- Welder qualification
- "Technische Regel TR 153, "Gütesicherung von Schweißnähten an Apparaten und Rohrleitungen" issued by the Basel Chemical Industry (BCI). Available in German only.

## Engineering, System Design

### Influencing Factors

*How can rouging be avoided through engineering and system design of the water treatment plant?*

Various aspects under consideration of possible influencing factors, such as the design itself and monitoring, should be considered.

The following factors, which all could possibly effect the development of rouging, were considered in the workshop:

1. CO<sub>2</sub>
2. Temperature
3. Nitrogen
4. Oxygen
5. Particle Carryover
6. Ozone
7. Feedwater
8. Choice of Materials
9. Sanitization Process

#### 1. CO<sub>2</sub>

Elevated CO<sub>2</sub> concentrations cause a decrease in pH. This can lead to destabilization of the passive layer, particularly in hot systems (80°C).

#### 2. Temperature

Since rouging is a form of corrosion, it is expected that there is a system specific temperature above which the rouging will increase with further temperature increase.

#### 3. Nitrogen

Nitrogen blanketing of storage tanks removes the presence of oxygen in the tank atmosphere. This leads to a drop in the oxygen concentration of the water, reducing the redox potential, which results in a change in the passive layer.

#### 4. Oxygen

Oxygen facilitates the natural continuous re-passivation of the steel surface.

#### 5. Particle Carryover

Possible particle carryover from the water purification equipment or WFI still into the distribution system can be avoided or minimized through proper design.

- For example: by avoiding the use of non-alloyed steels for construction or piping material as well as through appropriate operating conditions.
- Further measures can only be defined once the possible formation mechanisms for ferrous compounds have been fully identified.

It is assumed that semi- intermediate- and final products (bulk) will pass particle filtration steps during the production process.

## 6. Ozone

Ozone, frequently used in cold storage and distribution systems, is thought to favorably effect the formation of the passive layer on the steel surface. However, ozone concentrations over about 1 ppm can lead to corrosion when chlorides are present and standard alloys, such as AISI 304 and 316 are used.

## 7. Feed Water

A detailed examination of the feed water quality is necessary during the equipment engineering phase to identify possible corrosion sources.

The goal is to eliminate iron, manganese, silica, CO<sub>2</sub>, and chlorides.

## 8. Choice of Materials

The choice of materials is handled in detail under "Choice of materials, QC."

## 9. Sanitization Process

Since high temperatures support corrosion, the temperature in a given system should be kept as low as possible without compromising safe operation. Frequent steam or hot water sanitizations could support rouge formation with the temperature and time being the deciding factors. Reasonable sanitization intervals should be set based on monitoring results (qualification phase, performance qualification, routine).

## Design

The following design criteria should be critically analyzed as part of a risk analysis. The focus should be on the effects on the equipment itself, on the operation of the equipment, and on the product.

- Sanitization and Cleanability
  - Drainability
  - Rinsable pure steam piping, for example, design the condensate piping system in a way in which it can be used to provide circulation during future chemical treatments (passivation, de-rouging).
  - Optimization of the cleaning procedure to simplify and reduce the amount of cleaning agent needed
- Allow for removable inspection spool pieces in the piping
  - Installation of easy to access spool pieces, such as elbows or bends at reference points in the piping system where rouging is expected
  - These pieces should be easily replaceable to allow detailed analysis with destructive testing in the lab when necessary.
- Demisters in the form of wire mesh should be avoided when possible, due to their large surface areas. Cyclone separators are acceptable.
- Welds are seen as a risk factor.
 

Correctly welded seams using WIG-process and with sufficient weld seam protection (inert gas shielded) do not add to the corrosion risk.

  - Cold bending offers a possibility to reduce the number of welds in a system, particularly for smaller pipe diameters (i.e., up to DN25).

- The material is more susceptible to local corrosion depending on the degree of cold forming; however, this isn't relevant for high purity water systems.
- Bending pipework is often preferred, due to economic reasons.
- CO<sub>2</sub> elimination
  - Protecting WFI stills and pure steam generators by installing selective degassing steps upstream
  - CO<sub>2</sub> traps can be installed on the product water storage tanks to prevent CO<sub>2</sub> from entering the distribution system. The CO<sub>2</sub> trap shouldn't be allowed to collect moisture as this can cause blockage.

## Monitoring

- Visual inspection using sight glasses, inspection pieces, or opening the pump housing
- Inline measurement
  - Direct quantitative measurement of rouge is not commercially available. Such monitoring technologies are currently in development.
- Other parameters and measurements
  - Measuring methods for parameters, such as pH, particle quantification and size, and CO<sub>2</sub> concentration are available. Their influence on rouging has not been conclusively studied or proven.

## Service and Maintenance

### Suggested Procedure

A risk analysis is a valuable starting point for the selection or determination of measures, which are to be implemented in the service and maintenance plan. The experience of the operator as well as the previous actions of the engineering or maintenance and quality control departments also should be taken into account.

The risk analysis should work out which parts of the system are critical and define the necessary treatment (to what extent, in which intervals, to which time point, and with which measures).

Figure 1 shows a possible procedure for the development of a plant specific service and maintenance plan.

It is generally accepted that suspended particles in low concentrations can be present and will be removed at filters.

The usual sample methods based on the Pharmacopeia will usually not discover the presence of particles.

The current findings show no influence of rouging on the mechanical stability of piping and components. It seems prudent to involve all parties, for instance, operator, quality control, engineering, and maintenance in the risk analysis process. Some of the issues and problems which they will address are:

- What are the possible effects on the product? Is it an API, end product?
- Can dissolved metallic ions occur (such as ferric ions) and what influence would this have on the product?
- Can adherent metal hydroxides occur (Fe-, Ni-, Cr-) and what influence would this have on the product?

*Continued on page 54.*

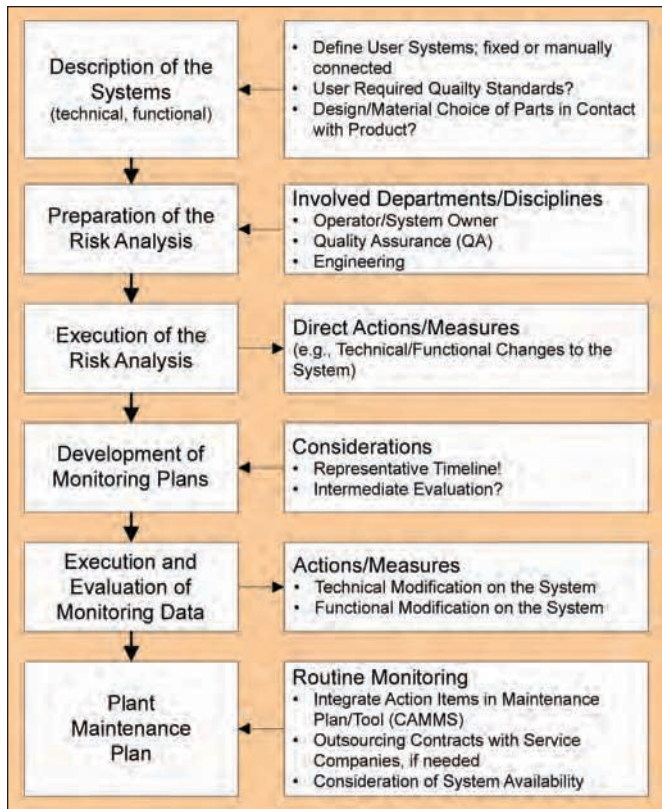

Figure 1. Flow chart risk analysis.

- Are filters in place which would be negatively impacted by particles?
- Can deposits form on measuring probes and sensors?
- If rouging occurs, could it negatively impact downstream plants or equipment?
- Are heat exchangers present and could these be negatively impacted?
- Are components, such as injectors, present whose function would be negatively impacted by the presence of particles?
- Further critical parts could be: pumps, instrument ports, tanks, valves, spray balls, forged components, vacuum molded components.
- Are unplanned events expected whose frequency would influence the availability of a plant, for example, when a cause analysis and subsequent service and maintenance measures are necessary after an OOS finding?
- Are measures to restore the defined state necessary after repairs or planned expansions or changes to the system, such as rinsing, passivation, pickling etc., after welding work has been done?
- Could the surface finish be changed by deposits? Will this favor biofilm formation?

## Inspection Program

A periodic monitoring program should be established to provide regular controls at the critical points of the system, which were defined in the risk analysis, to collect experience and information, for instance, through photo documentation. This provides the basis for the service and maintenance plan.

Both on and off-line tests can be used as well as testing the surface of spool pieces removed from the system.

An inspection plan can be created in order to collect enough information and empirical test results to allow optimization.

The following inspection and evaluation methods can be defined and used primarily:

- General visual inspection, e.g., through an inspection glass or with endoscope
  - Possible assessment: color (yellow, orange, red, brown, etc.) or surface finish (dull, shiny, morbid)
- Swab test (results: particles are removable, partly removable, not removable)
- Optical inline measurement
- Particle measurement, online/inline
- Filter: the water is filtered offline at 0.1  $\mu\text{m}$  and the filter membrane then undergoes laboratory analysis and evaluation, for instance, checking if discoloration or particles are present. This type of test should be carried out at predetermined intervals and the test results should influence the testing intervals.
- Inspection spool pieces: the following should be taken into account:
  - The piece should be representative of the system in terms of surface finish, material, etc.
  - Critical points in the system
  - They do not necessarily need to be built into straight piping segments.
  - It is better to use pieces with elbows, valves, or instruments. Procedure and use of spool pieces:
    - The spool piece is removed during maintenance and is used as a reference which is used as a sample for testing different cleaning methods.
- Electro-chemical methods

Monitoring data can be regularly evaluated on the basis of the monitoring plan. The results are used defining objective acceptance criteria and specifying the required state of the system.

## Maintenance Plan

One of the most important goals for evaluating the inspection results is their further use toward development of a system specific maintenance plan.

All results from the inspection, particularly from the spool pieces, should be taken into account in the development of the plan and in determining the steps which are to be taken. Depending on the actual situation, the plan can contain the following points and actions to be taken:

- location of the inspection or actions to be taken
- responsibility
- frequency or interval of the inspection or execution of the actions to be taken
- experience from previous cleanings, when available
- execution of a cleaning procedure, when necessary

- For especially critical cases in clean steam systems, a particle filter can be installed at the point of use. For this application, a filter size of  $< 0.1 \mu\text{m}$  is generally acceptable.
- Carbon dioxide absorbers can be used, for instance, on water storage tanks.

If the decision has been made that cleaning is necessary, the following issues should be decided, where appropriate:

- Should a general chemical clean take place?
- choice of the cleaning media (anodic clean, electro polishing)
- definition of success factors, using monitoring methods, such as conductivity, inspection spools etc., or use of passive layer measuring device, Ferroxyl test (ASTM-A380)
- definition of cycles and time periods, dependent on process
- In the case of older systems, special attention should be placed when defining parameters to take into account design, material, and components.

The operator must ensure that the following is met:

- Execution description exists and is accepted.
- Critical parameters, such as the treatment temperature and soak time are defined.
- The execution is properly documented.
- The scope of documentation is defined.
- The execution and scope of evaluating if the treatment was a success is defined.
- Procedure or maintenance plan is approved.

### Regulatory Aspects

In order to ensure that the current regulatory requirements are understood, it is advisable to keep up to date on the available audit information (FDA Warning Letters) as well as literature and publications.

Should the regulatory agency check how rouging is handled, it should be possible to present and explain how the procedure defining the maintenance and inspection plan was conducted as well as the results.

The operator must ensure that cleaning (derouging), monitoring, etc. is documented. In particular, a treatment report should be available which documents the results (also with photos) and in which all relevant points are systematically addressed.

### About the Authors

The Critical Utilities D/A/CH is a local ISPE Community of Practice (COP) comprised of individuals from Germany/Austria/Switzerland with expertise in pharmaceutical water and steam. 

Visit the Critical Utilities (CU) COP on the ISPE Web site for discussions on other related topics ---  
<http://www.ispe.org/communitiesofpractice>

 **BUDZAR**  
INDUSTRIES, INC.

Your Single Source Solution Provider

## Director Series Reactor Temperature Control Module



### Features Include:

- ❖ Temperature Range from  $-80^{\circ}$  to  $+285^{\circ}\text{C}$
- ❖ Stainless Steel Construction
- ❖ Sizes from 20 Liter to 500 Gallon Reactors
- ❖ Jacket Delivery Pressure Control
- ❖ Single Loop or Cascade Control
- ❖ General Duty or Explosion Proof Classification
- ❖ PLC Control, Data Logging & Trending Software, Self Tuning for Accuracy  $\pm 1^{\circ}\text{C}$

Budzar Industries has specialized in process fluid heat transfer systems since 1975 and has earned a global reputation for quality and ingenuity in the design, engineering, and manufacturing of temperature control systems. Budzar Industries systems are found throughout the world, delivering accurate temperature measurement and control to the production of pharmaceuticals, chemicals, petroleum, rubber, power, steel, food, and plastics.

### Budzar Industries

38241 Willoughby Parkway  
Willoughby, Ohio 44094  
440-918-0505 • [www.Budzar.com](http://www.Budzar.com)

## Europe

### **Denmark**

#### *Defects Medicines – Packaging<sup>1</sup>*

The annual report on product defects and recalls for 2008 covering both marketed and non-marketed medicines was published by the Danish Medicines Agency. This report showed most of the recalls were issued because of wrapping defects. Reports on the lack of adherence to good manufacturing practice regulations also were sent to the agency as a result of inspections carried out by various European medicines agencies.

The most current defect reported was regarding packaging. Most of the defects were related to packaging or repackaging processes and to wrapping – usually plastic – and mainly concerned the printing of incorrect expiry dates on packaging.

Only five side effects related to product defects were reported in the 177 reports filed with the agency.

### **United Kingdom**

#### *Notifying the GLPMA of Changes within a GLP Test Facility<sup>2</sup>*

In April 2009, the Good Laboratory Practice Monitoring Authority (GLPMA) released a guidance advising manufacturers about the declaration form to the GLPMA that needs to be filled out when there are changes made within a GLP test facility. This GLP TEST FACILITY form was part of the risk assessment process settled by the GLPMA in order to ensure public safety and compliance with the Good Laboratory Practices (GLP) standards. Changes to be notified to the GLPMA will be the volume of GLP work undertaken, types of GLP activities undertaken, contracting out of GLP functions, facilities and equipment, personnel aspects and other changes such as changes in company ownership or changes to the management or organization structure.

#### *GMP – Update to Labeling Requirements for Pandemic Antivirals<sup>3</sup>*

The Manufacturing and Wholesale

Dealing Regulations SI 2005 No 2789 was replaced by the regulation SI 2009 No 1164 in May 2009.

Amendments have been made which affect the labelling requirements for antiviral medicines for children under the age of one year in a pandemic situation, allow for notice of urgent safety measures to be given as soon as possible to the licensing authority and an ethics committee during a period in which a disease is pandemic and is a serious risk to human health, and enable the wholesale distribution of unauthorised medicinal products in response to the suspected or confirmed spread of health-harming substances.

The regulation came into force on 8 May 2009.

#### *EudraGMP Database<sup>4</sup>*

The Medicines and Healthcare products Regulatory Agency (MHRA) implemented a new system that will automatically transfer data from its medicines database Sentinel onto the European database EudraGMP launched in 2007 and maintained by the European Medicines Agency.<sup>1</sup> The EudraGMP database was launched in order to facilitate the exchange of information on compliance with good manufacturing practice.

Information on manufacturing and importation authorisations and post-inspection good manufacturing practice certificates issued by the MHRA will be automatically published on the EudraGMP.

The MHRA Director of Information Alison Davis said this system will ensure the information in EudraGMP remains current while reducing the burden of data transfer.

#### *Turkey GMP<sup>5</sup>*

The GMP guideline was revised in accordance with the EMEA and ICH Guidelines and the specific conditions in Turkey. It was approved and published on 11 May 2009. During inspections performed by the MoH, the manufacturers of pharmaceutical preparations and active ingredients will be required to comply with provisions of this Guideline.

## International

### **ASEAN Countries**

#### *GMP Inspection Reports<sup>6</sup>*

In April at the Pattaya summit in Thailand, a mutual recognition agreement was signed by 10 ASEAN countries agreeing to recognise certifications and/or inspection reports on good manufacturing practice of pharmaceutical companies within the region.

All ASEAN member states are expected to fully implement this mutual recognition agreement by the 1st January 2011 and the GMP certificates and reports will be used as the basis granting approvals, delivering licenses to the manufacturer, supporting post market assessments of conformity for products and providing information on manufacturer facilities or testing laboratories in the ASEAN region.

In this agreement, the format that drug regulatory authorities will have to follow when issuing the GMP inspection reports is specified. Information on the dosage forms manufactured at the facility and manufacturer compliance with the GMP requirements will be captured in inspection reports.

Under this agreement, where a manufacturing facility has not been inspected recently, a Member state can request its counterpart to carry out a specific and detailed inspection. The aim of this GMP mutual recognition agreement is to move closer to its 2015 goal of a single Southeast Asian market. The agreement will help to ensure the safety, quality and efficacy of medicinal products manufactured in the region.

Consumers will benefit from greater confidence in the safety of medicines being sold and the business costs of manufacturers will be lowered by the mutual recognition of inspection reports as they will not be required to undergo a repeated testing or certification process for marketing their products in the different member states.

### **Brazil**

#### *Manufacturing Resolutions for Influenza A Vaccines (H1N1)<sup>7</sup>*

The National Health Surveillance Agency (ANVISA) issued on 7 May 2009 the Resolution RDC 18 for Manufactur-

ers of influenza A vaccines (H1N1) in Brazil.

This resolution states that the manufacturing of influenza A vaccines (H1N1) in Brazil will be previously authorized in Brazil provided that the following requirements are fulfilled:

- manufacturers hold a Marketing Authorization granted by ANVISA for manufacturing seasonal influenza A vaccines
- manufacturing takes place in sites authorized by ANVISA for the manufacturing of influenza vaccines
- the Influenza A viral strain (H1N1) used for the manufacturing is the one issued by the World Health Organization

ANVISA will need to be formally notified by the Marketing Authorization Holder/ manufacturer immediately after reception of the viral strain for production of the vaccine.

From the reception of the strain, the whole manufacturing process of the vaccine will be under supervision by a Regulatory Technical Committee formally established by ANVISA.

This resolution came into force on 7 May 2009.

### **India** **"Pharma Zones"**<sup>8</sup>

The Indian Central Drugs Standard Control Organisation (CDSCO) is seeking feedback on its plans to create dedicated climate controlled "pharma zones" within the cargo area of all major airports and seaports.

Proper storage and examination of pharmaceutical products meant for import or export in accordance with good manufacturing and distribution practices will be performed in these zones mentioned by the CDSCO. This system aims to preserve the quality, safety and efficacy of pharmaceuticals being transported and this will ensure no cross contamination of medicines with other products. The deadline for comments on the draft plan was 15 June 2009.

In India, the Indira Gandhi International airport in Delhi will be the first zone to be set up which is a major

pharmaceutical trading hub.

An area of approximately 3,700 m<sup>2</sup> will be allocated for this zone and among other things, it would include a cold room facility with varied temperature zones (-20° to 8°C), a comfort zone (with temperatures below 25°C) for the examination of pharmaceuticals, and a basic testing facility to check samples of pharma products.

Separately, new measures have been initiated by the Indian Ministry of Commerce and Industry in order to combat criticism from some countries that drugs being exported by Indian manufacturers do not meet international quality standards.

A public notice was issued by the Directorate General of Foreign Trade to inform new procedures/guidelines to strengthen the enforcement mechanism available under the Drugs and Cosmetics Act 1940, to ensure that counterfeit drugs do not get exported from India. As per this notification a copy of the certificate of analysis issued by the manufacturer for the subject product along with other documents will be requested to every exporter of drugs and pharmaceuticals, at the time of shipment.

### **New Zealand** **GMP Code Updated**<sup>10</sup>

Proposals to change the New Zealand Code of Good Manufacturing Practice have been announced by the New Zealand's regulatory agency Medsafe. Comments on the proposals from Stakeholders were until 15 May 2009. These proposals aim to bring the New Zealand Code of Good Manufacturing Practice in line with the international GMP codes.

These updates intend to incorporate developments in international codes of GMP and developments with respect to new or improved technologies; to ensure New Zealand's requirements and manufacturers remain up to date in an increasingly global manufacturing environment; improve the specific guidance for particular industry sectors - for example, manufacturers of sterile medicines and of active pharmaceutical ingredients; improve the guidance for key components of quality manage-

ment - for example, validation and qualification activities; and to support provision of GMP certification to New Zealand's mutual recognition agreement partners on behalf of New Zealand manufacturers exporting medicines to other countries.

Stakeholders were expected to be informed by Medsafe of its final decision on 15 June and will publish the updated edition of the NZ Code of GMP on 1 July, which will come into effect on 1 September.

### **Philippines** **Streamlining Drug Registration Processes**<sup>9</sup>

Measures to streamline the registration process of pharmaceutical products have been proposed by the Philippines Bureau of Food And Drugs. These measures aim at improving patient access to medicines. The use and implementation of electronic data messages, documents, and signatures for product registration can be implemented in July if the proposal is finalised.

The proposed measures have been outlined in the form of a draft administrative order, which would apply to all pharmaceutical products for human use (except traditional and herbal medicines). It would also cover all manufacturers, traders, importers, exporters and distributors of these products.

By this order for a drug not registered with the agency, manufacturing, importing, exporting, selling, distributing, transferring, promoting or advertising would become illegal. Comments on the proposed measures were accepted until 30 April 2009.

### **United States** **OTC - New Labeling for Analgesics, Antipyretics and Antirheumatics**<sup>11</sup>

The Food and Drug Administration (FDA) released on 28 April 2009 final rule 21 CFR Part 201 (Final rule) for manufacturers of Over-The-Counter (OTC) Internal Analgesic, Antipyretic, and Antirheumatic (IAAA) drug products. Manufacturers of these drugs will need to revise their labeling in order to include warnings about potential safety

*Concludes on page 58.*

risks such as internal bleeding and liver damage, associated with the use of these popular drugs like acetaminophen and nonsteroidal anti-inflammatory drugs (NSAIDs) like aspirin, ibuprofen, naproxen, and ketoprofen.

This new labeling is required for all OTC IAAA drug products whether marketed under an OTC drug monograph or an approved new drug application (NDA).

According to the rule manufacturers must relabel their products within one year to include a warning and ensure that the active ingredients of these drugs are prominently displayed on the drug labels on both the packages and bottles.

This final rule from the FDA is aimed at helping consumers to use these products safely.

## *Ongoing Safety Review of Botox and Botox Cosmetic<sup>12</sup>*

The FDA published a safety review in April 2009 – a follow up to the 8 February 2008 Early Communication about an Ongoing Safety Review of Botox and Botox Cosmetic (Botulinum toxin Type A) and Myobloc (Botulinum toxin Type B).

As the result of an ongoing safety review, the FDA has notified manufacturers of licensed botulinum toxin products of the need to strengthen warnings in product labeling, and add a boxed warning, regarding the risk of adverse events when the effects of the toxin spread beyond the site where it was injected.

FDA also has notified the manufacturers that development and implementation of a Risk Evaluation and Mitigation Strategy (REMS) is necessary to ensure that the benefits of the product outweigh the risks.

In addition, FDA is requiring the manufacturers to submit safety data after multiple administrations of the product in a specified number of children and adults with spasticity to assess the signal of serious risk regarding distant spread of toxin effects.

## References

1. The Regulatory Affairs Journal, May 2009.  
DMA, Report: Product Defects and Recalls of Pharmaceuticals in 2008, 31 March 2009, <http://www.laegemiddelstyrelsen.dk/1024/visLSArtikelBredSkema.asp?artikelID=14893#forfalskede>
2. <http://www.mhra.gov.uk>
3. Published by the Stationery Office, <http://www.opsi.gov.uk>
4. The Regulatory Affairs Journal, May 2009.  
MHRA press release, 6 May 2009, <http://www.mhra.gov.uk/NewsCentre/Pressreleases/CON046496>
5. IEGM (General Directorate of Pharmaceuticals and Pharmacy), <http://www.ieg.gov.tr>
6. The Regulatory Affairs Journal, May 2009.  
The ASEAN member states are Brunei Darussalam, Cambodia, Indonesia, Laos, Malaysia, Myanmar, Philippines, Singapore, Thailand and Vietnam.
  - ASEAN Bulletin, 10 April 2009, <http://www.aseansec.org/Bulletin-Apr-09.htm#Article-6>
  - ASEAN, Fact sheet on the MRA, 10 April 2009, <http://www.aseansec.org/Fact%20Sheet/AEC/2009-AEC-026.pdf>
  - ASEAN Sectoral Mutual Recognition Arrangement for good manufacturing practice (GMP) inspection of manufacturers of medicinal products, 10 April 2009, <http://www.aseansec.org/22481.pdf>
7. The Regulatory Affairs Journal, May 2009.  
Diário Oficial da União (DOU) No. 85, of 7 May 2009, <http://www.in.gov.br>
8. • CDSCO, General Notice, 14 May 2009, <http://www.cdsc.nic.in/General%20Notice.doc>
- CDSCO, Presentation on Pharma Zone, 14 May 2009, <http://www.cdsc.nic.in/Pharma%20Zone.pdf>
- Pharmexcil, Circular to members, Ref: PXL/H.O./CIR-013/2009-10, 14 May 2009, <http://www.pharmexcil.com/v1.aspx/viewNewsBulletin.aspx?ID=540>
- Directorate General of Foreign Trade, Public Notice No. 173 (RE-2008)/2004-2009, 13 April 2009, <http://164.100.9.245/exim/2000/pn/pn08/pn17308.htm>
9. The Regulatory Affairs Journal, May 2009.
  - BFAD, Streamlined Rules and Regulations on the Registration System of Pharmaceutical Products for Human Use Amending for this Purpose Administrative Order No 67 s. 1989, Issuances Supplementing the same, and for other purposes, 23 April 2009, <http://www.bfad.gov.ph/default.cfm?isdraft=1&cid=673>
  - BFAD circular, 21 January 2009, <http://www.bfad.gov.ph/cfc/pdf.cfm?pdfid=1108>
  - Philippines government press release, 21 May 2009, [http://www.gov.ph/index.php?option=com\\_content&task=view&id=2000617&Itemid=2](http://www.gov.ph/index.php?option=com_content&task=view&id=2000617&Itemid=2)
10. The Regulatory Affairs Journal, May 2009.  
Medsafe, Proposed update to the New Zealand Code of Good Manufacturing Practice, 16 March 2009, <http://www.medsafe.govt.nz/hot/Consultation/GMP%20Review.asp>
11. <http://www.Idrac.com>; FDA, Medicines Agency, <http://www.fda.gov>
12. <http://www.Idrac.com>; FDA, Medicines Agency, <http://www.fda.gov>

*This information was provided by Frank Sayala and Rohini Chari, Pharmaceutical Research Associates (UK).*

# ISPE09

## Annual Meeting

### Thriving In A Survival Environment

8 - 11 November • Manchester Grand Hyatt San Diego • San Diego • California, USA

#### Eleven Session Tracks:

- Product development
- Facilities and equipment
- Information systems
- Supply chain management
- Production systems
- Regulatory compliance
- Quality systems
- Project management
- Investigational products
- Suppliers
- Survival-focused

Watch for details and online registration at [www.ISPE.org/annualmeeting](http://www.ISPE.org/annualmeeting).

Exhibit and Sponsorship Opportunities Available

ENGINEERING PHARMACEUTICAL INNOVATION





## PQLI Tours Asia

As a key part of PQLI's global strategy spearheading with practical implementation examples of ICH guidelines Q8, Q9, and Q10, interactive sessions were held at the Indian Affiliate Annual Meeting in Mumbai on 13 and 14 April and at the Japan Affiliate Annual Meeting in Tokyo on 16 and 17 April.

A Western team was active at both meetings and included Jim Spavins, Vice President, Global CMC, Pfizer Inc.; Roger Nosal, Executive Director, Regulatory CMC, Pfizer Global Research; and Chris Potter, CMC Consultant and Technical Project Manager for ISPE's PQLI® Initiative. Ranjit Deshmukh, Senior Director of Wyeth, was a member of the team in Mumbai.

Input was provided by US FDA speakers Rick Friedman, Director, FDA/DMPQ, who discussed global supply chain challenges for regulators and industry, and Tara Goen, Compliance Officer, FDA/DMPQ, who discussed the recent FDA draft guidance on process validation at both meetings. Both presentations were pre-recorded. In Tokyo, Yukio Hiyama, Chief, Third Section, Division of Drugs, NIHS, presented and was part of the Q&A session. Hiyamasan summarized the current position

following the introduction of ICH Q8, Q9, and Q10 in Japan, particularly the status of the various MHLW work groups.

Spavins led the Western team with a presentation on the benefits and value to the industry of conducting enhanced approaches using Quality by Design (QbD). Nosal provided Pfizer's experiences in filing QbD submissions and also summarized the latest activities of PQLI teams working on Critical Quality Attributes/Critical Process Parameters (originally Criticality), Design Space, and Control Strategy topics. Potter provided an overview of the PQLI vision and status, discussed the recently published *Journal of Pharmaceutical Innovation (JPI)* paper on application of QbD to existing products, as well as summarized a case study on the application of real-time release testing to a solid dosage form provided by AstraZeneca. In Mumbai, Deshmukh presented a Wyeth case study.

In Japan, a vote was held on potential PQLI future topics, with process vali-

dation and scale-independent design space being very clear winners.

The Indian organizing committee was led by Gopal Nair, under the overall leadership of Ajit Singh. Nair was supported by Manasi Baidur from ISPE India. The PQLI session was chaired by R. Raghunandan, Director of ISPE India.

In Japan, the meeting organizing committee was chaired by Tatsuro Miyagawa, Executive Vice-President, Daiichi Sankyo Propharma, who was supported by Natsumi Sahara from ISPE Japan. Yoshio Kitazawa, Chairman of the Japanese PQLI Steering Committee, co-chaired the PQLI session with Potter.

The recorded version of the PQLI webinar available is at [www.ISPE.org/pqli](http://www.ISPE.org/pqli). 



## Global Regulators and ISPE Members Make for Washington Conference Success

Multiple time zones and great distances could not stop pharmaceutical industry leaders from sharing their knowledge at ISPE's Engineering Regulatory Compliance Conference held in Washington, D.C., USA from 1–4 June. For the first time at an American ISPE conference, select content from among its lineup of speakers was recorded and is accessible as downloadable webinars for those industry professionals who were unable to attend. Content was also delivered virtually via live Webcasts and live online speaker presentations. To access the selection of Washington Webcasts and Webinars, visit [www.ispe.org](http://www.ispe.org).

A popular seminar was "Global Supply Chain Integrity and Anti-counterfeiting" – co-sponsored by IPEC–Americas.

This seminar brought together a panel of industry leaders and US FDA regulators to help the pharmaceutical industry address recent concerns about the integrity of today's complex pharmaceutical supply chain and to help companies assure a safe, efficacious drug supply.

Industry leaders from around the world were also able to deliver their content virtually via live Webcasts, during which on-site and off-site participants could participate in Question and Answer periods with speakers located in India and Italy. Attendees rated these sessions very highly and felt that the virtual Q&A exchanges were as good as if every participant was on site. 

## ISPE Launches Three New Online Learning Product Lines

ISPE has introduced three new Online Learning products: the ISPE 2009 Washington Conference Session series, the Certified Pharmaceutical Industry Professional™ (CPIP™) Online Course series, and the Good Manufacturing Practices (GMP) Online Training Course series.

“With the increased restrictions placed on executive travel, and the demand for education remaining stronger than ever, ISPE’s latest Online Learning offerings will truly accommodate a multitude of training needs in today’s challenging economy,” said Robert P. Best, President and CEO of ISPE. “Having access to an expert directly from their desktops is what most pharmaceutical professionals want, and as the leader in pharmaceutical education, ISPE can supply that with its expanding library of Online Learning opportunities.”

ISPE has made select sessions from its successful 2009 Washington Conference available as downloadable Webinars. Those industry professionals who were unable to attend the conference can still benefit from the numerous global regulators – including those from the World Health Organization and the U.S. Food and Drug Administration – who shared their expertise with participants on topics ranging from global supply chain integrity to validation and quality by design.

*“With the increased restrictions placed on executive travel, and the demand for education remaining stronger than ever, ISPE’s latest Online Learning offerings will truly accommodate a multitude of training needs in today’s challenging economy...”*

**Robert P. Best, President and CEO of ISPE**

The Certified Pharmaceutical Industry Professional (CPIP) Online Course series provides a broad range of learning opportunities for career growth and professional development. The CPIP series of self-directed online courses is designed for two groups: those pharmaceutical professionals who are hoping to obtain general pharmaceutical industry knowledge from drug product development through manufacturing, as well as to those who are seeking industry-wide recognition of accumulated experience via the CPIP credential.

Developed in cooperation with the global leader in GMP training, the GMP Institute, the pre-recorded Good Automated Manufacturing Practice Training Online Course series is being developed and reviewed by expert instructors and international regulatory advisors. Each 60 or 90 minute event will provide an interactive learning experience that includes a pre-assessment to identify knowledge gaps, a downloadable course presentation for note-taking, learning reviews/assessments highlighting important points, links to various web pages, an online resource handout as a quick reference for all web links discussed, and a summary of the assessments to gauge knowledge gained.

Each of these webinars can be found in ISPE’s Online Learning Catalog, which features course titles for every recorded ISPE webinar and online course sorted by topic, title, and area of interest. Each event is led by an industry leader, subject matter expert, or a member of one of ISPE’s Communities of Practice (COPs) and is available in a convenient and cost-effective recorded format at [www.ISPE.org/onlinelearning](http://www.ISPE.org/onlinelearning). 

## ISPE Strasbourg Conference to Focus on Managing Knowledge through Science and Risk Assessment

The ISPE Strasbourg Conference will be held 28 September – 1 October at the Palais des Congrès, Strasbourg, France. The conference will feature the following seminars:

- Commissioning and Qualification: Practical Applications of Science and Risk-based Approaches to Validation
- Disposables and Containment Technology in Biomanufacturing: Managing Risk, Reducing Cost
- GAMP® 5 Operational Aspects
- Barrier Isolation Forum, Innovation Updates and New Case Studies
- Investigational Medicinal Product (IP) Innovation in a Regulated Environment
- PQLI®: Global Realisation and Implementation of the ICH Quality Vision

Training Courses:

- Basic Principles of Computerised System Compliance (GAMP 5)
- Cleaning Validation Principles

More detailed information about this event is available at [www.ISPE.org](http://www.ISPE.org). 

Continued on page 62.

## Event to Showcase Facility of the Year Award Winners from DACH Region

In the last three years, companies from the ISPE Germany/Austria/Switzerland (DACH) Affiliate have won many of the awards presented by ISPE's Facility of the Year Awards program, including an Overall Winner award. To highlight the latest state-of-the-art developments being implemented by these award-winning manufacturers and their suppliers, the **Facility of the Year: Innovation Showcase** will be held **2-3 November 2009** in **Ulm, Germany**.



The event will include case studies on innovation and background on the projects, Q&A sessions, a networking reception, and site visits to some of the award-winning facilities. Presentations will cover research, development, clinical trials manufacturing, biologics, vaccines, sterile fill/finish, and oral solid dosage production. Speakers will illustrate innovative project execution, facility integration, process design, and operational excellence. More detailed information about this event is available at [www.ISPE.org](http://www.ISPE.org). 

## New ISPE Technical Document and Webinar Offer Pragmatic Solutions to Maintenance Issues

The new *ISPE Good Practice Guide: Maintenance* provides current, established practices to help achieve technical and regulatory accuracy and cost-effective compliance whether in a new maintenance program or reviewing an existing program for effective strategy and efficiency. The Guide is intended to be used as a tool for the development, implementation, and execution of a maintenance program in a manufacturing environment. The Guide is focused on maintenance in cGMP areas where maintenance strategies, plans, SOPs, and quality procedures and policy application are developed.

Because the Guide was written by a group of maintenance professionals from many pharmaceutical companies from around the world – and reviewed by the US Food and Drug Administration – it is in fact a benchmarking tool. The key concepts in this Guide can be used knowing that they have general acceptance in the industry.

As with all ISPE technical documents, the *ISPE Good Practice Guide: Maintenance* utilizes a practical, pragmatic, non-theoretical approach, giving the reader guidance on solving problems and serving as a valuable tool for addressing regulatory inspections and compliance issues. Of particular interest in the Guide is the “Reliability Curve” graphic illustration and the Table of Regulatory Citations.

In tandem with the global release of the *ISPE Good Practice Guide: Maintenance*, is the offering of a 60-minute webinar, “Launch of the ISPE Good Practice Guide: Maintenance.” This webinar identifies how the new guide can provide solutions for structuring a maintenance program and provides practical tools that will help ensure quality and compliance of maintenance operations. More detailed information on the Guide and Webinar is available at [www.ISPE.org](http://www.ISPE.org). 

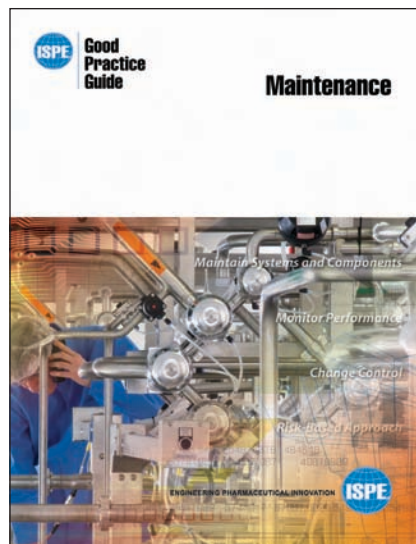

## Sichuan University Student Chapter Takes on Glossary Translation

The ISPE Student Chapter at Sichuan University is still new, but the Student Members have already completed a major project that will significantly impact the pharmaceutical engineering industry in China. At the request of the China Affiliate Steering Committee, members of the Student Chapter agreed to undertake the translation of the ISPE glossary from English to Mandarin Chinese. They began work in the middle of January and finished at the end of April. The translation from A to Z totaled 5,963 words and phrases. In addition, they helped combine the material into several convenient groups for upcoming review by industry experts. The Sichuan University Student Chapter has 107 members and is led by President Zhang Yiwen. For more information, visit the ISPE China Affiliate Web site, which can be accessed through [www.ISPE.org](http://www.ISPE.org). 

# New Knowledge Briefs Published

ISPE just released the **Removal of “Use by Dates” from Clinical Trial Material Labels in the European Union** by Michael A. Arnold. This Knowledge Brief explains how – through a risk analysis – IVR/IWR technology may be a better alternative to the conventional method of managing “use by dates.” Guidance is also provided on how to notify authorities of an intent to use IVR/IWR technology.

Also new and available is **Dry Powder Sampling and the Containment of Hazardous Compounds** by Jonathan Lind. This Knowledge Brief provides a high level review of the requirements for the successful containment of hazardous compounds associated with dry powder sampling activities.

Knowledge Briefs are concise, summary documents that provide general information on issues, processes, and technologies impacting the contemporary pharmaceutical industry. Although it may contain technical content, Knowledge Briefs are written in terms a non-technical reader can understand and are intended to help industry professionals get up-to-speed quickly on a particular topic. Each brief includes links to additional ISPE resources such as technical documents, *Pharmaceutical Engineering* articles, webinars, Communities of Practice, and educational seminars and training courses to provide more specific and detailed information on the subject.

Knowledge Briefs are available for immediate download (free to ISPE Members, \$5 US / €3 for nonmembers) from [www.ISPE.org/knowledgebriefs](http://www.ISPE.org/knowledgebriefs). The following is a list of additional Knowledge Briefs:

## Overview: Regulatory Framework – US FDA

by Dr. Kate McCormick

This Knowledge Brief provides a basic overview of the US FDA's organizational structure and licensing procedures relevant to pharmaceutical manufacturing and regulation.

## Overview: Regulatory Framework – EMEA

by Dr. Kate McCormick

This Knowledge Brief provides a basic overview of the EMEA's organizational structure, responsibilities, and regulations relevant to the manufacture of medicinal products.



## Overview: Regulatory Framework – PIC/S and ICH

by Dr. Kate McCormick

This Knowledge Brief provides a basic overview of the establishment and purpose of these two organizations and PIC/S and ICH publications pertinent to the pharmaceutical manufacturer.

## Packaging Equipment: Slat Fillers

by James Hills

This Knowledge Brief provides a basic overview of the general concept and design of the slat filler and addresses several considerations important to achieving maximum operational efficiency.

## Reducing the Cost of Manufacturing

by John Nichols

This Knowledge Brief provides an overview of how Targeted Processes, Process Intensification, and Lean/Continuous Manufacturing will serve as key techniques and technologies to reduce the cost of pharmaceutical manufacturing today and in the future.

## Risk-Based Approaches to Cross Contamination

by Stephanie Wilkins

The concepts presented in this Knowledge Brief were developed from the *ISPE Baseline® Guide, the Risk-Based Manufacture of Pharmaceutical Products (Risk-MaPP) – A Guide to Managing Risks Associated with Cross Contamination*, which is currently being reviewed by the US FDA.

## Biotechnology Basics

Adapted from the ISPE Training Course on Biotech Basics This Knowledge Brief provides basic concepts explaining the science of biotechnology and how science and process are combined to lead to the manufacture of a human therapeutic product.

## Commissioning and Qualification of Biopharmaceutical Facilities

The information contained in this Knowledge Brief was extracted from the *ISPE Baseline® Guide: Biopharmaceutical Facilities*, authored by the Biopharmaceutical Manufacturing Facilities Baseline® Guide Task Team

This Knowledge Brief summarizes the considerations involved in the commissioning and qualification of a biopharmaceutical manufacturing facility.

## Quality by Design

by John Berridge, PhD

This Knowledge Brief provides and explains the basic elements of Quality by Design (QbD). 

## Architects, Engineers – Constructors

**CRB Consulting Engineers**, 7410 N.W. Tiffany Springs Pkwy., Suite 100, Kansas City, MO 64153. (816) 880-9800. See our ad in this issue.

**Parsons**, 150 Federal St., Boston, MA 02110. (617)-946-9400. See our ad in this issue.

## Cleanroom Products/Services

**AES Clean Technology**, 422 Stump Rd., Montgomeryville, PA 18936. (215) 393-6810. See our ad in this issue.

**Plascore**, 615 N. Fairview, Zeeland, MI 49464. (800) 630-9257. See our ad in this issue.

## Dust Collectors

**Farr APC**, 3505 S. Airport Dr., Jonesboro, AR 72401. (866) 530-5474. See our ad in this issue.

## Employment Search Firms

**Jim Crumpley & Associates**, 1200 E. Woodhurst Dr., Bldg. B-400, Springfield, MO 65804. (417) 882-7555. See our ad in this issue.

**Robert Drexler Associates, Inc.**, PO Box 151, Saddle River, NJ 07458. (201) 760-2300. See our ad in this issue.

## Instrumentation

**Hach Co.**, 5600 Lindbergh Dr., Loveland, CO 80539. (970) 663-1377. See our ad in this issue.

## Passivation and Contract Cleaning Services

**Active Chemical Corp.**, 4520 Old Lincoln Hwy., Oakford, PA 19053. (215) 676-1111. See our ad in this issue.

**Cal-Chem Corp.**, 2102 Merced Ave., South El Monte, CA 91733. (800) 444-6786. See our ad in this issue.

## Processing Systems

**GEA Process Engineering**, 9165 Rumsey Rd., Columbia, MD 21045. See our ad in this issue.

## Rupture Discs

**Fike Corp.**, 704 SW 10th St., Blue Springs, MO 64015. (816) 655-4546. See our ad in this issue.

## Sterile Products Manufacturing

**Process Tek - Sterility by Design**  
 INNOVATION, RELIABILITY & PROFESSIONALISM  
 R&D, Validation, GMP Auditing,  
 HACCP, Problem Solving and Training  
 for sterile products, packages & processes  
 Kailash S. Purohit, PhD  
[www.processtek.net](http://www.processtek.net) • [kaipurohit@processtek.net](mailto:kaipurohit@processtek.net)

## Temperature Control Systems

**Budzar Industries**, 38241 Willoughby Pkwy., Willoughby, OH 44094, (440) 918-0505. See our ad in this issue.

**CAL-CHEM CORPORATION**  
 NOT JUST ANOTHER CONTRACTOR, BUT A PARTNER...



*"Follow Through"*

"Follow Through" is critical in today's technical market. Cal-Chem offers today's industries solutions for a wide variety of precision cleaning and passivation, while preparing for tomorrow's challenges.



visit our web site for more information: [www.cal-chem.com](http://www.cal-chem.com)  
 or call us at:  
**800-444-6786**  
 Offices conveniently located on the East and West Coast

**ISPE Good Practice Guide: Maintenance**



**Now Available!**

Order on-line at [www.ISPE.org/publications](http://www.ISPE.org/publications)

**JIM CRUMPLEY & ASSOCIATES**  
**Pharmaceutical Recruiting Specialist**  
 Put our expertise to work for you in:

- Facilities
- Project
- Process
- Validation
- Automation
- Quality Engineering

1200 E. Woodhurst Drive, B-400 • Springfield, MO 65804  
 Phone: 417-882-7555 Fax: 417-882-8555  
 E-mail: [recruiter@crumpleyjobs.com](mailto:recruiter@crumpleyjobs.com)  
 Web site: [www.crumpleyjobs.com](http://www.crumpleyjobs.com)  
*We've been getting results since 1977!*

## Validation Services

**Commissioning Agents, Inc.**, 1515 N. Girls School Rd., Indianapolis, IN 46214. (317) 710-1530. See our ad in this issue.

## Valves

**Gemu GmbH & Co.**, Fritz-Mueller-Str. 6-8, D-74653 Ingelfingen, Germany. +49 7940123-0. See our ad in this issue.

## Vial Traying Systems

**Hurst Corp.**, Box 737, Devon, PA 19333. (610) 687-2404. See our ad in this issue.

## Water Treatment

**Elettracqua Srl**, Via Adamoli 513, 16141 Genova, Italy. +39 0108300014. See our ad in this issue.

**MECO**, 12505 Reed Rd., Suite 100, Sugar Land, TX 77478. (800) 421-1798. See our ad in this issue.

**Siemens Water Technologies**, 10 Technology Dr., Lowell, MA 01851. (978) 934-9349. See our ad in this issue.

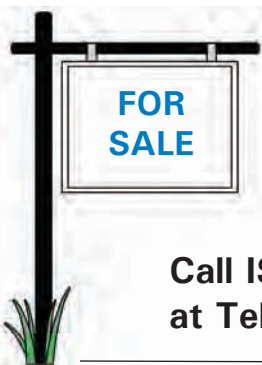

## Advertising Space Available

Call ISPE Director of Sales Dave Hall at Tel: + 1-813-960-2105.

Inc. 1955



## ACTIVE CHEMICAL CORP.

### SPECIALISTS IN . . .

#### — LABORATORY CONTROLLED —

- CHEMICAL CLEANING SERVICES OF HEAT EXCHANGE EQUIPMENT
- PASSIVATION OF STAINLESS STEEL PIPING
- STERILIZATION OF PIPING & EQUIPMENT
- SOFTENERS & DEIONIZERS
- RECONDITIONING OF FILTERS & ION EXCHANGERS
- WATER TREATING CONSULTANTS
- BOILER & COOLING WATER CHEMICALS

#### SERVICE CONTRACTS

**(215) 676-1111**

4520 Old Lincoln Hwy.,  
Oakford, PA 19053



## DELABELING SOLUTIONS

for

- SYRINGES\*
- CARTRIDGES
- GLASS VIALS
- PLASTIC VIALS
- METAL CANISTERS

\*new 2009

Information:  
[www.hurstcorp.com](http://www.hurstcorp.com)

**Other HURST products:**  
Automatic vial TrayLoaders,  
plastic vial trays and custom made  
stainless steel products.



**HURST CORPORATION 610-687-2404**

Box 737 - Devon, Pennsylvania 19333 - USA

**EI ASSOCIATES**



ARCHITECTURE  
ENGINEERING  
CONSTRUCTION

SINGLE SOURCE RESPONSIBILITY

*From Benchtop to Distribution*

*We Understand Your GxP Facilities.*



Research  
API  
Manufacturing  
Finishing  
Support



INTERPEX 2009  
Visit us at  
**Booth #1242**

8 Ridgedale Avenue, Cedar Knolls, NJ 07927 – 973-775-7777

Contact: [guy\\_cipriano@eiassociates.com](mailto:guy_cipriano@eiassociates.com) – ext. 378

# Thank You to our Sponsors

## ISPE Washington Conference

### Platinum Sponsors



### Gold Sponsors



### Lanyard Sponsor



### Onsite Advertising Sponsor



## ISPE Strasbourg Conference

### Host Sponsor



### France Affiliate Networking Event Sponsor



### IP COP Networking Event Sponsors



ACTIVE CHEMICAL .....	65
AES CLEAN TECHNOLOGY .....	7
BUDZAR INDUSTRIES .....	55
CAL-CHEM CORP.....	64
CHEM SHOW .....	39
COMMISSIONING AGENTS .....	9
CRB CONSULTING ENGINEERS .....	3
JIM CRUMPLEY & ASSOCIATES .....	64
EI ASSOCIATES .....	65
ELETTRACQUA.....	11
FARR AIR POLLUTION CONTROL .....	2
FIKE CORP. ....	33
GE WATER & PROCESS TECHNOLOGIES.....	25
GEA PROCESS ENGINEERING .....	31
GEMU GMBH.....	45
HACH COMPANY.....	41
HOWORTH AIR TECHNOLOGY .....	13
HURST CORP. ....	65
IMA ACTIVE.....	47
INTELLIGEN .....	15
INTERPHEX .....	29
MECO .....	17
MURRAY COMPANY .....	27
NNE PHARMAPLAN.....	68
PARSONS .....	5
PHARMACEUTICAL ONLINE .....	51
PLASCORE .....	35
SIEMENS WATER TECHNOLOGIES.....	21

# Publish your work in Pharmaceutical Engineering, the Global Information Source for Pharmaceutical Science and Manufacturing Professionals.

ISPE's recognized industry magazine, *Pharmaceutical Engineering*, is looking for industry case studies demonstrating advanced technologies, manufacturing efficiencies, and solutions to regulatory compliance issues with a global perspective. Articles must be noncommercial in nature, describe new developments or work, and significantly contribute to the body of knowledge relating to pharmaceutical manufacturing, quality management, and technology.

Do you have an idea, innovative solution, unique application, or success story that you want to share with your colleagues in the biopharmaceutical manufacturing industry?

*Pharmaceutical Engineering* is now accepting articles for its 2010 Editorial Calendar.

For further information,  
please visit us on the Web site at  
[www.ISPE.org/PE](http://www.ISPE.org/PE),  
then connect the following links:  
[How to Submit an Article](#),  
and then [Author Guidelines](#).

The Global Information Source for Pharmaceutical Science and Manufacturing Professionals

# PHARMACEUTICAL ENGINEERING

THE OFFICIAL  
MAGAZINE OF  
ISPE



## JANUARY/FEBRUARY 2010

**Theme:** Process Equipment and Systems  
**Manuscripts Due:** 4 September 2009  
**Publishes:** 22 January 2010

## MARCH/APRIL 2010

**Theme:** Facilities  
**Manuscripts Due:** 3 November 2009  
**Publishes:** 22 March 2010

## MAY/JUNE 2010

**Theme:** Biotechnology  
**Manuscripts Due:** 2 January 2010  
**Publishes:** 21 May 2010

## JULY/AUGUST 2010

**Theme:** Quality and Regulatory Issues  
**Manuscripts Due:** 2 March 2010  
**Publishes:** 21 July 2010

## SEPTEMBER/OCTOBER 2010

**Theme:** Maintenance  
**Manuscripts Due:** 3 May 2010  
**Publishes:** 22 Sept 2010

## NOVEMBER/DECEMBER 2010

**Theme:** Product Security  
**Manuscripts Due:** 2 July 2010  
**Publishes:** 22 Nov 2010



# more than engineering

"ASTM E2500 is a critical **opportunity** for our industry. Companies are realising cost reductions of **40%** or more. NNE Pharmaplan is a **thought leader** and unique in its expertise. We would like a chance to **prove** it to you."

We **lead**. We **deliver**.  
We are **more than engineering**.



Consulting



Engineering



Construction



Validation



Solutions

To succeed in today's market, you require a focused partner created from industry DNA who can deliver a competitive advantage.

For more information on our ASTM E2500 know-how, please write to [contact@nnepharmaplan.com](mailto:contact@nnepharmaplan.com)

nne pharmaplan®

[nnepharmaplan.com](http://nnepharmaplan.com)